

Product Specification	No.	S01F50114	Page	1/4
-----------------------	-----	-----------	------	-----

1. Applied Scope

This product specification applies to 67 × 20 × 1.5mm+ 0.2mm black PP synthetic paper

2. Part Name

S01F50114

3. Material

Magnet : EP-7S

4. Material Characteristics

4.1 Material Magnetic Characteristics

Item	SI Units	CGS Units
Residual flux density (Br)	180±15 mT	1800±150 Gs
Coercive force (Hcb)	103.4±16 KA/m	1300±200 Oe
Intrinsic (Hcj)	158±28KA/m	2000±350 Oe
Maximum (BH)max	5.6±0.8 KJ/m ³	0.7±0.1 MGOe

4.2 Material Chemical Characteristics

Item	TEST CONDITIONS	Determined
Hydraulic	At room temperature, 96 hours immersion	excellent
Alcohol	At room temperature, 96 hours immersion	good
A ketone, ethyl ether	At room temperature, 96 hours immersion	bad
Alkalescent	At room temperature, 96 hours immersion	good
Acids	At room temperature, 96 hours immersion	bad

4.3 Material Physical Characteristics

Density	3.70±0.1(g/cm ³)
Hardness	shore (D)=40~65
Bending	Winding in cylindrical fixture does not produce Φ21mm fracture phenomena

4.4 Reliability Test

Item	TEST CONDITIONS	Determined
Weather ability	63 °C, carbon arc lamp irradiation	good
Moisture Resistance	40°C, 90 %RH, 168 hour	excellent
Salt Spray Test	5 % Saline ,96 hour	excellent
Waterproof	65 °C of water, 25 °C saline, 30 minutes, 2 cycles	excellent
Ozone resistance	80ppm, 25°C, 72 hour	Acceptable

5. Magnetization Specification

P = 4.5mm, parallel to the length of magnetization, single-sided multi-polar, B ≥ 580GS

6. Appearance

Confirmed by the limits of a model according to negotiations.

7. Inspection Standard

7.1 Dimensions

Item	Specification	Instrument	Method
Length	67 ⁺³ ₋₁ mm	Caliper	AQL=1.5 MIL-STD-105E- II
Width	20 ⁺³ ₋₁ mm		
Thickness	1.5 ^{+0.1} _{-0.1} mm		

7.2 Material Magnetic Properties

Item	SI Units	CGS Units
Magnetic beam density (B)	≥51mT	≥510Gs
Adsorbability		

Product Specification	No.	S01F50114	Page	3/4
-----------------------	-----	-----------	------	-----

Determine standard : C=0

7.3 Curve

- 1) Winding in cylindrical fixture does not produce $\Phi 21$ mm fracture phenomena.
- 2) Determine standard : C=0

7.4 Appearance

Test methods: visual, AQL=1.5 MIL-STD-105E- II

8. Inspection Record

" Inspection reports," With the goods counterparts.

9. Keeping Method

To prevent rain and sunlight

10. Other

10.1 Move to take light-light.

10.2 Specification changes to be mutual consultation, agreed.

Product Specification	No.	S01F50114	Page	4/4
-----------------------	-----	-----------	------	-----

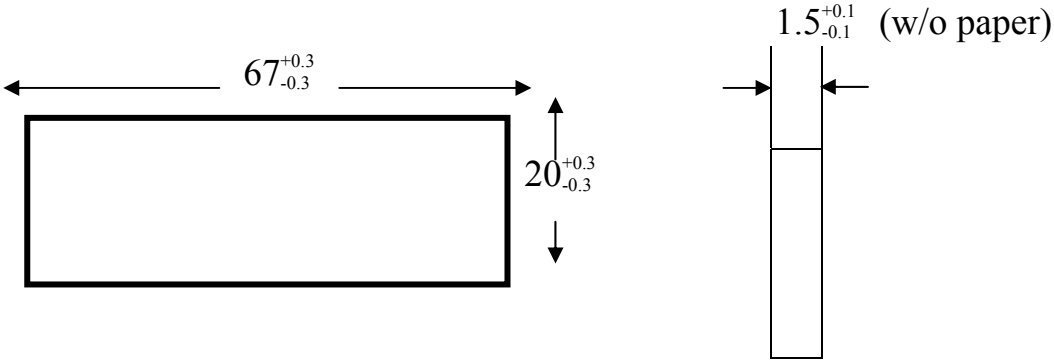

1