

## Transport Castors with Plate, PU Bandage

### Swivel Castors

**Material:** Fork: steel plate, zinc-plated.  
Tread: Prothane®, cast polyurethane 95 +/-3° Shore A.

Wheel body: aluminium, screwed.

Wheel mounting: ball bearing.

Swivel bearing: double ball wreath.

For indoor and outdoor use. Suitable for high loads. Non-marking and abrasion resistant. Good resistance to oil, grease, petrol and chemicals.

**Temperature range:** -20°C to +70°C.

Ordering Details: e.g.: Product No. 777 610 80,  
Swivel castor, PU, D 80 mm

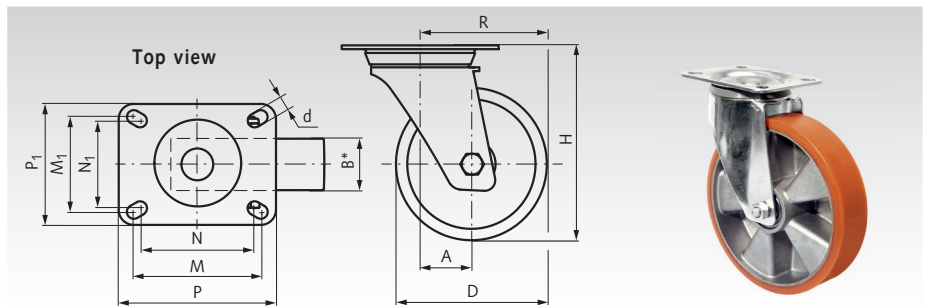

Product No.	D mm	B mm	H mm	A mm	R mm	d mm	P mm	P <sub>1</sub> mm	M mm	M <sub>1</sub> mm	N mm	N <sub>1</sub> mm	Load capacity kg	Weight kg
777 610 80	80	20	105	34	74	9	104	80	84	64	76	56	120	0,55
777 611 00	100	40	132	36	86	9**	105	85	80	60	-	-	200	1,40
777 611 25	125	38	157	36	98,5	9**	105	85	80	60	-	-	300	1,60
777 611 50	150	40	181	58	133	12	135	110	105	80	100	75	250	2,10
777 611 60	160	50	195	58	138	12	135	110	105	80	100	75	300	2,38
777 612 00	200	50	235	58	158	12	135	110	105	80	100	75	300	2,75

### Swivel Castors with Brake

**Material:** Fork: steel plate, zinc-plated.  
Tread: Prothane®, cast polyurethane 95 +/-3° Shore A.

Wheel body: aluminium, screwed.

Wheel mounting: ball bearing.

Swivel bearing: double ball wreath.

For indoor and outdoor use. Suitable for high loads. Non-marking and abrasion resistant. Good resistance to oil, grease, petrol and chemicals.

**Temperature range:** -20°C to +70°C.

Ordering Details: e.g.: Product No. 777 620 80,  
Swivel castor with brake, PU, D 80 mm

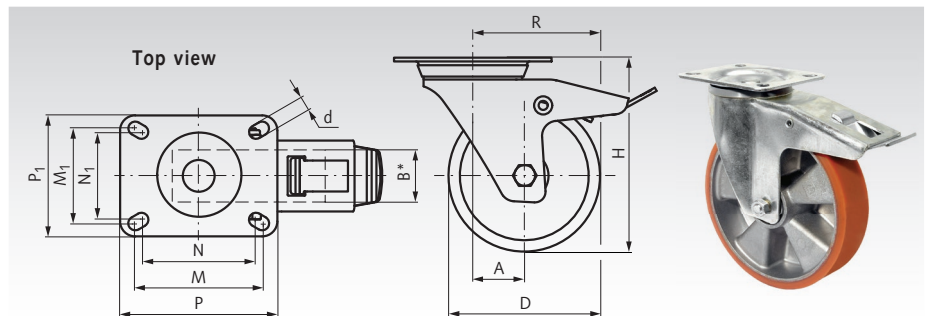

Product No.	D mm	B mm	H mm	A mm	R mm	d mm	P mm	P <sub>1</sub> mm	M mm	M <sub>1</sub> mm	N mm	N <sub>1</sub> mm	Load capacity kg	Weight kg
777 620 80	80	20	105	34	74	9	104	86	84	64	76	56	120	0,82
777 621 00	100	40	132	36	86	9**	105	86	80	60	-	-	200	1,70
777 621 25	125	38	157	36	98,5	9**	105	86	80	60	-	-	300	1,95
777 621 50	150	40	181	58	133	12	135	110	105	80	100	75	250	2,52
777 621 60	160	50	195	58	138	12	135	110	105	80	100	75	300	2,90
777 622 00	200	50	235	58	158	12	135	110	105	80	100	75	300	3,40

### Fixed Castors

**Material:** Fork: steel plate, zinc-plated.  
Tread: Prothane®, cast polyurethane 95 +/-3° Shore A.

Wheel body: aluminium, screwed.

Wheel mounting: ball bearing.

For indoor and outdoor use. Suitable for high loads. Non-marking and abrasion resistant. Good resistance to oil, grease, petrol and chemicals.

**Temperature range:** -20°C to +70°C.

Ordering Details: e.g.: Product No. 777 630 80,  
Fixed castor, PU, D 80 mm

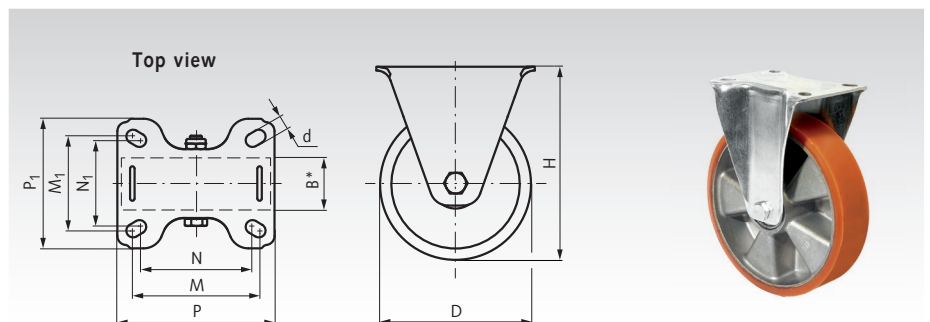

Product No.	D mm	B mm	H mm	d mm	P mm	P <sub>1</sub> mm	M mm	M <sub>1</sub> mm	N mm	N <sub>1</sub> mm	Load capacity kg	Weight kg
777 630 80	80	20	105	9	104	86	84	64	76	56	120	0,45
777 631 00	100	40	132	9**	105	86	80	60	-	-	200	1,10
777 631 25	125	38	157	9**	105	86	80	60	-	-	300	1,45
777 631 50	150	40	181	12	135	110	105	80	100	75	250	1,75
777 631 60	160	50	195	12	135	110	105	80	100	75	300	1,80
777 632 00	200	50	235	12	135	110	105	80	100	75	300	2,10

\* Width of wheel. \*\* No long hole, bore with Ø d.