

SL1021A/B Series

Gas Discharge Tubes



Description

GDT circuit protection devices dissipate electrical surge energy safely within a contained plasma gas. Commonly used to help protect sensitive telecom and networking equipment and lines, GDTs protect from damage that may result from lightning strikes and equipment switching operations.

The Littelfuse GDT series described in this document are available in a variety of leaded and surface mount forms and offered with and without optional fail-safe clip. Please refer to the electrical specifications, dimension and packaging options section of this document for additional information.

SL1021A/B Series:

SL1021A/B series GDTs are designed to offer high levels of performance on fast rising transients in the range of 100V/μS to 1KV/μS, which are those most likely created by induced lightning disturbances.

These devices feature ultra low capacitance (typically 1.5pF or less) and are extremely robust with SL1021A devices able to divert a 10,000 Amp pulse without destruction, and SL1021B suffix devices able to divert a 20,000 Amp pulse without destruction.

These series offer optimized internal geometry which provide low insertion loss at high frequencies, ideal for the protection of broadband and other high speed transmission equipment.

Additional Information



Resources
SL1021A



Accessories
SL1021A



Samples
SL1021A



Resources
SL1021B



Accessories
SL1021B



Samples
SL1021B

Agency Approvals

Agency	Agency File Number
	E128662

3 Electrode GDT Graphical Symbol

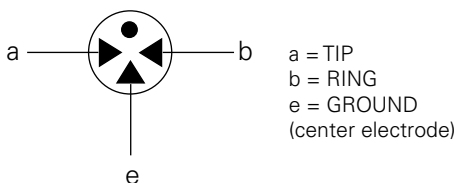

Features

- RoHS compliant
- Low insertion loss
- Excellent response to fast rising transients
- Ultra low capacitance
- 10KA (A suffix devices) / 20KA (B suffix devices) surge capability tested with 8/20μs pulse as defined by IEC 61000-4-5
- Available with thermal failsafe option (add 'F' suffix to part number)

Applications

SL1021:

- Broadband equipment
- ADSL equipment
- XDSL equipment
- Satellite and CATV equipment
- Splitters

- General telecom equipment
- Telecom network interfaces
- Telephone line cards
- Repeaters
- Modems
- Line test equipment

SL1021A/B Series

Gas Discharge Tubes

Product Characteristics

Materials	Dull Tin Plate 17.5 ± 12.5 Microns. with ceramic insulator
Product Marking	'LF' mark, voltage & date code: SL1021A - Red /White text SL1021B - Blue /White text
Glow to arc transition current	~ 1Amp
Glow Voltage	~60-200 Volts
Storage and Operation Temperature	-40 to +90°C
Transverse Voltage (Delay Time)	< 0.2µSec (Tested to ITU-T Rec. K.12)
Arc Voltage	~10 to 35 Volts
Holdover Voltage	<150mS (Tested to ITU-T Rec. K.12)

Electrical Characteristics

Part Number	Device Specifications (at 25°C)						Life Ratings					
	DC Voltage 100V/Sec.			DC Voltage 100 V/µSec.	DC Voltage 1kV/µSec.	Capacitance (@1Mhz)	Insulation Resistance MIN	AC Current 50Hz 1Sec. x10 ¹	Surge Current 8/20µSec x10 ¹	Max Single Surge 8/20µSec ¹	Max Single Surge 10/350µSec ¹	Surge Life 10/1000 µSecx300 ¹
	MIN	TYP	MAX									
SL1021B075	60	75	90	500	650	<1.5pF	>10 ¹⁰ Ω (at 50V)	10Amps	10kA ² 20kA ³	15kA ² 25kA ³	2.5kA ² 5kA ³	200Amps
SL1021A090	72	90	108		600							
SL1021B090	72	90	108									
SL1021A145	116	145	174		600							
SL1021B145	116	145	174									
SL1021A150	120	150	180		850							
SL1021B150	120	150	180									
SL1021A200	150	200	250		950							
SL1021A230	184	230	276									
SL1021B230	184	230	276		1100							
SL1021A250	200	250	300	1200								
SL1021B250	200	250	300									
SL1021A260	210	260	310									
SL1021B260	210	260	310									
SL1021A300	240	300	360									
SL1021B300	240	300	360									
SL1021A350	280	350	420									
SL1021B350	280	350	420									
SL1021A400	320	400	480									
SL1021B400	320	400	480									
SL1021A420	345	420	500									
SL1021B420	345	420	500									
SL1021A450	360	450	540									
SL1021B450	360	450	540									
SL1021A500	400	500	600									
SL1021B500	400	500	600									
SL1021A600	480	600	720									
SL1021B600	480	600	720									

Notes:

- Total current through centre electrode, tested in accordance with ITU-T Rec. K.12
- SL1021A series
- SL1021B series

SL1021A/B Series

Gas Discharge Tubes

Time vs. Current for Failsafe

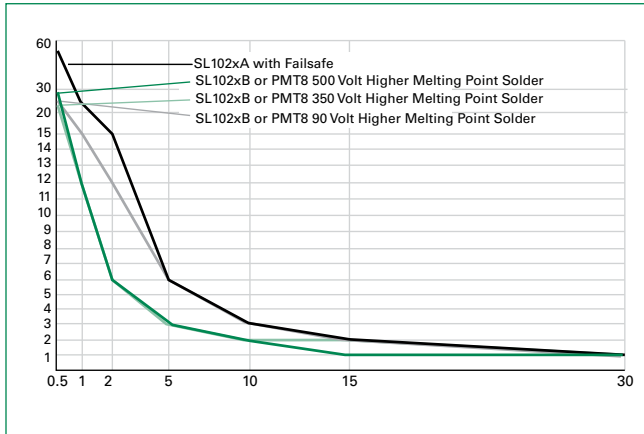

Voltage vs. Time Characteristic

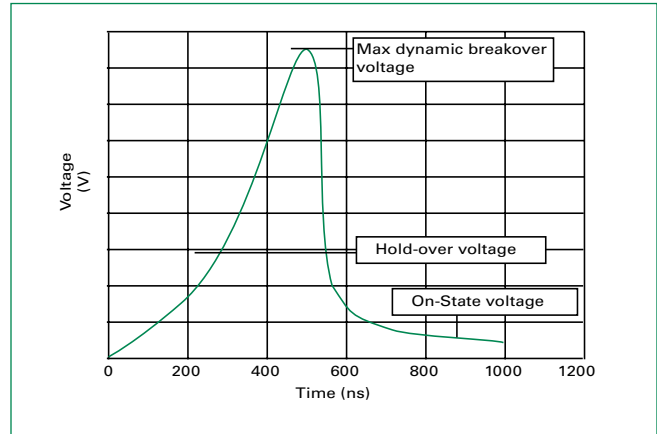

Soldering Parameters - Reflow Soldering (Surface Mount Devices)

Reflow Condition	Pb – Free assembly	
Pre Heat	- Temperature Min ($T_{s(min)}$)	150°C
	- Temperature Max ($T_{s(max)}$)	200°C
	- Time (Min to Max) (t_p)	60 – 180 secs
Average ramp up rate (Liquidus Temp (T_L) to peak)	3°C/second max	
$T_{s(max)}$ to T_L - Ramp-up Rate	5°C/second max	
Reflow	- Temperature (T_L) (Liquidus)	217°C
	- Temperature (t_L)	60 – 150 seconds
Peak Temperature (T_p)	260 ^{+0/-5} °C	
Time within 5°C of actual peak Temperature (t_p)	10 – 30 seconds	
Ramp-down Rate	6°C/second max	
Time 25°C to peak Temperature (T_p)	8 minutes Max.	
Do not exceed	260°C	

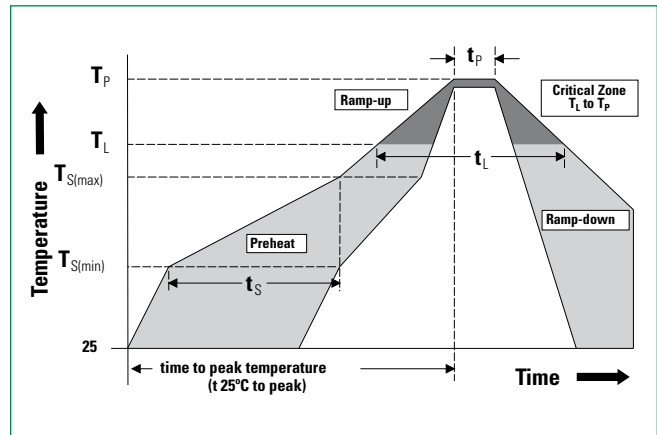

Soldering Parameters - Hand Soldering

Solder Iron Temperature: 350° C +/- 5°C
 Heating Time: 5 seconds max.

Soldering Parameters - Wave Soldering (Thru-Hole Devices)

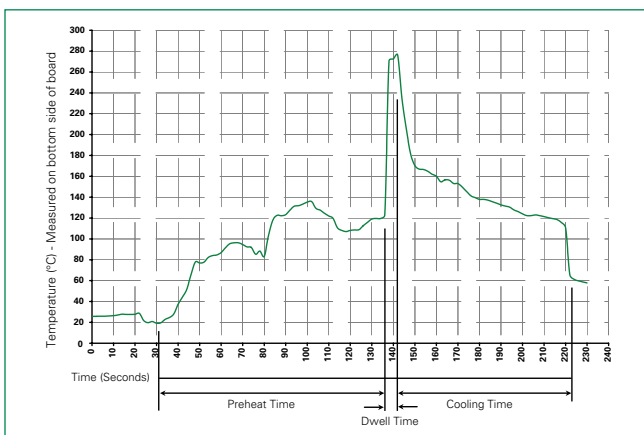

Recommended Process Parameters:

Wave Parameter	Lead-Free Recommendation
Preheat: (Depends on Flux Activation Temperature)	(Typical Industry Recommendation)
Temperature Minimum:	100° C
Temperature Maximum:	150° C
Preheat Time:	60-180 seconds
Solder Pot Temperature:	280° C Maximum
Solder Dwell Time:	2-5 seconds

Note: Surge Arrestors with a Failsafe mechanism should be individually examined after soldering

SL1021A/B Series

Gas Discharge Tubes

Device Dimensions

Note: Failsafe option dimensions shown in green.

Shaped Radial Ledged Devices:

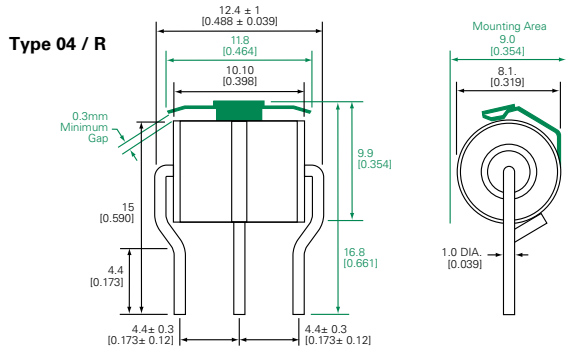

Core Devices:

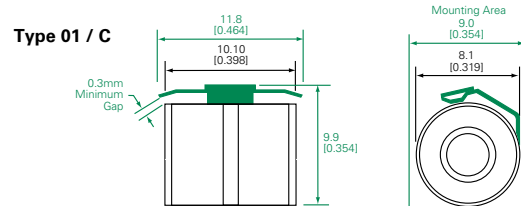

Straight Radial Ledged Devices:

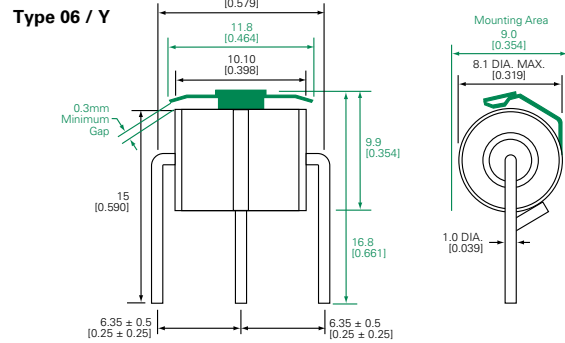
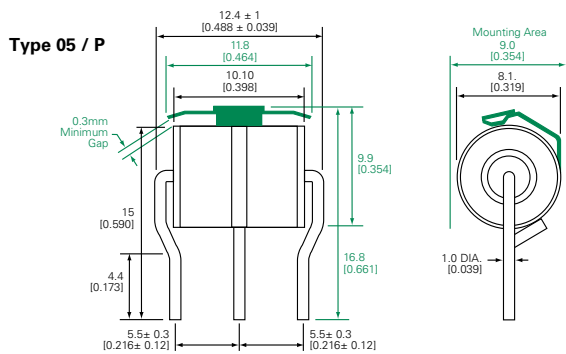

Straight "T" Ledged Devices:

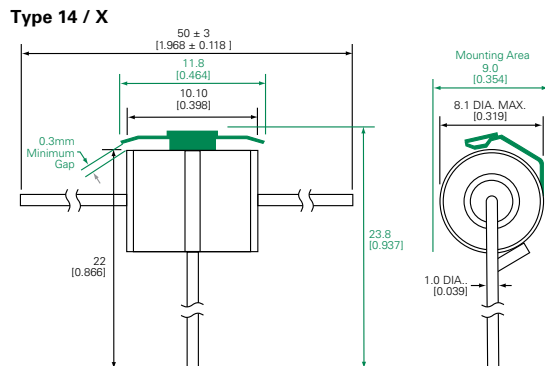

SL1021A/B Series

Gas Discharge Tubes

Part Numbering System and Ordering Information

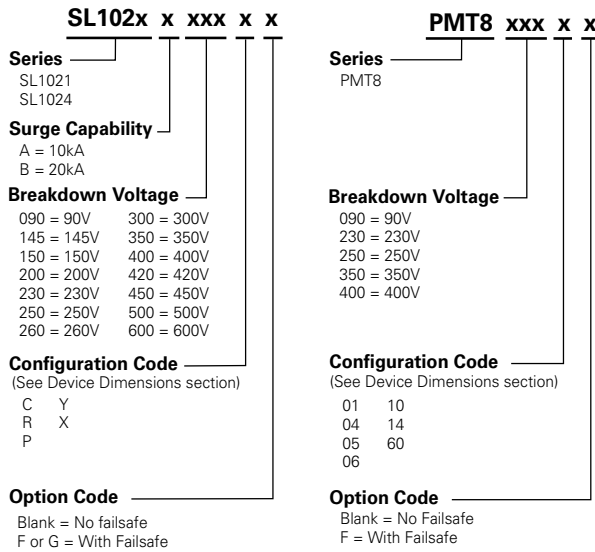

Packaging

For 'SL1021A/B' device type C, R, P, Y packing

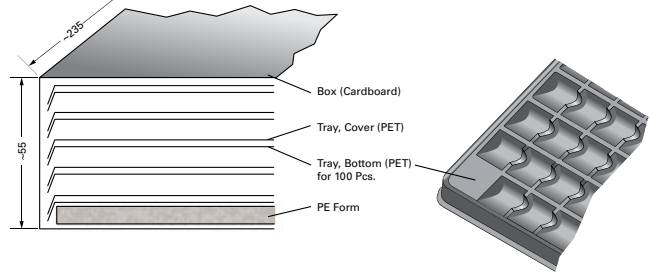

For 'SL1021A/B' device type X packing

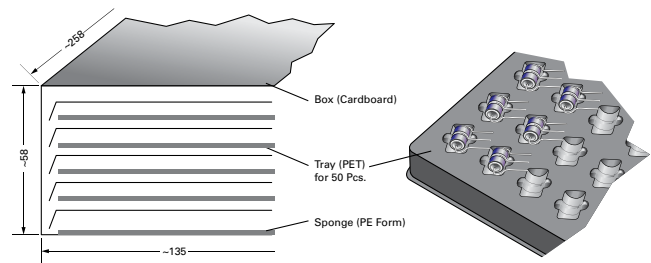

Device Type	Description	Quantity
Type C	100pcs/tray x 5 trays per carton	500
Type R	100pcs/tray x 5 trays per carton	500
Type P	100pcs/tray x 5 trays per carton	500
Type Y	100pcs/tray x 5 trays per carton	500
Type X	50pcs/tray x 5 trays per carton	250

* Please contact the factory for further packaging information.

Disclaimer Notice - Information furnished is believed to be accurate and reliable. However, users should independently evaluate the suitability of and test each product selected for their own applications. Littelfuse products are not designed for, and may not be used in, all applications. Read complete Disclaimer Notice at: www.littelfuse.com/disclaimer-electronics.