

Features

- 1-channel isolated barrier
- 24 V DC supply (Power Rail)
- Input for approved dry contacts or SN/S1N sensors
- Relay output
- Fault indication output
- Line fault detection (LFD)
- Up to SIL3 acc. to IEC 61508
- Up to PL d acc. to EN ISO 13849

Function

This isolated barrier is used for intrinsic safety applications. The device transfers digital signals (SN/S1N proximity sensors or approved dry contacts) from a hazardous area to a safe area.

The input controls one relay contact output with 3 NO contacts (one output is in series to the both output relays for the safety function), one relay contact output with one NO contact, and one passive transistor output.

Unlike an SN/S1N series proximity sensor, a mechanical contact, requires a 10 kΩ resistor to be placed across the contact in addition to a 1.5 kΩ resistor in series.

Lead breakage (LB) and short circuit (SC) conditions of the control circuit are continuously monitored.

During an fault condition, the fault indication output energizes and outputs I and II de-energize.

For safety applications up to SIL3, output I must be used. For safety applications up to SIL2, output I and output II can be used.

Assembly

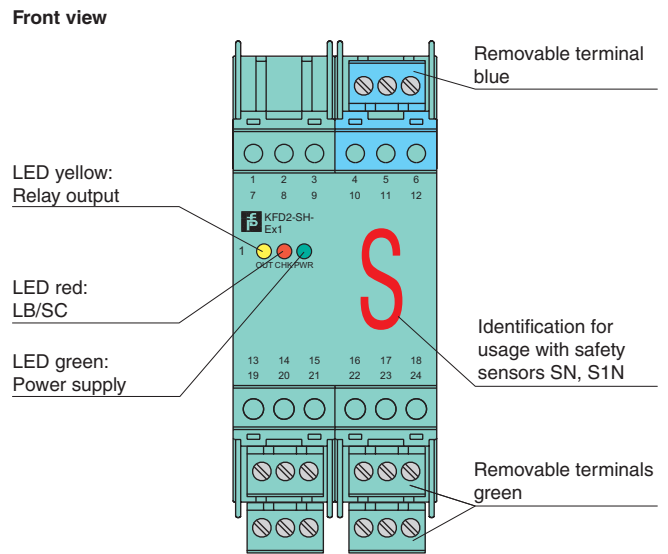

Connection

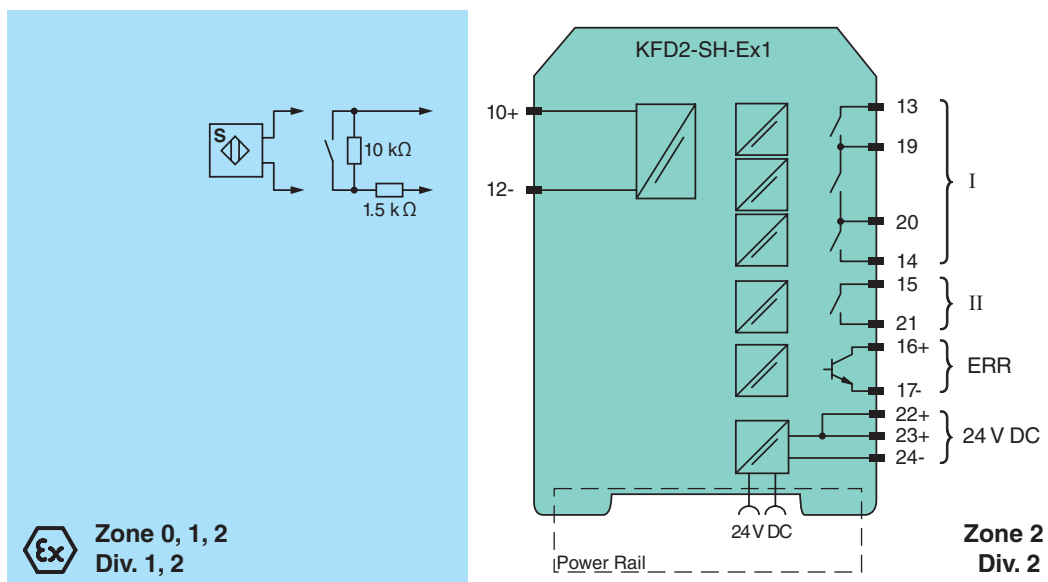

Release date 2013-12-18 16:38 Date of issue 2013-12-18 046903_eng.xml

Refer to "General Notes Relating to Pepperl+Fuchs Product Information".

General specifications		
Signal type		Digital Input
Functional safety related parameters		
Safety Integrity Level (SIL)		SIL 3
Supply		
Connection		Power Rail or terminals 22+, 23+, 24-
Rated voltage		20 ... 35 V DC
Ripple		≤ 10 %
Rated current		≤ 130 mA
Power loss		2.1 W
Power consumption		≤ 2.3 W
Input		
Connection		terminals 10+, 12-
Open circuit voltage/short-circuit current		approx. 8.4 V DC / approx. 11.7 mA
Lead resistance		≤ 50 Ω, in hazardous area cable capacitances and inductivities are to be taken into account
Switching point		
Relay de-energized		I < 2.1 mA and I > 5.9 mA
Relay energized		2.8 mA < I < 5.3 mA
Response delay		≤ 1 ms
Output		
Connection		output I: terminals 13, 14 ; output II: terminals 15, 21 ; output III: terminals 16+, 17-
Output I		relay , signal
Contact loading		50 V AC/1 A/cos φ > 0.7; 24 V DC/1 A resistive load
Mechanical life		50 x 10 ⁶ switching cycles
Output II		relay , signal
Contact loading		50 V AC/1 A/cos φ > 0.7; 24 V DC/1 A resistive load
Mechanical life		50 x 10 ⁶ switching cycles
Output III		electronic output, passive , fault signal
Rated voltage		10 ... 30 V DC
Signal level		1-signal: (L+) -2.5 V (7 mA, short-circuit proof) / 0-signal: blocked output (Leakage current ≤ 10 mA)
Transfer characteristics		
Switching frequency		5 Hz
Electrical isolation		
Output/power supply		reinforced insulation according to IEC/EN 61010-1, rated insulation voltage 300 V _{eff}
Mutual output I, II, III		basic insulation according to IEC/EN 61010-1, rated insulation voltage 50 V _{eff}
Directive conformity		
Electromagnetic compatibility		
Directive 2004/108/EC		EN 61326-1:2006
Low voltage		
Directive 2006/95/EC		EN 61010-1:2010
Conformity		
Electromagnetic compatibility		NE 21:2011
Protection degree		IEC 60529:2001
Safety		IEC 61508:2000
Ambient conditions		
Ambient temperature		-20 ... 60 °C (-4 ... 140 °F)
Mechanical specifications		
Protection degree		IP20
Mass		approx. 280 g
Dimensions		40 x 107 x 115 mm (1.6 x 4.2 x 4.5 in) , housing type C1
Mounting		on 35 mm DIN mounting rail acc. to EN 60715:2001
Data for application in connection with Ex-areas		
EC-Type Examination Certificate		PTB 00 ATEX 2042 , for additional certificates see www.pepperl-fuchs.com
Group, category, type of protection		Ⓔ II (1)GD [EEx ia] IIC [circuit(s) in zone 0/1/2]
Input		EEx ia IIC
Voltage	U _o	9.56 V
Current	I _o	16.8 mA
Power	P _o	41 mW (linear characteristic)
Supply		
Maximum safe voltage	U _m	40 V AC/DC (Attention! The rated voltage can be lower.)
Output		
Maximum safe voltage	U _m	output I/output II: 253 V AC/DC (Attention! U _m is no rated voltage.) output III: 60 V AC/DC (Attention! U _m is no rated voltage.)

Release date 2013-12-18 16:38 Date of issue 2013-12-18 046903_eng.xml

Refer to "General Notes Relating to Pepperl+Fuchs Product Information".

Pepperl+Fuchs Group
www.pepperl-fuchs.com

USA: +1 330 486 0002
pa-info@us.pepperl-fuchs.com

Germany: +49 621 776 2222
pa-info@de.pepperl-fuchs.com

Singapore: +65 6779 9091
pa-info@sg.pepperl-fuchs.com

Statement of conformity	TÜV 99 ATEX 1493 X , observe statement of conformity
Group, category, type of protection, temperature class	⊕ II 3G Ex nA nC IIC T4
Electrical isolation	
Input/Output	safe electrical isolation acc. to IEC/EN 60079-11, voltage peak value 375 V
Input/power supply	safe electrical isolation acc. to IEC/EN 60079-11, voltage peak value 375 V
Directive conformity	
Directive 94/9/EC	EN 60079-0:2012 , EN 60079-11:2007 , EN 60079-15:2010 , EN 61241-11:2006
International approvals	
FM approval	
Control drawing	116-0158
General information	
Supplementary information	EC-Type Examination Certificate, Statement of Conformity, Declaration of Conformity, Attestation of Conformity and instructions have to be observed where applicable. For information see www.pepperl-fuchs.com .

Function

The input (terminals 10, 12) may generally be operated only with **potentially free** (passive) switches.

Single channel operations up to SIL3 **must** occur via terminals 13 and 14. The center tap of the contacts (terminals 19, 20) can **also** be used if an operation is to occur a redundant branch.

If the device is used for safety operations the information in the test documents should be observed. The output III error message delivers a "1"-signal when the control circuit experiences lead breakage (LB) or a short circuit (LK).

The device has removable terminals.

Maximal switching power of the output

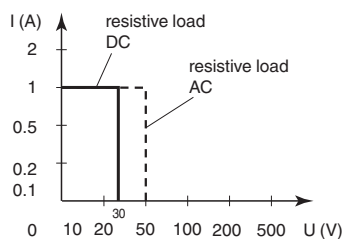

Accessories

Power feed module KFD2-EB2

The power feed module is used to supply the devices with 24 V DC via the Power Rail. The fuse-protected power feed module can supply up to 150 individual devices depending on the power consumption of the devices. A galvanically isolated mechanical contact uses the Power Rail to transmit collective error messages.

Power Rail UPR-03

The Power Rail UPR-03 is a complete unit consisting of the electrical inset and an aluminium profile rail 35 mm x 15 mm. To make electrical contact, the devices are simply engaged.

Profile Rail K-DUCT with Power Rail

The profile rail K-DUCT is an aluminum profile rail with Power Rail insert and two integral cable ducts for system and field cables. Due to this assembly no additional cable guides are necessary.



Power Rail and Profile Rail must not be fed via the device terminals of the individual devices!

Release date 2013-12-18 16:38 Date of issue 2013-12-18 046903_eng.xml