

**Description:** Bluetooth, WiFi Antenna

**Series:** The Blue Dot

**PART NUMBER:** W3092



### Features:

- Chip Antenna
- Frequency:  
2400MHz ~ 2483MHz
- Low profile  
2.0mm(Length) x 1.2mm(Width)  
x 0.55mm(Thickness)

### Applications:

- WLAN
- 802.11b/g
- Bluetooth
- Zigbee, ISM 2.4GHz

All dimensions are in mm / inches

Issue: 1639

In the effort to improve our products, we reserve the right to make changes judged to be necessary.

CONFIDENTIAL AND PROPRIETARY INFORMATION

This document contains confidential and proprietary information of Pulse Electronics, Inc. (Pulse) and is protected by copyright, trade secret and other state and federal laws. Its receipt or possession does not convey any rights to reproduce, disclose its contents, or to manufacture, use or sell anything it may describe. Reproduction, disclosure or use without specific written authorization of Pulse is strictly forbidden.

For more information:

Pulse Worldwide Headquarters  
12220 World Trade Drive  
San Diego, CA 92128  
USA  
Tel: 1-858-674-8100

Pulse/Larsen Antennas  
18110 SE 34<sup>th</sup> St Bldg 2 Suite 250  
Vancouver, WA 98683  
USA  
Tel: 1-360-944-7551

Europe Headquarters  
Pulse GmbH & Do, KG  
Zeppelinstrasse 15  
Herrenberg, Germany  
Tel: 49 7032 7806 0

Pulse (Suzhou) Wireless Products Co, Inc.  
99 Huo Ju Road(#29 Bldg, 4<sup>th</sup> Phase  
Suzhou New District  
Jiangsu Province, Suzhou 215009 PR China  
Tel: 86 512 6807 9998



**Description:** Bluetooth, WiFi Antenna**Series:** The Blue Dot**PART NUMBER:** W3092**ELECTRICAL SPECIFICATIONS**

Frequency	2400-2483	MHz
Nominal Impedance	50	$\Omega$
VSWR	3	max
Gain (Typ.)	0.89	dBi
Efficiency(Typ.)	50	%
Polarization	Linear	

Issue: 1639

In the effort to improve our products, we reserve the right to make changes judged to be necessary.

CONFIDENTIAL AND PROPRIETARY INFORMATION

This document contains confidential and proprietary information of Pulse Electronics, Inc. (Pulse) and is protected by copyright, trade secret and other state and federal laws. Its receipt or possession does not convey any rights to reproduce, disclose its contents, or to manufacture, use or sell anything it may describe. Reproduction, disclosure or use without specific written authorization of Pulse is strictly forbidden.

**Description:** Bluetooth, WiFi Antenna

**Series:** The Blue Dot

**PART NUMBER:** W3092

### MECHANICAL SPECIFICATIONS

Weight	0.005 g
Size	2.0x1.2x0.55 mm

### ENVIRONMENTAL SPECIFICATIONS

Operating temperature	-40/+105 ° C
High temperature resistance	150 ° C, 1000 hours
Low temperature resistance	-40 ° C, 1000 hours
Humidity	85%R.H. 85±5 ° C, 1000 cycles
Soldering heat resistance	260 ° C 10s
Thermal shock	-40/+105 ° C
Storage condition	
At warehouse	0-30 ° C, <60%R.H.,shoule be used<1 year
On board	-40 ~85 ° C, <85%R.H

Description: Bluetooth, WiFi Antenna

Series: The Blue Dot

PART NUMBER: W3092

MECHANICAL DRAWING

Pad for SMT process

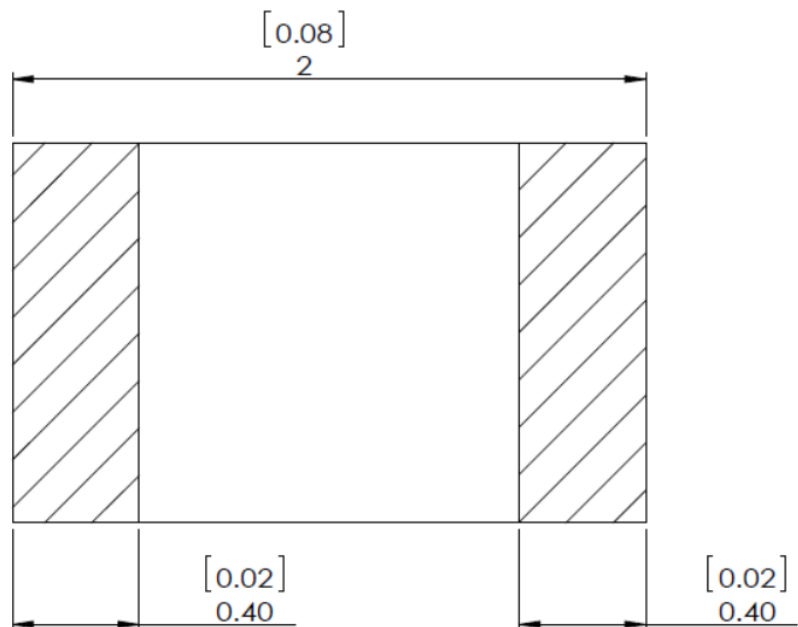
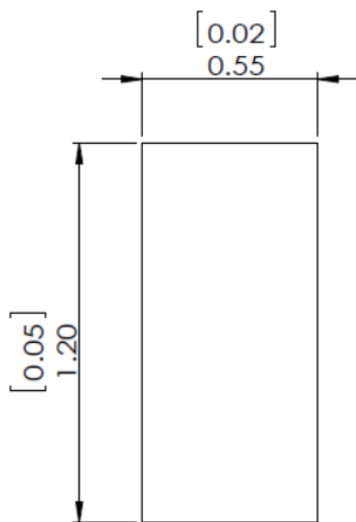
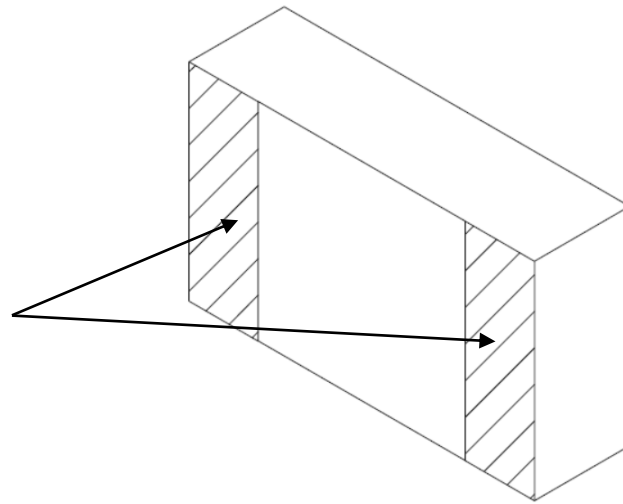

Issue: 1639

In the effort to improve our products, we reserve the right to make changes judged to be necessary.

CONFIDENTIAL AND PROPRIETARY INFORMATION

This document contains confidential and proprietary information of Pulse Electronics, Inc. (Pulse) and is protected by copyright, trade secret and other state and federal laws. Its receipt or possession does not convey any rights to reproduce, disclose its contents, or to manufacture, use or sell anything it may describe. Reproduction, disclosure or use without specific written authorization of Pulse is strictly forbidden.

Description: Bluetooth, WiFi Antenna

Series: The Blue Dot

PART NUMBER: W3092

OTHER SPECIFICATIONS

Recommended PCB layout(Unit:mm)

PCB size(L X W X T): 110 X 55 X 1mm

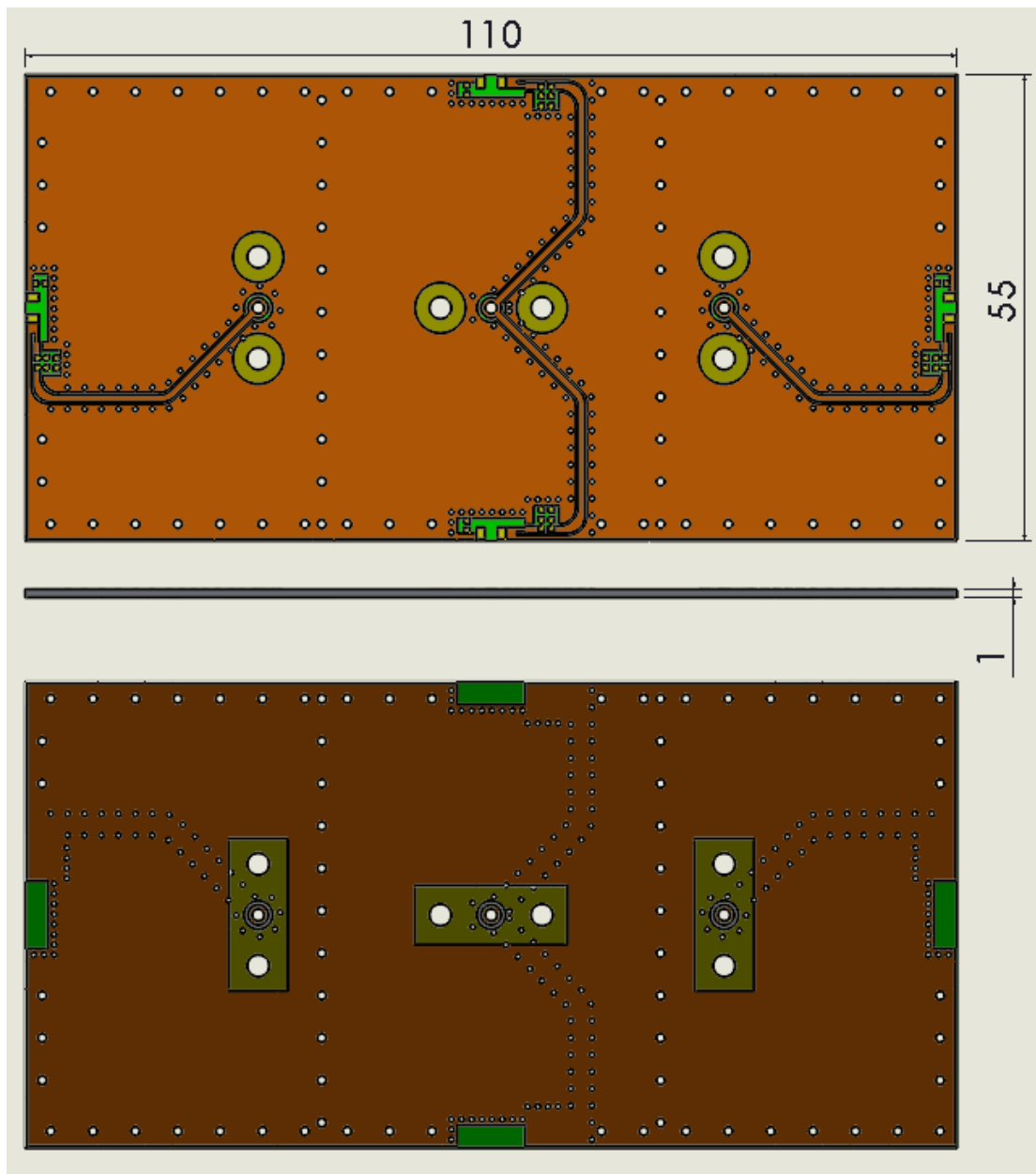

Issue: 1639

In the effort to improve our products, we reserve the right to make changes judged to be necessary.

CONFIDENTIAL AND PROPRIETARY INFORMATION

This document contains confidential and proprietary information of Pulse Electronics, Inc. (Pulse) and is protected by copyright, trade secret and other state and federal laws. Its receipt or possession does not convey any rights to reproduce, disclose its contents, or to manufacture, use or sell anything it may describe. Reproduction, disclosure or use without specific written authorization of Pulse is strictly forbidden.

**Description:** Bluetooth, WiFi Antenna

**Series:** The Blue Dot

**PART NUMBER:** W3092

**OTHER SPECIFICATIONS**

**PCB top side layout**

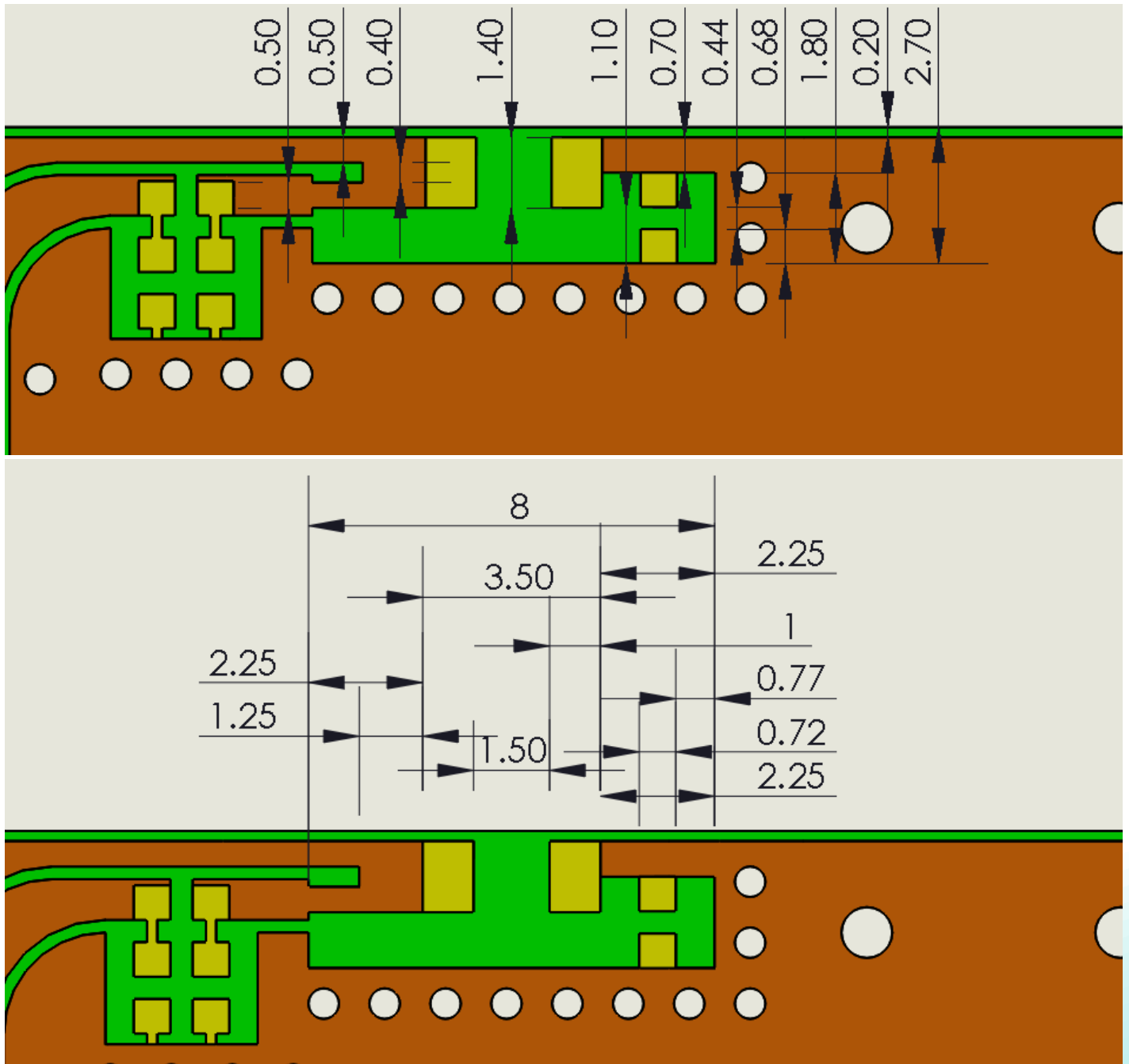

Issue: 1639

In the effort to improve our products, we reserve the right to make changes judged to be necessary.

CONFIDENTIAL AND PROPRIETARY INFORMATION

This document contains confidential and proprietary information of Pulse Electronics, Inc. (Pulse) and is protected by copyright, trade secret and other state and federal laws. Its receipt or possession does not convey any rights to reproduce, disclose its contents, or to manufacture, use or sell anything it may describe. Reproduction, disclosure or use without specific written authorization of Pulse is strictly forbidden.

Description: Bluetooth, WiFi Antenna

Series: The Blue Dot

PART NUMBER: W3092

OTHER SPECIFICATIONS

PCB bottom side layout

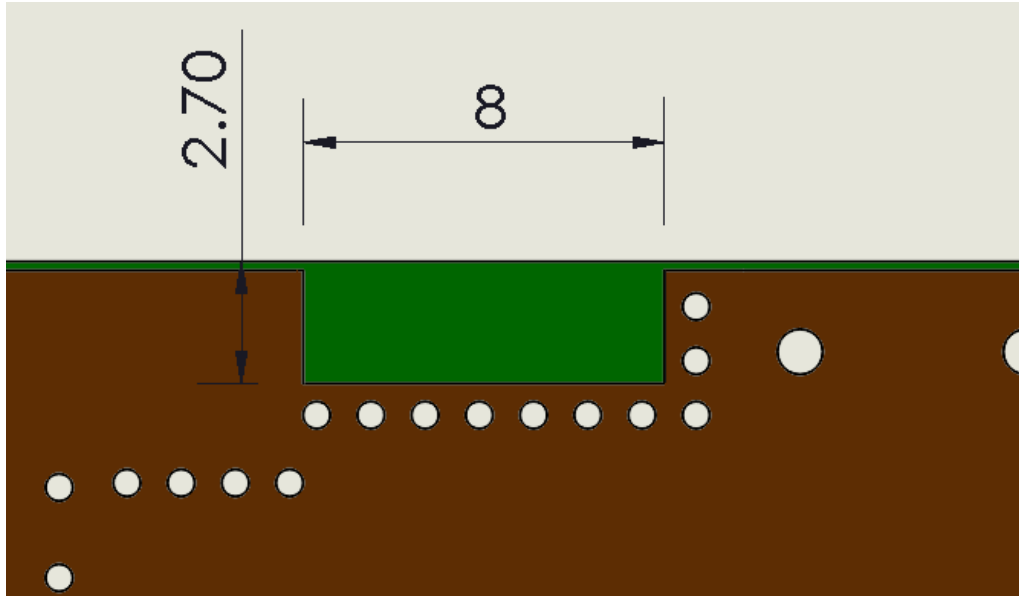

\*Clearance 8mm x 2.7mm : All metallization should be removed from all PCB layers.

Recommended matching circuit

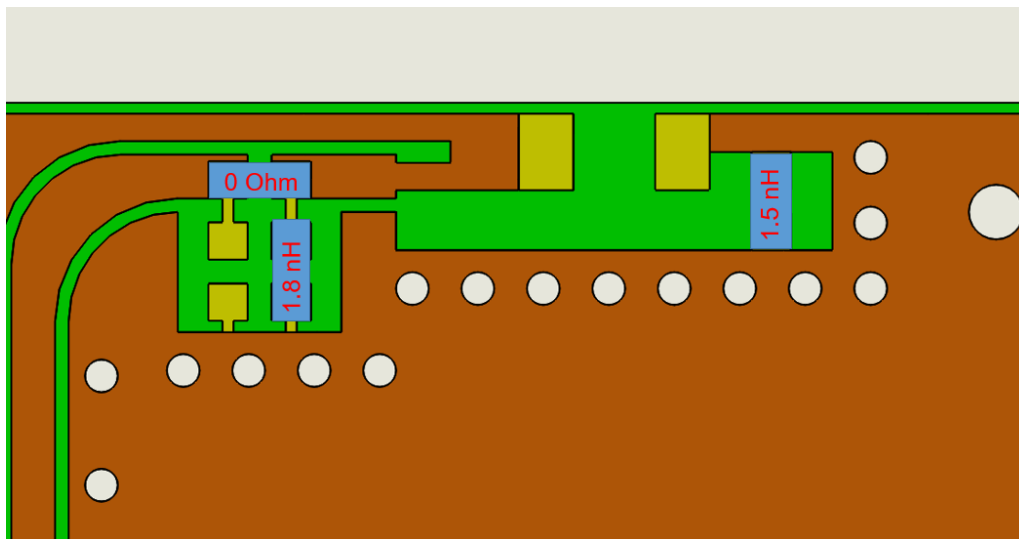

Issue: 1639

In the effort to improve our products, we reserve the right to make changes judged to be necessary.

CONFIDENTIAL AND PROPRIETARY INFORMATION

This document contains confidential and proprietary information of Pulse Electronics, Inc. (Pulse) and is protected by copyright, trade secret and other state and federal laws. Its receipt or possession does not convey any rights to reproduce, disclose its contents, or to manufacture, use or sell anything it may describe. Reproduction, disclosure or use without specific written authorization of Pulse is strictly forbidden.

**Description:** Bluetooth, WiFi Antenna

**Series:** The Blue Dot

**PART NUMBER:** W3092

**OTHER SPECIFICATIONS**

**Recommended reflow soldering**

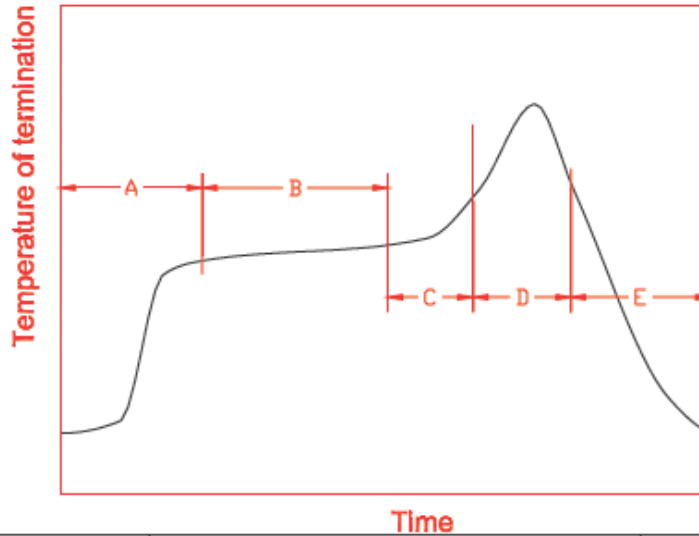

			Time
A	1 <sup>st</sup> rising temperature	The normal to Preheating temperature	30s to 60s
B	Preheating	140°C to 160°C	60s to 120s
C	2 <sup>nd</sup> rising temperature	Preheating to 200°C	20s to 40s
D	Main heating	if 220°C	50s~60s
		if 230°C	40s~50s
		if 240°C	30s~40s
		if 250°C	20s~40s
E	Regular cooling	if 260°C	20s~40s
		200°C to 100°C	1°C/s ~ 4°C/s

\*reference: J-STD-020C

**(1) Soldering gun procedure**

Note the follows, in case of using solder gun for replacement.

(a) The tip temperature must be less than 350°C for the period within 3 seconds by using soldering gun under 30 W.

(b) The soldering gun tip shall not touch this product directly.

**(2) Soldering volume**

Note that excess of soldering volume will easily get crack the body of this product.

Issue: 1639

In the effort to improve our products, we reserve the right to make changes judged to be necessary.

CONFIDENTIAL AND PROPRIETARY INFORMATION

This document contains confidential and proprietary information of Pulse Electronics, Inc. (Pulse) and is protected by copyright, trade secret and other state and federal laws. Its receipt or possession does not convey any rights to reproduce, disclose its contents, or to manufacture, use or sell anything it may describe. Reproduction, disclosure or use without specific written authorization of Pulse is strictly forbidden.



Description: Bluetooth, WiFi Antenna

Series: The Blue Dot

PART NUMBER: W3092

CHARTS

VSWR

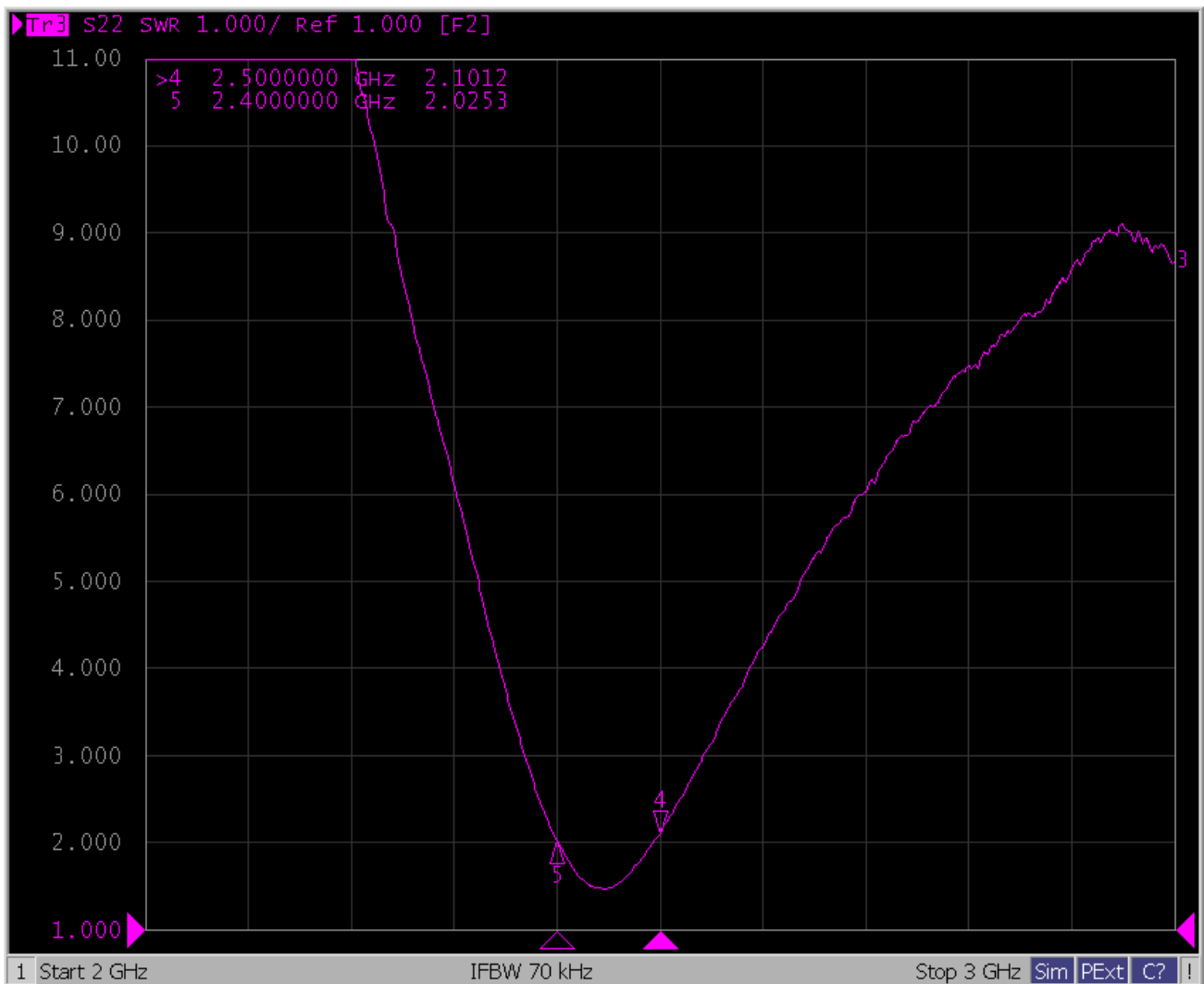

Issue: 1639

In the effort to improve our products, we reserve the right to make changes judged to be necessary.

CONFIDENTIAL AND PROPRIETARY INFORMATION

This document contains confidential and proprietary information of Pulse Electronics, Inc. (Pulse) and is protected by copyright, trade secret and other state and federal laws. Its receipt or possession does not convey any rights to reproduce, disclose its contents, or to manufacture, use or sell anything it may describe. Reproduction, disclosure or use without specific written authorization of Pulse is strictly forbidden.

**Description:** Bluetooth, WiFi Antenna

**Series:** The Blue Dot

**PART NUMBER:** W3092

**CHARTS**

**Efficiency**

Efficiency vs Frequency measured with demo board

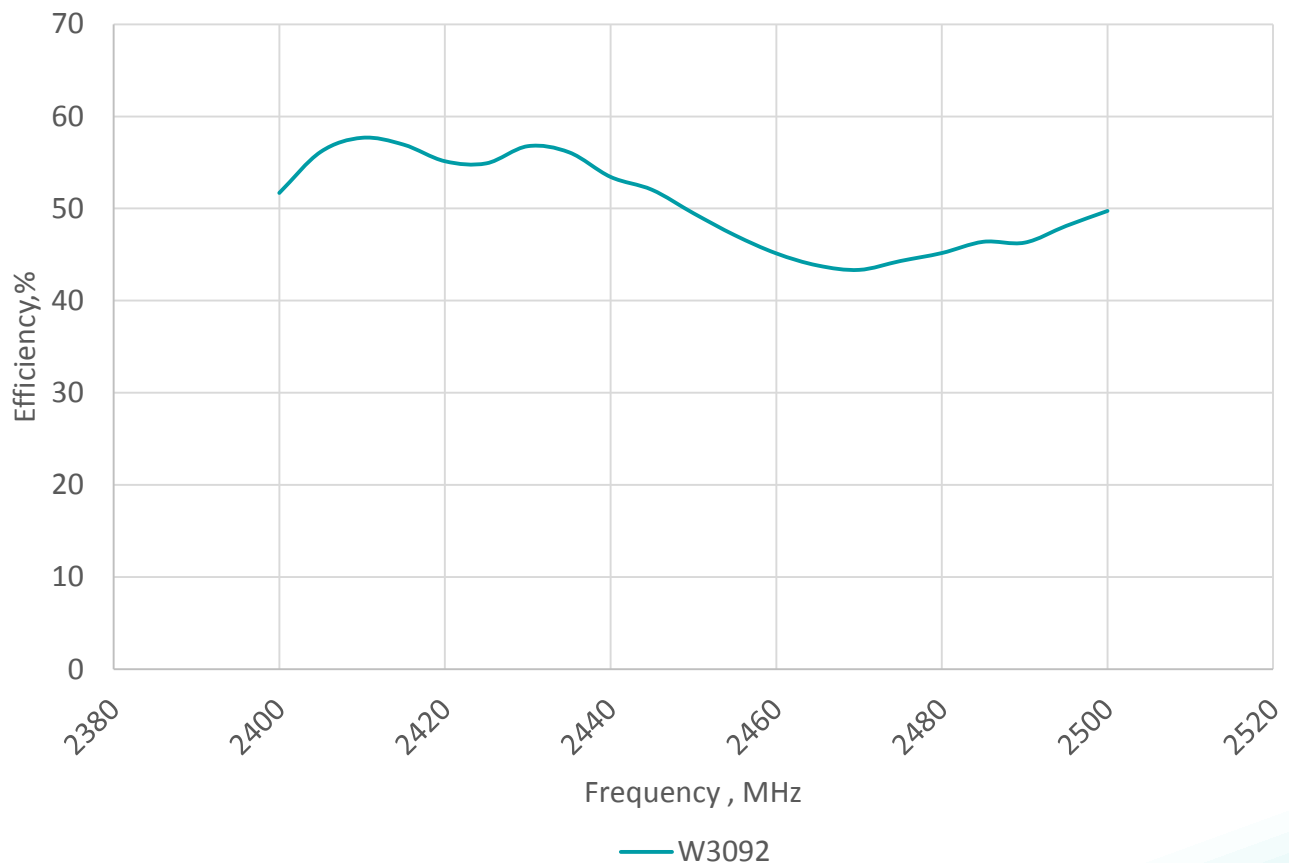

Issue: 1639

In the effort to improve our products, we reserve the right to make changes judged to be necessary.

CONFIDENTIAL AND PROPRIETARY INFORMATION

This document contains confidential and proprietary information of Pulse Electronics, Inc. (Pulse) and is protected by copyright, trade secret and other state and federal laws. Its receipt or possession does not convey any rights to reproduce, disclose its contents, or to manufacture, use or sell anything it may describe. Reproduction, disclosure or use without specific written authorization of Pulse is strictly forbidden.

**Description:** Bluetooth, WiFi Antenna

**Series:** The Blue Dot

**PART NUMBER:** W3092

**CHARTS**

**Peak Gain**

Peak Gain vs Frequency measured with demo board

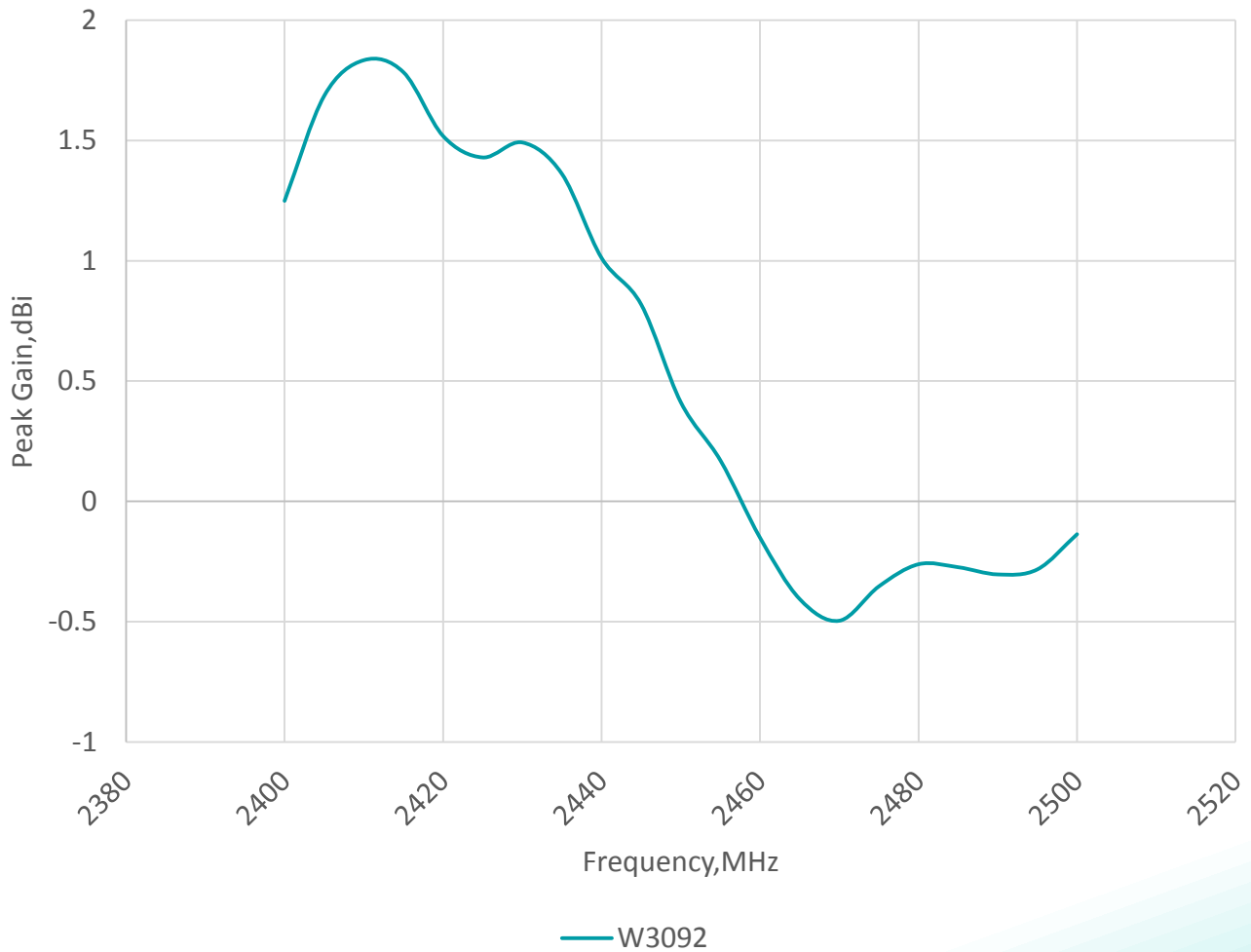

Issue: 1639

In the effort to improve our products, we reserve the right to make changes judged to be necessary.

CONFIDENTIAL AND PROPRIETARY INFORMATION

This document contains confidential and proprietary information of Pulse Electronics, Inc. (Pulse) and is protected by copyright, trade secret and other state and federal laws. Its receipt or possession does not convey any rights to reproduce, disclose its contents, or to manufacture, use or sell anything it may describe. Reproduction, disclosure or use without specific written authorization of Pulse is strictly forbidden.

**Description:** Bluetooth, WiFi Antenna

**Series:** The Blue Dot

**PART NUMBER:** W3092

**CHARTS**

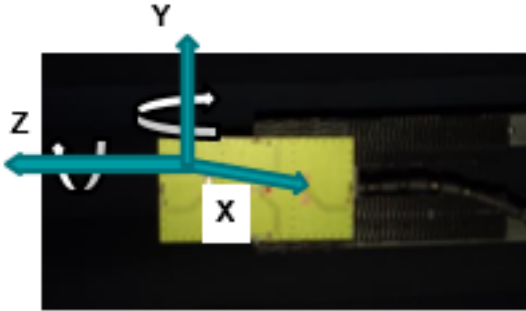

Radiation pattern

XY Plane

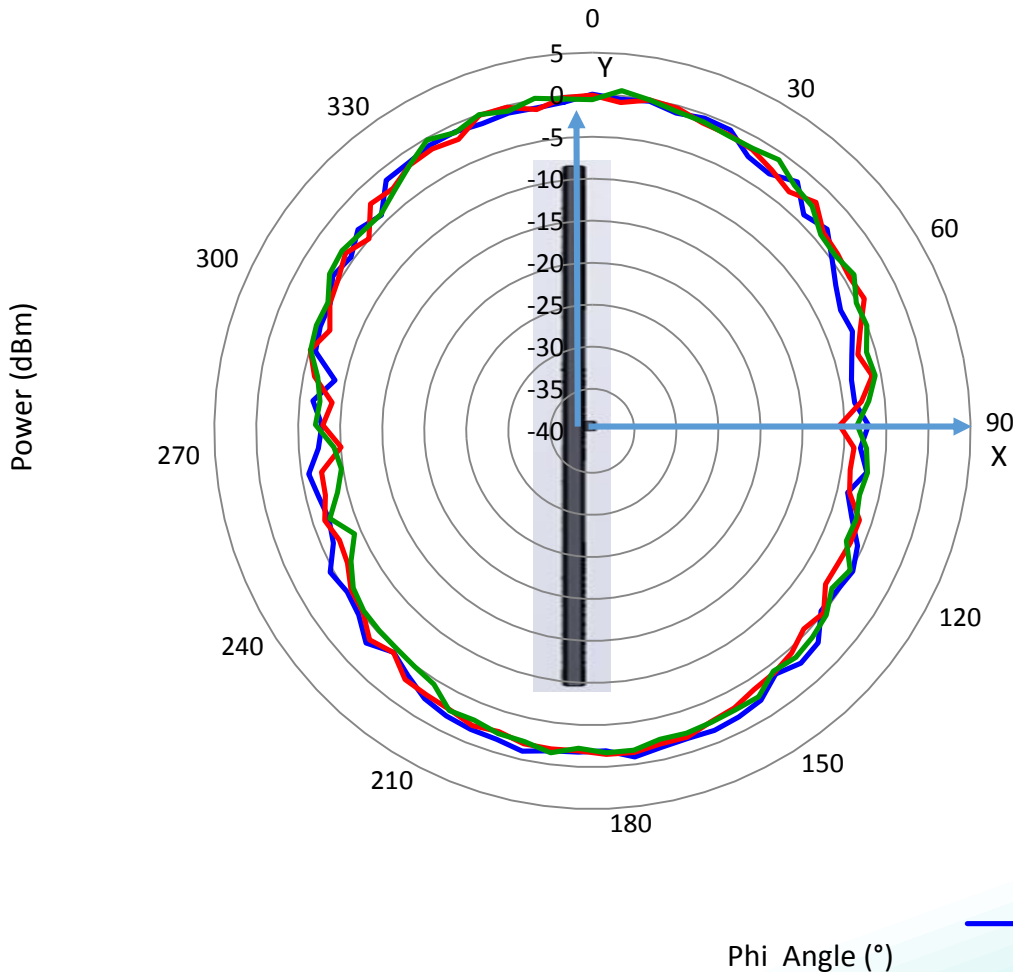

2400MHz	Avg (dBi) = -4.07
	Peak (dBi) = -2.05
	Avg -3 (deg) = 285
2450MHz	Avg (dBi) = -3.89
	Peak (dBi) = -1.39
	Avg -3 (deg) = 265
2480MHz	Avg (dBi) = -3.32
	Peak (dBi) = -1.32
	Avg -3 (deg) = 265

— 2400MHz — 2450MHz — 2500MHz

Issue: 1639

In the effort to improve our products, we reserve the right to make changes judged to be necessary.

CONFIDENTIAL AND PROPRIETARY INFORMATION

This document contains confidential and proprietary information of Pulse Electronics, Inc. (Pulse) and is protected by copyright, trade secret and other state and federal laws. Its receipt or possession does not convey any rights to reproduce, disclose its contents, or to manufacture, use or sell anything it may describe. Reproduction, disclosure or use without specific written authorization of Pulse is strictly forbidden.

Description: Bluetooth, WiFi Antenna

Series: The Blue Dot

PART NUMBER: W3092

CHARTS

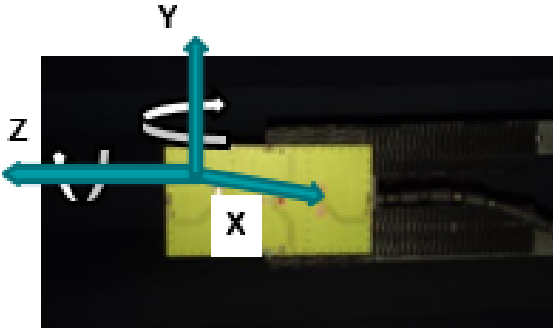

Radiation pattern

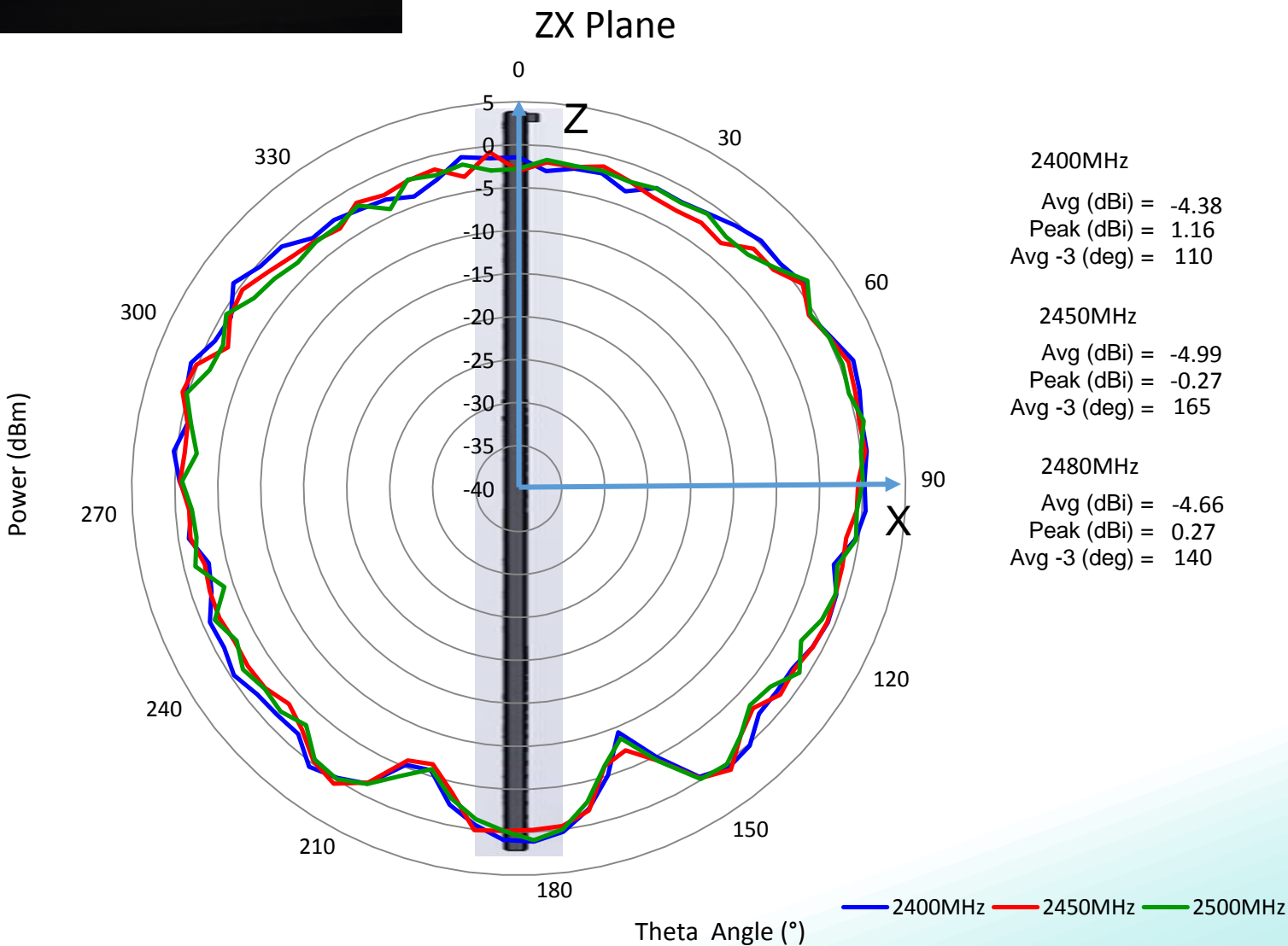

Issue: 1639

In the effort to improve our products, we reserve the right to make changes judged to be necessary.

CONFIDENTIAL AND PROPRIETARY INFORMATION

This document contains confidential and proprietary information of Pulse Electronics, Inc. (Pulse) and is protected by copyright, trade secret and other state and federal laws. Its receipt or possession does not convey any rights to reproduce, disclose its contents, or to manufacture, use or sell anything it may describe. Reproduction, disclosure or use without specific written authorization of Pulse is strictly forbidden.

Description: Bluetooth, WiFi Antenna

Series: The Blue Dot

PART NUMBER: W3092

CHARTS

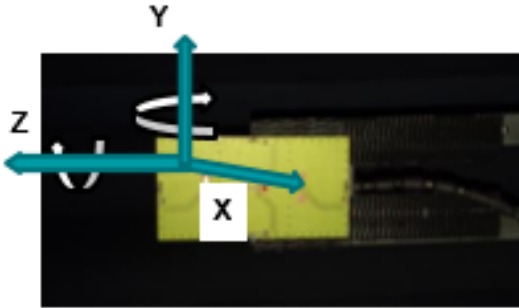

Radiation pattern

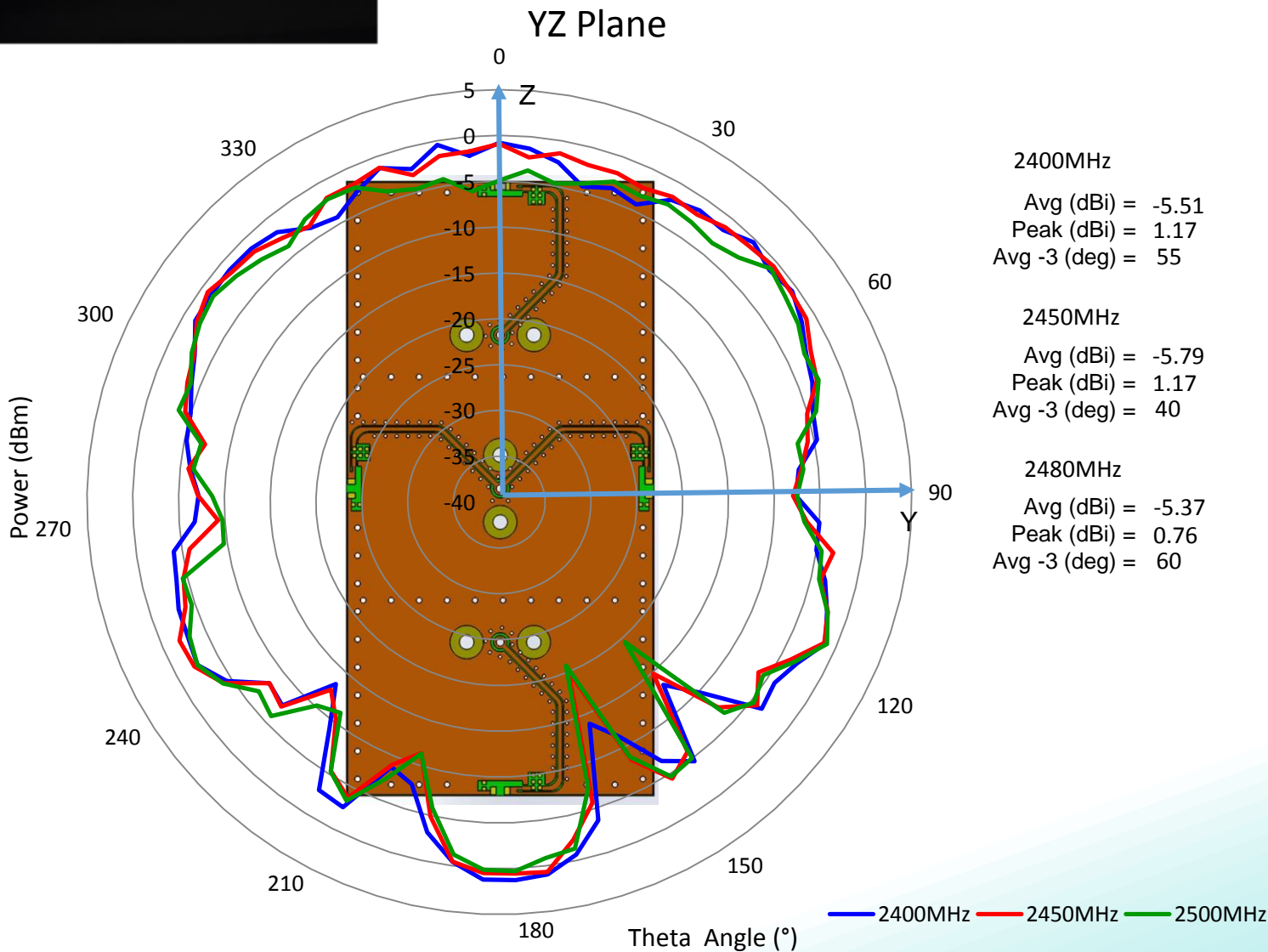

Issue: 1639

In the effort to improve our products, we reserve the right to make changes judged to be necessary.

CONFIDENTIAL AND PROPRIETARY INFORMATION

This document contains confidential and proprietary information of Pulse Electronics, Inc. (Pulse) and is protected by copyright, trade secret and other state and federal laws. Its receipt or possession does not convey any rights to reproduce, disclose its contents, or to manufacture, use or sell anything it may describe. Reproduction, disclosure or use without specific written authorization of Pulse is strictly forbidden.

Description: Bluetooth, WiFi Antenna

Series: The Blue Dot

PART NUMBER: W3092

**PACKAGING**

**Taping Package and Label Marking: (unit: mm)**

- (1) Quantity/Reel: 5000pcs/Reel
- (2) Carrier tape dimensions

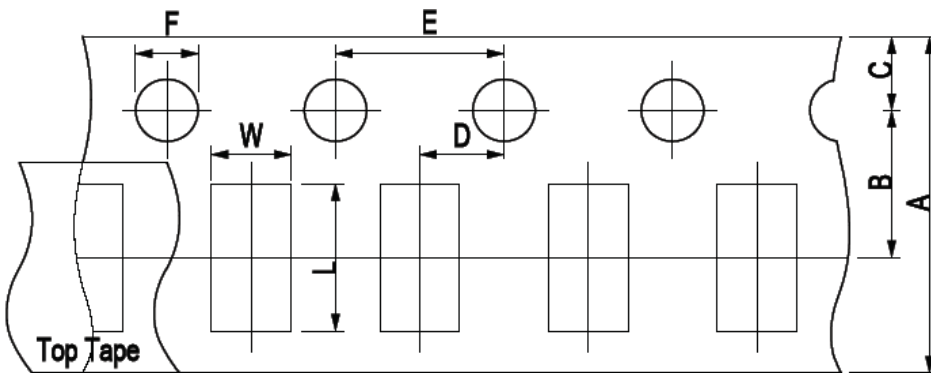

Type	A	B	C	D	E	F	L	W
ACA2012	8.00±0.30	3.50±0.05	1.75±0.10	2.00±0.05	4.00±0.10	1.50±0.10	2.30±0.10	1.55±0.10

**(3) Taping reel dimensions**

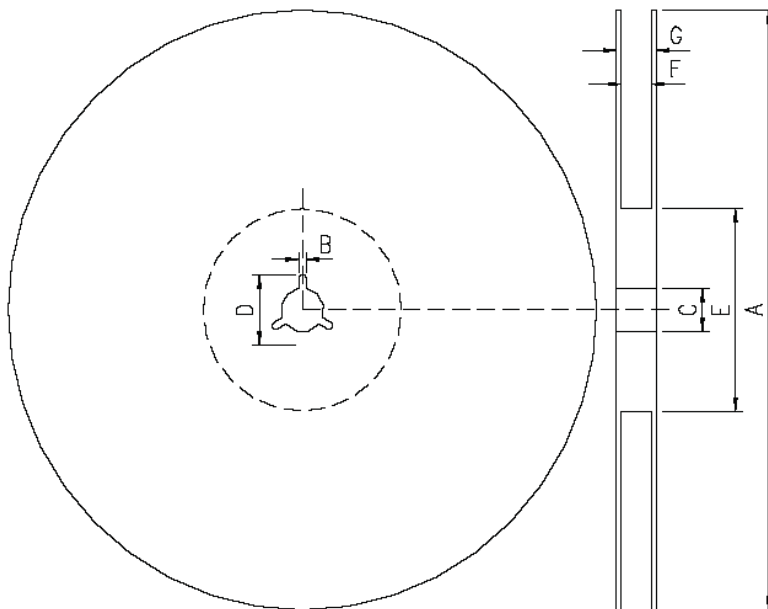

A	178.0±2.0
B	2.0±0.5
C	13.0±0.5
D	21.0±0.8
E	62.0±1.5
F	9.0±0.5
G	13.0±1.0

Issue: 1639

In the effort to improve our products, we reserve the right to make changes judged to be necessary.

CONFIDENTIAL AND PROPRIETARY INFORMATION

This document contains confidential and proprietary information of Pulse Electronics, Inc. (Pulse) and is protected by copyright, trade secret and other state and federal laws. Its receipt or possession does not convey any rights to reproduce, disclose its contents, or to manufacture, use or sell anything it may describe. Reproduction, disclosure or use without specific written authorization of Pulse is strictly forbidden.