





2/2 or 3/2-way Whisper Valve with media separation

- Highest chemical resistance
- Compact design with 8.9 mm installation width
- DN 0.8 mm (vacuum up to 5 bar) and 1.2 mm (vacuum up to 3 bar)
- Very fast, almost silent switching with <20 dB (A) and very low power consumption
- High back-pressure tightness, excellent cleanability and 100 % duty cycle



Product variants described in the data sheet may differ from the product presentation and description.

Can be combined with

	Type 2503 ▶ Cable plug for whisper valve Types 6712 and 6724
	Type 8763 ▶ Pressure controller for precise time-pressure dosing

Type description

Many fluidic processes moving closer to where they are actually required. In the field of medical devices, for example, treatments such as dialysis can be provided to patients in convenient surroundings at home. Washing units in analytical equipment are positioned on the pipetting arm or directly on the print head in printing applications. This imposes different requirements on the components used. Solenoid valves must be able to switch without being heard. They need to be smaller and lighter to be used in mobile devices. However, their ability to achieve a long service life and excellent switching characteristics is every bit as important. The Whisper Valve Type 6724 combines all of these traits and, thanks to its modular structure and range of available material variants, this valve is universally applicable.

Table of contents

1. General technical data	3
1.1. General data.....	3
1.2. Medium pressure	4
2. Product versions	5
3. Circuit functions	5
4. Materials	5
4.1. Bürkert resistApp	5
4.2. Material specifications	6
5. Dimensions	6
5.1. Bürkert sub-base (9 x 26).....	6
5.2. Bürkert sub-base (9 x 26) interface.....	7
5.3. Bürkert sub-base (26 x 57) horizontal.....	8
5.4. Bürkert sub-base (26 x 57) interface.....	8
5.5. Threaded port version (UNF 1/4"-28)	9
5.6. Tube connector version.....	10
6. Device/Process connections	11
6.1. Pin assignment	11
7. Ordering information	11
7.1. Bürkert eShop.....	11
7.2. Bürkert product filter	11
7.3. Ordering chart	12
Standard version.....	12
Impulse version.....	13
7.4. Ordering chart accessories.....	13
Manifolds	13
Cable plug Type 2503	13
Fittings and hoses.....	14

1. General technical data

1.1. General data

Product properties	
Dimensions	Detailed information can be found in chapter "5. Dimensions" on page 6.
Material	
Body	PEEK or PPS (PVDF on request)
Seal	FFKM, EPDM, FKM or FFKM HCR (High Chemical Resistance)
Internal volume	Bürkert sub-base (9 x 26): approx. 38 µl Bürkert sub-base (26 x 57) horizontal: approx. 93 µl Threaded version UNF ¼"-28: approx. 59 µl Tube connector: approx. 68 µl
Orifice	
Standard version	DN 0.8 or DN 1.2
Impulse version	DN 1.2
FFKM HCR version	DN 1.2
Circuit function	Detailed information can be found in chapter "3. Circuit functions" on page 5.
Typical product service life	10 million switching cycles (acc. to laboratory duration tests) ¹⁾
Performance data	
Pressure range	Detailed information can be found in chapter "1.2. Medium pressure" on page 4.
Switching noise	30 dB (A) (<20 dB (A) on request ²⁾)
Switching time ³⁾	Opening: approx. 3 ms (Pressure build-up 0...10 %) Closing: approx. 3 ms (Pressure reduction 100...90 %)
Electrical data	
Power supply	12 V DC, 24 V DC (other voltages on request)
Duty cycle ⁴⁾	100 % continuous operation
Nominal power	
Standard version	1 W ⁵⁾
Impulse version	1.25 W ⁵⁾ (impulse length min. 500 ms)
FFKM HCR version	1.25 W ⁵⁾
Voltage tolerance	
Standard version	± 10 % (incl. residual ripple)
Impulse version	± 5 % (incl. residual ripple)
FFKM HCR version	± 5 % (incl. residual ripple)
Medium data	
Operating medium	Resistant to neutral and aggressive gases and liquids. For more detailed information, see the chapter "4.1. Bürkert resistApp" on page 5.
Medium temperature	
Standard version	FFKM: + 15 °C...+50 °C (59 °F...122 °F) FKM: 0 °C...+50 °C (32 °F...122 °F) EPDM: 0 °C...+50 °C (32 °F...122 °F)
Impulse version	FFKM: + 15 °C...+40 °C (59 °F...104 °F) FKM: 0 °C...+40 °C (32 °F...104 °F) EPDM: 0 °C...+40 °C (32 °F...104 °F) (Higher temperature range on request)
FFKM HCR version	FFKM HCR: + 15 °C...+ 50 °C (59 °F...122 °F) ⁶⁾
Viscosity	Max. 21 mm ² /s
Process/Port connection & communication	
Electrical connection ⁷⁾	Plug with detent, pin spacing 2 mm, see data sheet Type 2503 ▶
Port connection	Bürkert sub-base (9 x 26) Bürkert sub-base (26 x 57) horizontal Threaded version UNF ¼"-28 Tube connector version
Approvals and Certificates	
Suitable for food industry	FDA – on request, only with sealing material EPDM
Oxygen application	Oxygen suitability of materials in contact with fluid (BAM) – on request, only with sealing material FKM
Degree of protection	IP10
Suitable for drinking water	KTW (W270) – on request, only with sealing material EPDM

Environment and installation

Installation As required, preferably with actuator upright

Ambient temperature

FFKM	+ 15 °C...+50 °C (59 °F...122 °F)
FKM	0 °C...+50 °C (32 °F...122 °F)
EPDM	0 °C...+50 °C (32 °F...122 °F)
FFKM HCR	+ 15 °C...+50 °C (59 °F...122 °F)

- 1.) The service life depends on the medium, temperature, pressure, sealing material and individual operating conditions.
- 2.) May be higher with impulse version. <20 dB(A) with optional soft-close electronics only possible in conjunction with standard valve.
- 3.) Measurement at 2 bar and +20 °C at the valve outlet acc. to DIN ISO 12238:2001
- 4.) Max. housing temperature must not exceed 110 °C. In continuous operation care must be taken to ensure sufficient heat dissipation (convection) at the metal surface of the valve. Overheating of the valve can lead to damage.
- 5.) No further power reduction possible
- 6.) Reduced shifting performance at 15 °C
- 7.) Please order socket with flying leads separately (see "7.4. Ordering chart accessories" on page 13).
Other suitable connectors are, for example W+P: Series 521 (socket 521S-02-1; contact 521S-01-2-00) or JST (socket PHR-2; contact SPH-002GW-P0.5S), version 04/2015). As a PCB connector we recommend a pin size of 0.5 x 0.5 mm, grid size 2 mm and a maximum size of the connector of 4.9 x 2.5 mm. E.g. Samtec SQT-102-01-x-S (x=L or F) or W+P Series 257 Part No. 257-002-1-50-00-6.

1.2. Medium pressure

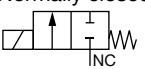
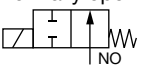
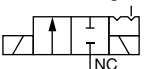
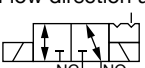
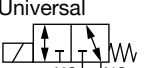
Circuit function	Orifice [mm]	Pressure range under [bar]			Max. differential pressure [bar]
		NC	COM	NO	
CF A 2/2-way solenoid valve Direct-acting Normally closed 	0.8	Vac...5 ¹⁾²⁾	N/A	- ²⁾³⁾	5
	1.2	Vac...3 ¹⁾	N/A	- ²⁾³⁾	3
	1.2 (with boost electronics ⁴⁾)	Vac...7 ¹⁾	N/A	- ²⁾³⁾	7
	1.2 (with seal material FFKM HCR)	Vac...2 ¹⁾	N/A	- ²⁾³⁾	2
CF B 2/2-way solenoid valve Direct-acting Normally open 	0.8	0...3 ¹⁾³⁾	N/A	Vac...5	5
	1.2	- ¹⁾²⁾³⁾	N/A	Vac...2	2
CF P 2/2-way impulse solenoid valve Direct-acting 	1.2	Vac...2 ¹⁾	N/A	- ²⁾³⁾	2
CF S 3/2-way impulse solenoid valve Direct-acting Flow direction unrestricted 	1.2	Vac...2 ¹⁾	0...2 ³⁾	Vac...2	2
CF T 3/2-way solenoid valve Direct-acting Flow direction optional Universal 	0.8	Vac...5 ¹⁾	0...3 ³⁾	Vac...5	5
	1.2	Vac...2 ¹⁾	0...2 ³⁾	Vac...2	2
	1.2 (with boost electronics ⁴⁾)	Vac...7 ¹⁾	0...5 ³⁾	Vac...2	7

- 1.) Connect technical vacuum (-0.8 bar) to NC or NO. If vacuum is connected to (COM/OUT), significantly reduced flow must be expected.
- 2.) Up to 2 bar, the flow direction is permissible even against the specification.
- 3.) Low vacuum due to back pressure at media flow permissible. In case of continuous operation with higher vacuum, there is a risk of flow reduction. In case of doubt, please contact your Bürkert sales office.
- 4.) For information on the optional boost electronics see chapter "7.4. Ordering chart accessories" on page 13.

2. Product versions

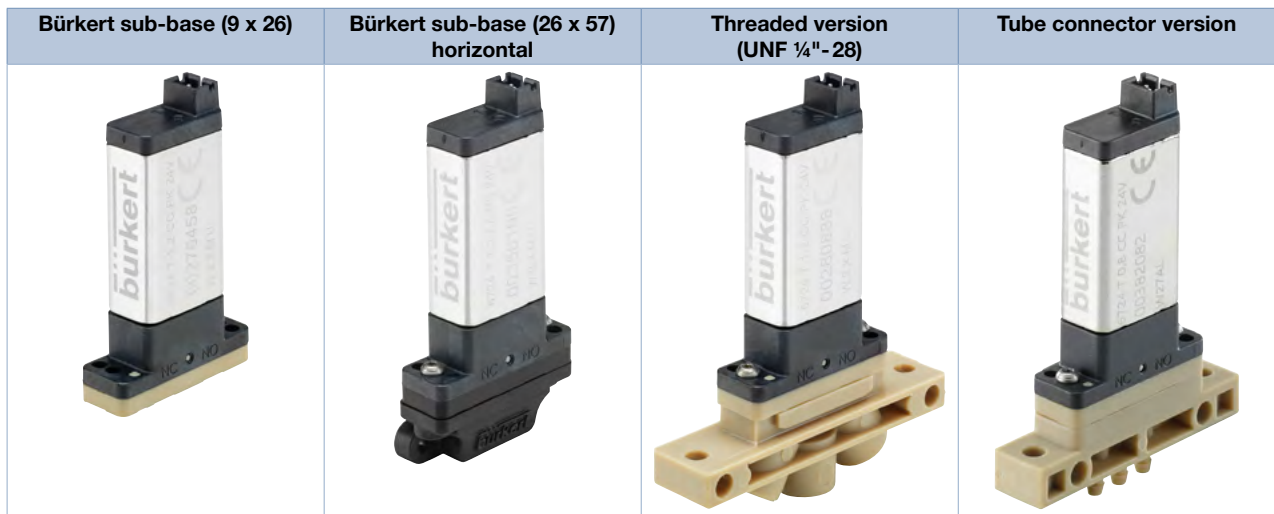

3. Circuit functions

Circuit functions	Description
	Circuit function A (CF A) 2/2-way solenoid valve Direct-acting Normally closed
	Circuit function B (CF B) 2/2-way solenoid valve Direct-acting Normally open
	Circuit function P (CF P) 2/2-way impulse solenoid valve Direct-acting
	Circuit function S (CF S) 3/2-way impulse solenoid valve Direct-acting Flow direction unrestricted
	Circuit function T (CF T) 3/2-way solenoid valve Direct-acting Flow direction optional Universal

4. Materials

4.1. Bürkert resistApp

Bürkert resistApp – Chemical resistance chart

You want to ensure the reliability and durability of the materials in your individual application case? Verify your combination of media and materials on our website or in our resistApp.

[Start chemical resistance check](#)

4.2. Material specifications

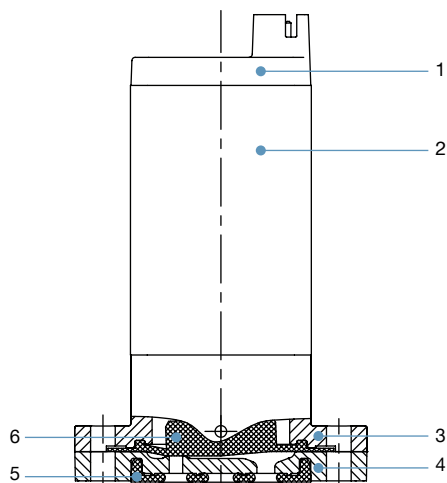

No.	Element	Material
1	Cap	LCP
2	Coil housing	nickel-plated
3	Valve body	PPS
4	Fluid housing (medium contact)	PEEK or PPS (PVDF on request)
5	Sub-base seal (medium contact)	FFKM, EPDM or FKM
6	Diaphragm (medium contact)	FFKM, EPDM, FKM or FFKM HCR (High Chemical Resistance)

5. Dimensions

5.1. Bürkert sub-base (9 x 26)

Note:

- Dimensions in mm
- Including fastening screws M2 x 10

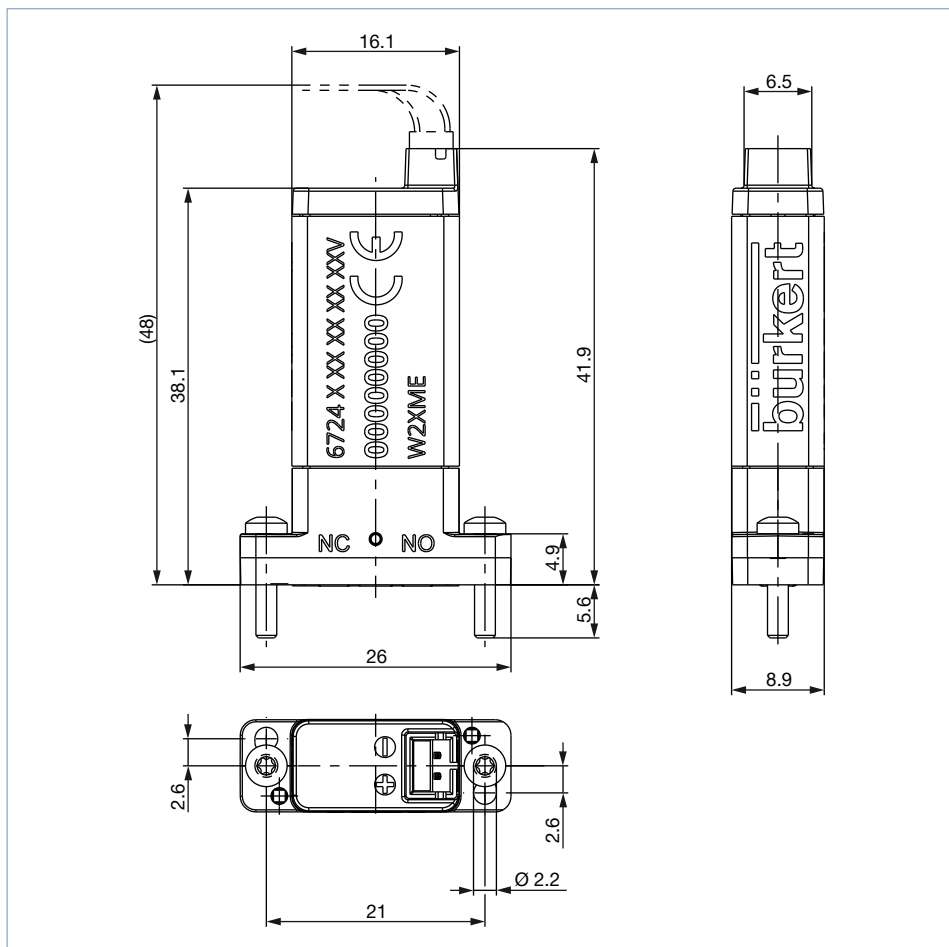

DTS 1000262565 EN Version: R Status: RL (released | freigegeben | valide) printed: 02.02.2024

5.2. Bürkert sub-base (9 x 26) interface

Note:

Dimensions in mm

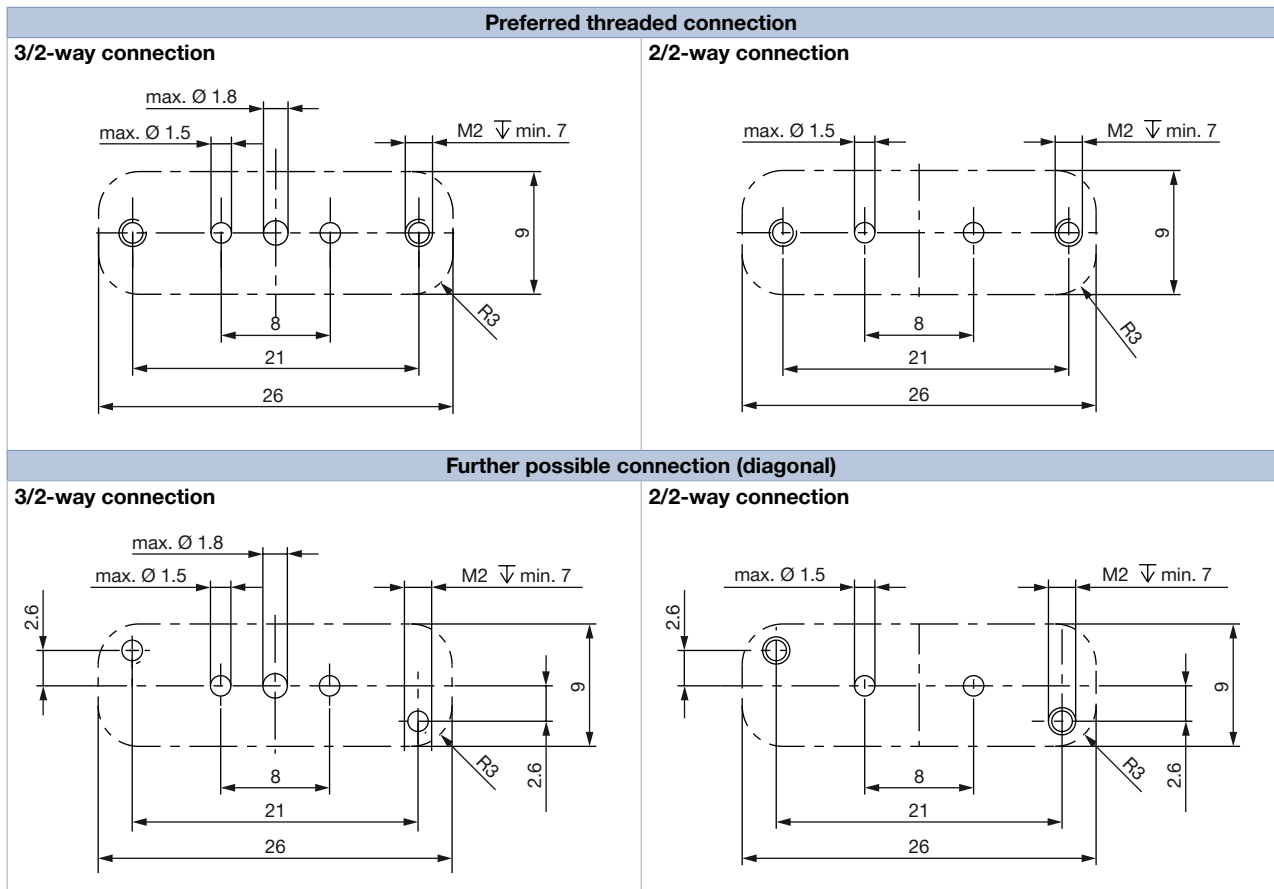

DTS 1000262565 EN Version: R Status: RL (released | freigegeben | valide) printed: 02.02.2024

5.3. Bürkert sub-base (26 x 57) horizontal

Note:

- Dimensions in mm
- Optional: Sub-base can be turned by 180°
- Including fastening screws M2 x 6

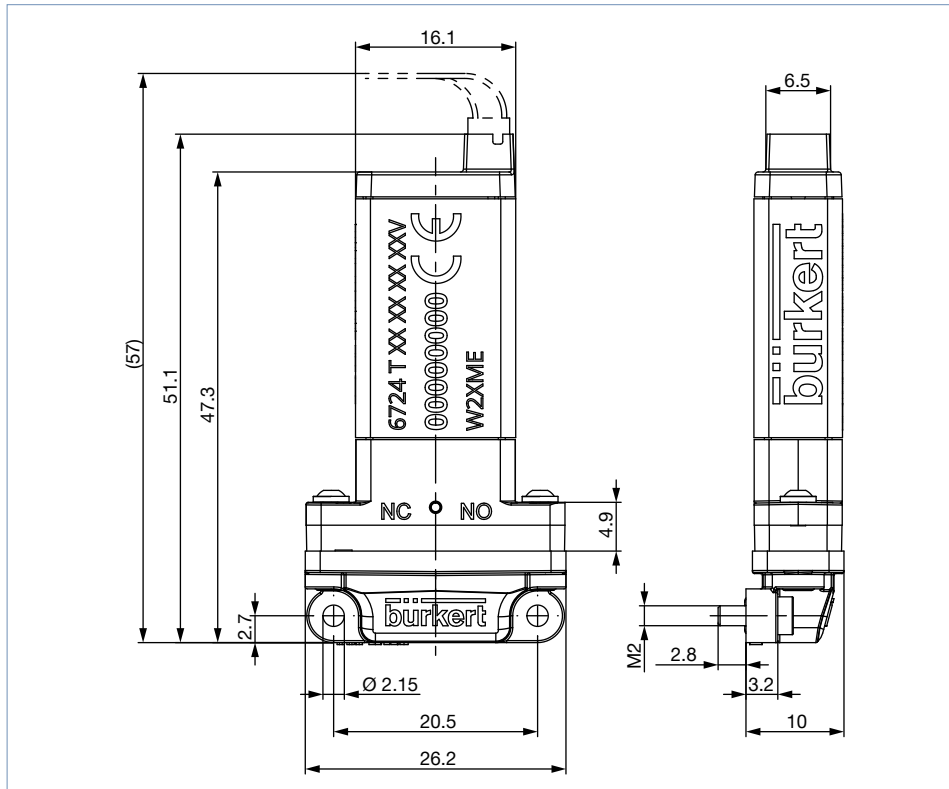

5.4. Bürkert sub-base (26 x 57) interface

Note:

Dimensions in mm

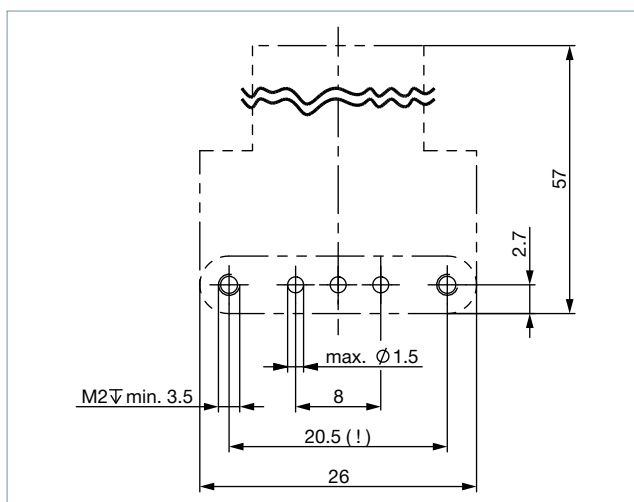

5.5. Threaded port version (UNF 1/4"-28)

Note:

Dimensions in mm

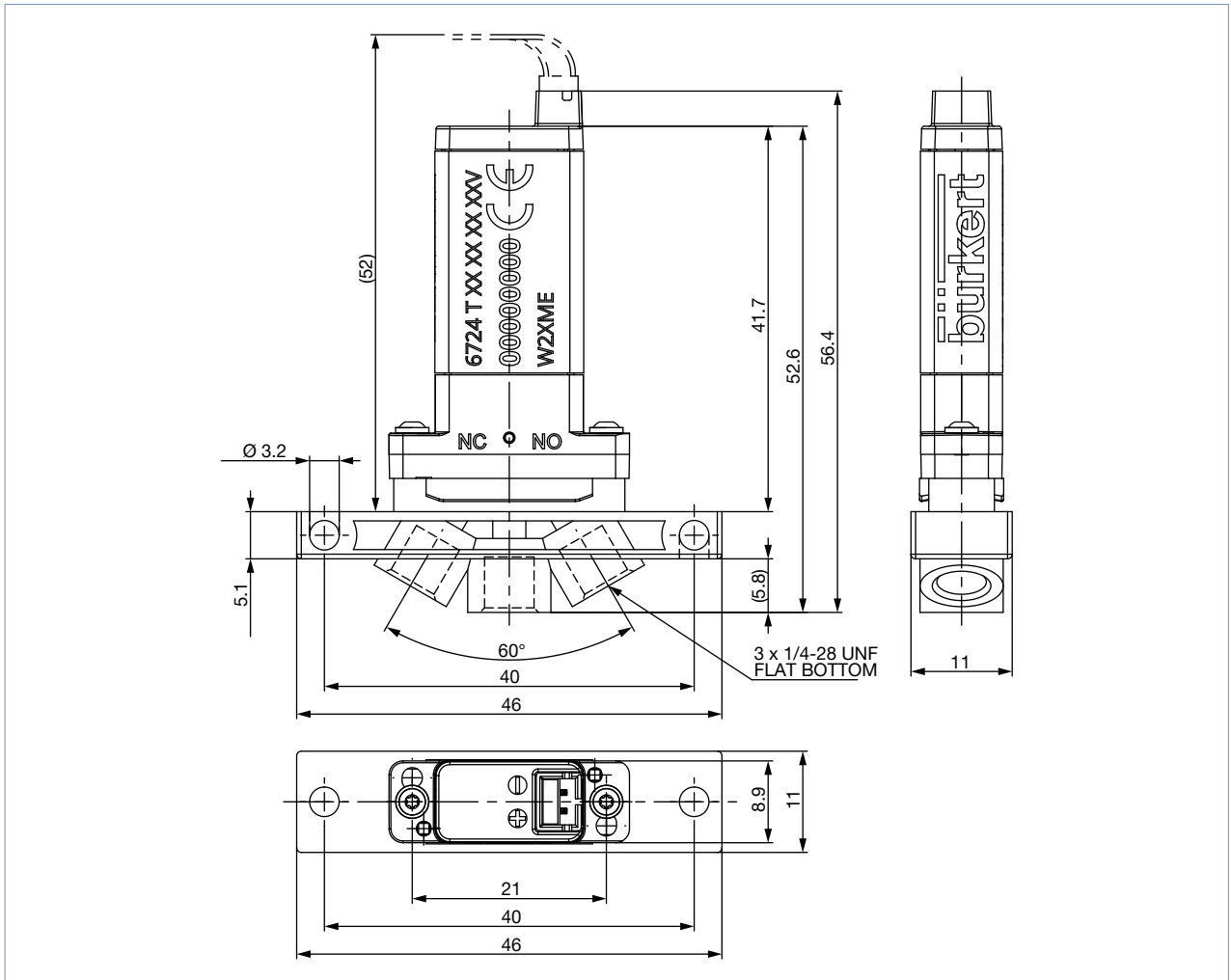

5.6. Tube connector version

Note:

Dimensions in mm

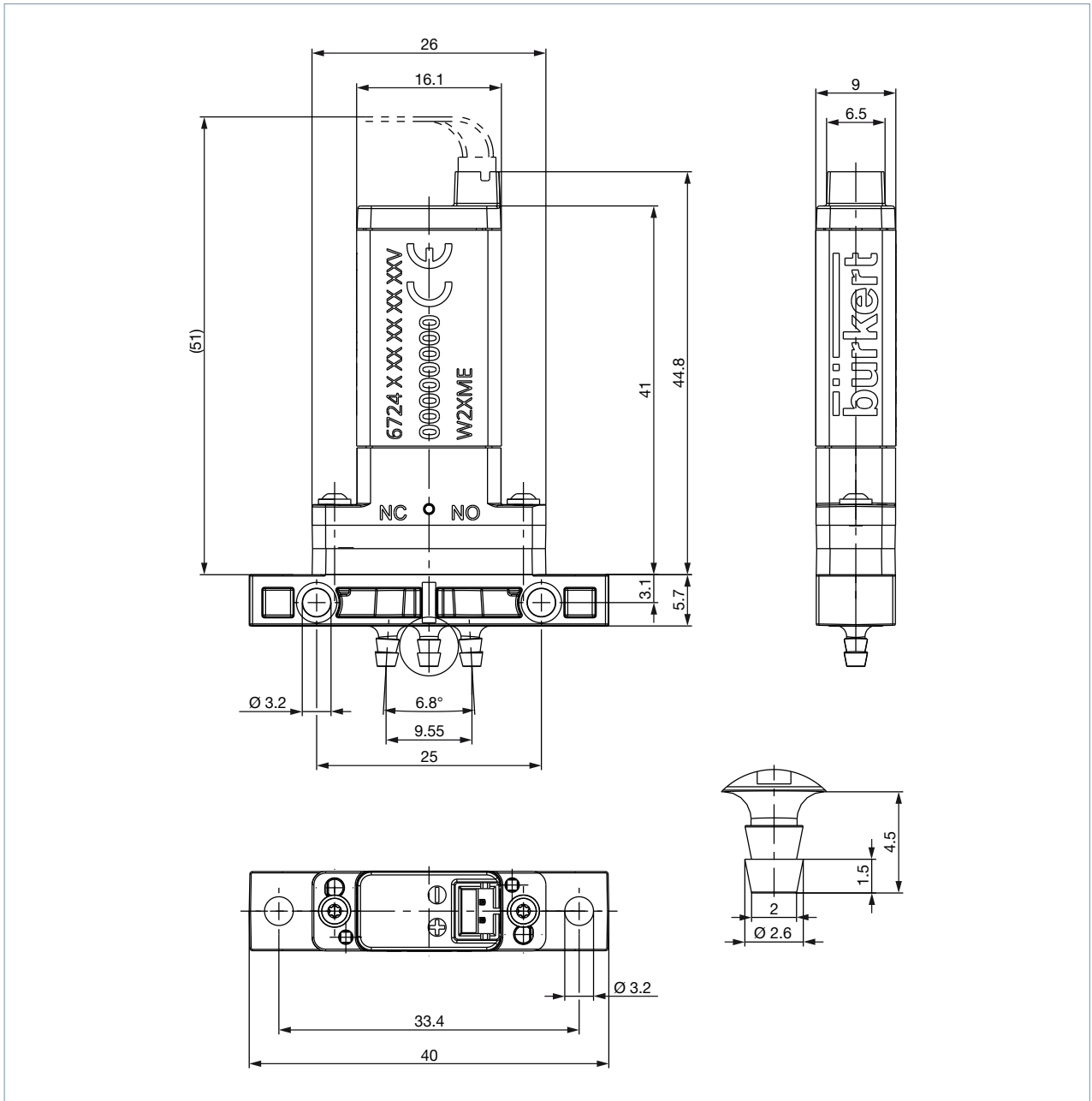

6. Device/Process connections

6.1. Pin assignment

Electrical control for impulse versions		Impulse 500 ms	
		1	2
P 2/2-way Impulse	NC (open)	-	+
	NC (closed)	+	-
S 3/2-way Impulse	NC ⇄ COM (open)	-	+
	NO ⇄ COM (open)	+	-

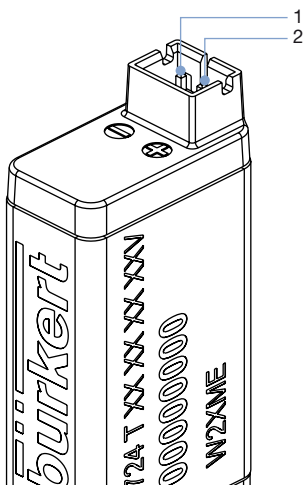

7. Ordering information

7.1. Bürkert eShop



Bürkert eShop – Easy ordering and quick delivery

You want to find your desired Bürkert product or spare part quickly and order directly? Our online shop is available for you 24/7. Sign up and enjoy all the benefits.

[Order online now](#)

7.2. Bürkert product filter



Bürkert product filter – Get quickly to the right product

You want to select products comfortably based on your technical requirements? Use the Bürkert product filter and find suitable articles for your application quickly and easily.

[Try out our product filter](#)

DTS 1000262565 EN Version: R Status: RL (released | freigegeben | valide) printed: 02.02.2024

7.3. Ordering chart

Standard version

Note:

- Please order plug connector with lead or electronic separately (see “7.4. Ordering chart accessories” on page 13).
- Including mounting screws for the following port connections:
Bürkert sub-base (9 x 26): M2x10-TORX T6-A2
Bürkert sub-base (26 x 57) horizontal: M2x6-TORX T6-A2
- Mounting screws M1.6x8-ISK for replacing Type 6604 with Type 6724 available on request.

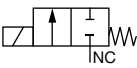
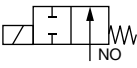
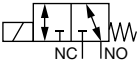
Circuit function	Port connection	Orifice	Q _{Nn} value air ^{2.)}	K _V value water ^{1.)}	C _V value water	Voltage/ frequency	Pressure range ^{3.)}	Max. pressure difference	Body material	Seal material	Article no.				
		[mm]	[l/min]	[m ³ /h]	[gpm]	[V]	[bar]	[bar]							
CF A 2/2-way solenoid valve Direct-acting Normally closed 	Bürkert sub-base (9 x 26)	0.8	10.7	0.01	0.012	24	Vac...5	5	PEEK	FFKM	299245				
									PPS	FKM	299248				
										EPDM	299247				
	UNF 1/4"-28		10.7	0.01	0.012	24	Vac...5	5	PEEK	FFKM	299246				
	Tube connector		10.7	0.01	0.012	24	Vac...5	5	PEEK	FFKM	382088				
										EPDM	382643				
	Bürkert sub-base (26 x 57) horizontal		10.7	0.01	0.012	24	Vac...5	5	PPS	EPDM	20069044				
	Bürkert sub-base (9 x 26)	1.2	28	0.026	0.03	24	Vac...3	3	PEEK	FFKM	281506				
									PPS	FKM	281936				
									EPDM	281934					
UNF 1/4"-28		28 ^{4.)}	0.026 ^{4.)}	0.03 ^{4.)}	24	Vac...3	3	PEEK	FFKM	281933					
									FKM	295793					
Bürkert sub-base (9 x 26)		28	0.026	0.03	24	Vac...2	2	PEEK	FFKM HCR	20048280					
UNF 1/4"-28		28 ^{4.)}	0.026 ^{4.)}	0.03 ^{4.)}	24	Vac...2	2	PEEK	FFKM HCR	20075595					
CF B 2/2-way solenoid valve Direct-acting Normally open 	Bürkert sub-base (9 x 26)	1.2	28	0.026	0.03	24	Vac...2	2	PEEK	FFKM	281507				
CF T 3/2-way solenoid valve Direct-acting Flow direction optional Universal 	Bürkert sub-base (9 x 26)	0.8	10.7	0.01	0.012	24	0...3 ^{5.)}	5	PEEK	FFKM	299249				
													PPS	FKM	299252
													12		EPDM
							24				299251				
	UNF 1/4"-28		10.7	0.01	0.012	24	0...3 ^{5.)}	5	PEEK	FFKM	299250				
	Tube connector		10.7	0.01	0.012	24	0...3 ^{5.)}	5	PEEK	FFKM	382082				
										EPDM	382644				
	Bürkert sub-base (26 x 57) horizontal		10.7	0.01	0.012	24	0...3 ^{5.)}	5	PPS	FKM	20069046				
										EPDM	20069045				
	Bürkert sub-base (9 x 26)	1.2	28	0.026	0.03	12	Vac...2	2	PEEK	FFKM	295322				
					24				FFKM	276458					
						PPS			FKM	281937					
									EPDM	281935					
UNF 1/4"-28		28 ^{4.)}	0.026 ^{4.)}	0.03 ^{4.)}	24	Vac...2	2	PEEK	FFKM	280888					
Bürkert sub-base (9 x 26)		28 ^{4.)}	0.026 ^{4.)}	0.03 ^{4.)}	24	Vac...2	2	PEEK	FFKM HCR	20075596					
UNF 1/4"-28		28 ^{4.)}	0.026 ^{4.)}	0.03 ^{4.)}	24	Vac...2	2	PEEK	FFKM HCR	20054962					

1.) Measurement at 1 bar and +20 °C at the valve inlet and free outlet

2.) Converted to standard conditions

- 3.) Connect technical vacuum (-0.8 bar) to NC or NO. If vacuum is connected to (COM/OUT), significantly reduced flow must be expected.
- 4.) K_v value of the valve. The UNF connections have a diameter of 1.2 mm; in conjunction with conventional connection technology (10 cm hose each with ID= 1.6 mm), this results in practical values of $K_v=0.015 \text{ m}^3/\text{h}$; $C_v=0.017 \text{ gpm}$; $Q_{Nn}=21.8 \text{ l/min}$.
- 5.) Applies to pressure connection to COM. For pressure connection to NC or NO Vac...5 bar applies.

Impulse version

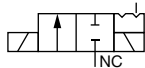
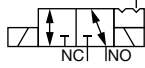
Circuit function	Port connection	Orifice	Q_{Nn} value air ^{2.)}	K_v value water ^{1.)}	C_v value water	Voltage/frequency	Pressure range ^{3.)4.)}	Max. pressure difference	Body material	Seal material	Article no.
		[mm]	[l/min]	[m ³ /h]	[gpm]						
CF P 2/2-way impulse solenoid valve Direct-acting 	Bürkert sub-base (9 x 26)	1.2	25	0.024	0.027	24	Vac...2	2	PPS	FKM	355749
						24			PEEK	FFKM	355744
						12					355750
	UNF 1/4"-28		25 ^{5.)}	0.024 ^{5.)}	0.027 ^{5.)}	24	Vac...2	2			355745
CF S 3/2-way impulse solenoid valve Direct-acting Flow direction unrestricted 	Bürkert sub-base (9 x 26)	1.2	28	0.026	0.03	24	Vac...2	2	PPS	FKM	355756
						24			PEEK	FFKM	355754
						12					20005293
	UNF 1/4"-28		28 ^{5.)}	0.026 ^{5.)}	0.03 ^{5.)}	24	Vac...2	2			355755



- 1.) Measurement at 1 bar and +20 °C at the valve inlet and free outlet
- 2.) Converted to standard conditions
- 3.) Pressure data: Overpressure to atmospheric pressure
- 4.) Connect technical vacuum (-0.8 bar) to NC or NO. If vacuum is connected to (COM/OUT), significantly reduced flow must be expected.
- 5.) K_v value of the valve. The UNF connections have a diameter of 1.2 mm; in conjunction with conventional connection technology (10 cm hose each with ID= 1.6 mm), this results in practical values of $K_v=0.015 \text{ m}^3/\text{h}$; $C_v=0.017 \text{ gpm}$; $Q_{Nn}=21.8 \text{ l/min}$.

7.4. Ordering chart accessories

Manifolds

Note:
Customised for connecting plates, on request.

Cable plug Type 2503

Accessories	Description	Article no.
	Cable plug with 500 mm flying leads AWG 24 For further information please refer to data sheet Type 2503 ▶.	689974
	Cable plug with 500 mm flying leads and boost-close electronics to increase the permissible pressure under NC. For further information refer to the operating instructions for Type 2503 ▶ BoostClose or see data sheet Type 2503 ▶.	689998

DTS 1000262565 EN Version: R Status: RL (released | freigegeben | valide) printed: 02.02.2024

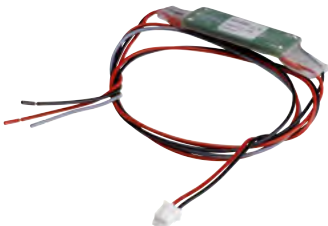
Accessories	Description	Article no.
	<p>Cable plug with 500 mm flying leads and Soft Close Elektronik for noise minimization. For further information refer to the operating instructions for Type 2503 ▶ Soft-Close or see data sheet Type 2503 ▶.</p>	<p>689999 </p>
	<p>The electronic accessory "Impulse" was specially developed for the impulse version of the solenoid valve Type 6724. With the help of the electronics, the impulse valve is activated by reversing the polarity of the voltage. The electronics automatically choose the correct polarity for the valve. This means that no polarity reversal logic needs to be provided in the control system. For further information refer to the operating instructions for Type 2503 ▶ Impulse or see data sheet Type 2503 ▶.</p>	<p>366210 </p>

Fittings and hoses

Accessories	Description	Article no.
	<p>Fittings and hoses for UNF connections and hoses see type Type TVU003 ▶.</p>	<p>see data sheet TVU003 ▶</p>

Bürkert – Close to You

For up-to-date addresses
please visit us at
www.burkert.com

DTS 1000262565 EN Version: R Status: RL (released | freigegeben | validé) printed: 02.02.2024

Austria
Belgium
Czech Republic
Denmark
Finland
France
Germany
Italy
Netherlands

Norway
Poland
Spain
Sweden
Switzerland
Turkey
United Kingdom

