

# RH-AG | Bridge handles

Aluminium



## MATERIAL

Anodised aluminium in natural colour, sandblasted and satin finish.

## STANDARD EXECUTIONS

- **RHAG-R:** back mounting, threaded blind holes.
- **RHAG-F:** front mounting, pass-through holes for cylindrical-head screws with hexagon socket, stainless steel nuts and washers, included in the supply.

## SPECIAL EXECUTIONS ON REQUEST

Handles in titanium or black colour.

## OTHER STANDARD EXECUTIONS AVAILABLE

Version RH-AG-CLEAN (see page 413).



# RH-EG | Bridge handles

Stainless steel



## MATERIAL

Stainless steel microfusion, shotblasted surface, semi-matte finish obtained by electropolishing.

## STANDARD EXECUTION

Threaded blind holes.

## SPECIAL EXECUTIONS ON REQUEST

Front mounting.

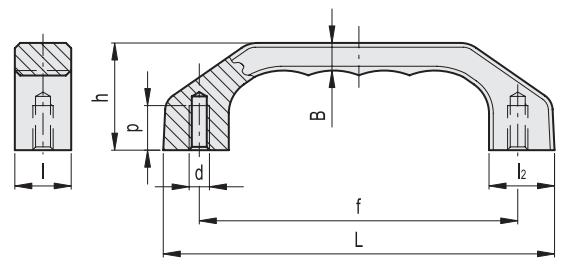
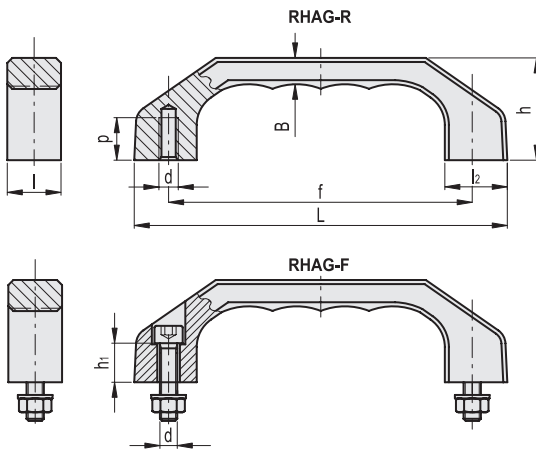

## RHAG-R

Code	f	L	d	p	B	h	l	l <sub>2</sub>	△
RHAG-22.R120.11	120	146	M6	12	10.5	39	22	24	135
RHAG-25.R140.11	140	170	M8	15	12	45	25	28	231
RHAG-28.R160.11	160	194	M8	15	13.5	52	28	32	323

## RHAG-F

Code	f	L	d	h <sub>1</sub>	B	h	l	l <sub>2</sub>	△
RHAG-22.F120.11	120	146	M6x25	15	10.5	39	22	24	125
RHAG-25.F140.11	140	170	M8x30	16	12	45	25	28	222
RHAG-28.F160.11	160	194	M8x30	20	13.5	52	28	32	300

Code	f	L	d	p	B	h	l	l <sub>2</sub>	△
RHEG-1R.140.36	140	170	M8	18	12	45	25	28	594
RHEG-1R.180.36	180	218	M10	20	15	58	32	36	1380