



MATERIAL

Anodised aluminium, black colour.

STANDARD EXECUTIONS

- **GN 826-H**: with adjustable handle type GN 302, lever in RAL 9005 black colour with AISI 303 stainless steel screw and brass locking wedge.
- **GN 826-S**: with grub screw, AISI 303 stainless steel hexagon socket and brass locking wedge.

FEATURES AND APPLICATIONS

GN 826 clamping elements are normally used for the fast locking of spindles controlled by knobs or handwheels without the need for other devices and installations.

By means of a grub screw or an adjustable handle, the brass wedge presses onto the shaft until it locks, eliminating any undesired movement caused by vibration or however ensuring the stable positioning after adjustment.

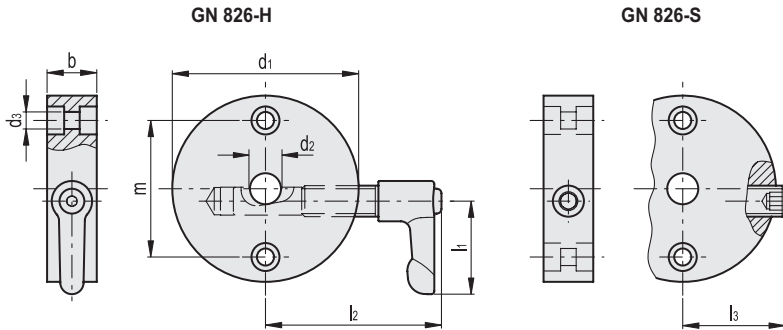
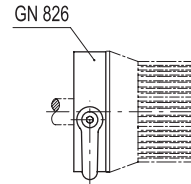

GN 826-H

Code	Description	d1	d2 H7	d3	b	m	l1	l2 max	⚖
GN.36301	GN 826-40-B8-H-ELS	40	8	4.3	16	28	30	50	80
GN.36305	GN 826-40-B10-H-ELS	40	10	4.3	16	28	30	50	80
GN.36311	GN 826-50-B8-H-ELS	50	8	5.3	16	36	30	56	110
GN.36315	GN 826-50-B10-H-ELS	50	10	5.3	16	36	30	56	110
GN.36319	GN 826-50-B12-H-ELS	50	12	5.3	16	36	30	56	119
GN.36331	GN 826-60-B10-H-ELS	60	10	5.3	16	44	30	61	148
GN.36335	GN 826-60-B12-H-ELS	60	12	5.3	16	44	30	61	149

GN 826-S

Code	Description	d1	d2 H7	d3	b	m	l3 max.	⚖
GN.36303	GN 826-40-B8-S-ELS	40	8	4.3	16	28	27	54
GN.36307	GN 826-40-B10-S-ELS	40	10	4.3	16	28	27	54
GN.36313	GN 826-50-B8-S-ELS	50	8	5.3	16	36	32	84
GN.36317	GN 826-50-B10-S-ELS	50	10	5.3	16	36	32	84
GN.36321	GN 826-50-B12-S-ELS	50	12	5.3	16	36	32	89
GN.36333	GN 826-60-B10-S-ELS	60	10	5.3	16	44	36	122
GN.36337	GN 826-60-B12-S-ELS	60	12	5.3	16	44	36	125