

O4E500

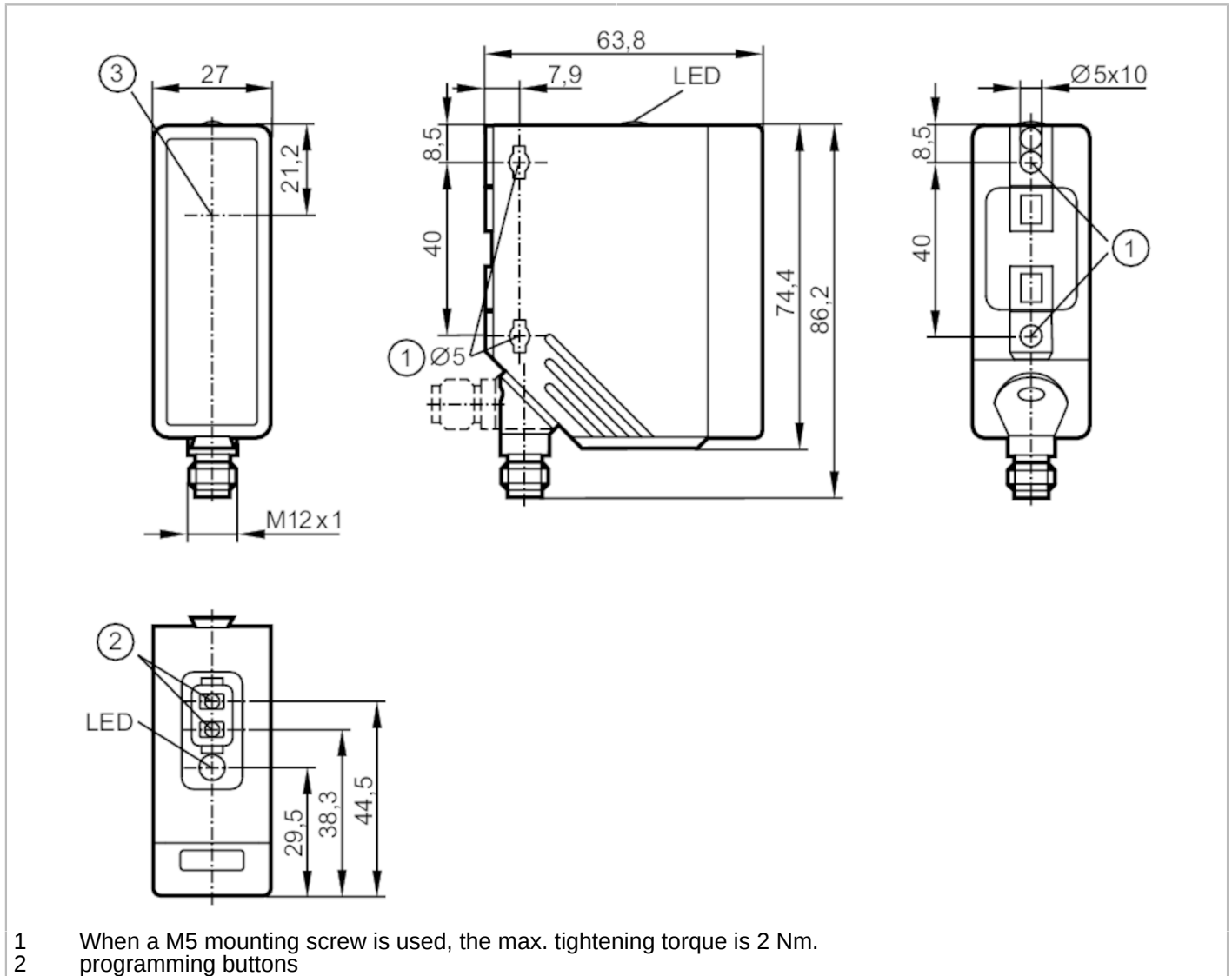

Through-beam sensor receiver

O4E-FPKG/US100



Product characteristics

Type of light	red light
Housing	rectangular
Dimensions [mm]	74.4 x 27 x 63.8

Application

Function principle	Through-beam sensor
--------------------	---------------------

Electrical data

Operating voltage [V]	10...36 DC; ("supply class 2" to cULus)
Current consumption [mA]	12
Protection class	II
Reverse polarity protection	yes
Type of light	red light
Wave length [nm]	624

O4E500



Through-beam sensor receiver

O4E-FPKG/US100

Outputs		
Electrical design		PNP
Output function		light-on/dark-on mode; (programmable)
Max. voltage drop switching output DC	[V]	2.5
Permanent current rating of switching output DC	[mA]	200
Switching frequency DC	[Hz]	1000
Short-circuit protection		yes
Type of short-circuit protection		pulsed
Overload protection		yes
Detection zone		
Transmitter / receiver		receiver
Range	[m]	0...80
Range adjustable		yes
Operating conditions		
Ambient temperature	[°C]	-25...60
Protection		IP 67
Tests / approvals		
EMC		EN 60947-5-2
MTTF	[years]	785
Mechanical data		
Weight	[g]	123.5
Housing		rectangular
Dimensions	[mm]	74.4 x 27 x 63.8
Materials		housing: PA; bezel: stainless steel; operator interface: TPE
Lens material		PMMA
Lens alignment		side lens
Displays / operating elements		
Display	switching status	1 x LED, yellow
Teach function		yes
Electronic lock		yes
Remarks		
Pack quantity		1 pcs.
Electrical connection		

Connector: 1 x M12



Through-beam sensor receiver

O4E-FPKG/US100

Connection

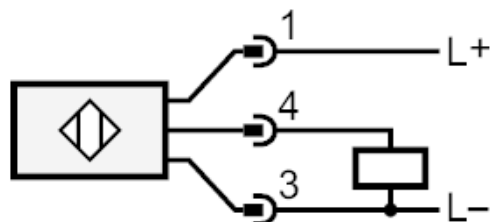

Diagrams and graphs

excess gain graph

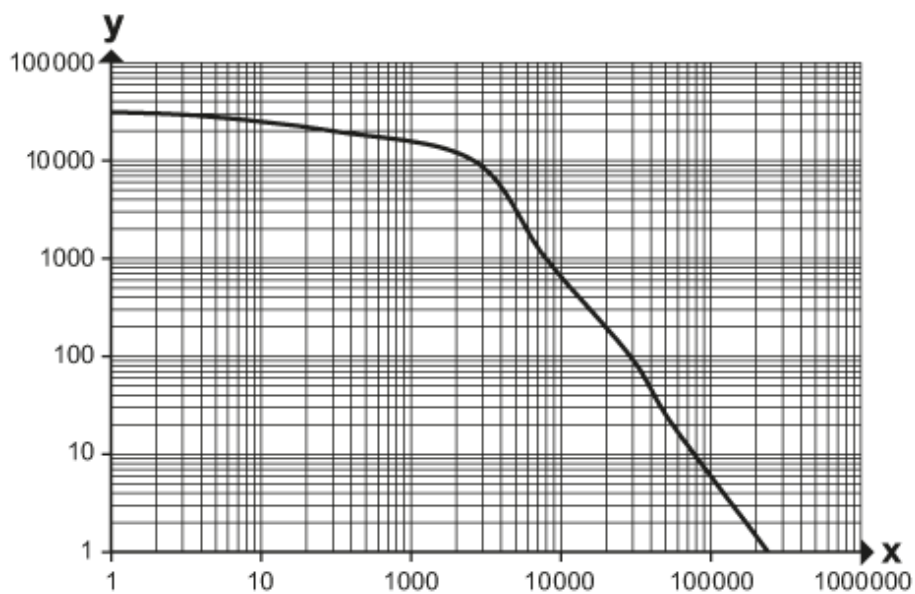

x: Abstand [mm]

y: Funktionsreservfaktor