

## Bevel gears Made from Steel, Straight-Tooth System, Ratio 3.5:1 and 4:1

Material: up to module 2: 11SMn30+SH (1.0715).  
from module 2.5: C45.

Tooth quality 8 modelled on DIN 3967 (from module 2).  
With crowned, milled teeth. Not hardened – not lapped.

Shaft angle = 90°.

The bevel gears only run as a pair at the stated ratio  
and at the same module.

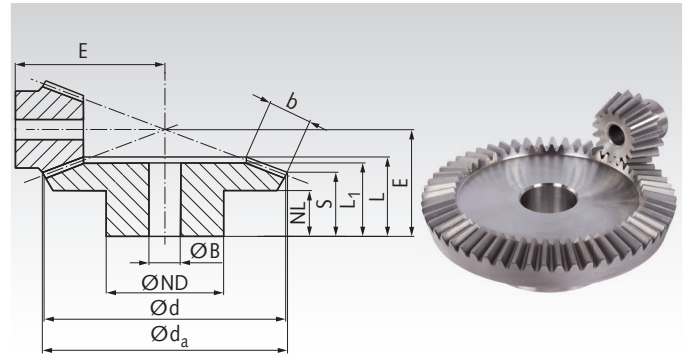

Ordering Details: e.g.:

1 Pair of Bevel Gears Ratio 3.5:1 Mod. 1 16/56 Teeth =

1 Piece Product No. 360 584 00 and

1 Piece Product No. 360 585 00

### Ratio 3.5:1

Product No.	Module	Number of teeth	d <sub>a</sub> mm	d mm	ND mm	NL mm	L <sub>1</sub> mm	L mm	S mm	b mm	BH7 mm	E mm	Torque* Nm	Weight g
360 584 00	1	16	18,7	16	13	7,6	16	16,6	8,4	8,7	5	36	0,127	16
360 585 00	1	56	56,3	56	30	10,0	14	16,7	14,6	8,7	8	22	0,445	130
360 784 00	1,5	16	28,1	24	18	12,2	24	26	13,6	13,1	8	55	0,45	48
360 785 00	1,5	56	84,5	84	50	12	24	27,1	23,8	13,1	15	35	1,58	634
361 084 00	2	16	35,9	32	20	10	25	26,8	12,5	15	10	68	0,99	82
361 085 00	2	56	113,1	112	60	18	31	35,5	31,9	15	25	46	3,47	1200
361 184 00	2,5	16	44,9	40	30	16,5	36	37,7	18,7	20	10	88	6,0	220
361 185 00	2,5	56	141,4	140	80	18	32	37,2	32,4	20	25	50	21,0	2300
361 484 00	3	16	53,9	48	40	15	39	40,6	16,8	25	15	100	10,9	340
361 485 00	3	56	169,7	168	80	18	33	39,8	34,0	25	30	55	38,2	3100
361 884 00	4	16	71,9	64	50	13	42	44,6	16,1	30	20	127	24,7	660
361 885 00	4	56	226,3	224	90	20	40	49,0	42,0	30	30	70	86,5	6900

### Ratio 4:1

Product No.	Module	Number of teeth	d <sub>a</sub> mm	d mm	ND mm	NL mm	L <sub>1</sub> mm	L mm	S mm	b mm	BH7 mm	E mm	Torque* Nm	Weight g
360 592 00	1	15	17,8	15	13	7,7	17,3	17,3	8,4	9,3	5	38	0,117	15
360 593 00	1	60	60,3	60	30	10,0	15	17,1	15,1	9,3	8	22	0,468	160
360 792 00	1,5	15	26,7	22,5	18	14,45	28	28,9	15,5	13,9	8	60	0,41	42
360 793 00	1,5	60	90,4	90	50	12,0	25	27,6	24,6	13,9	15	35	1,64	745
361 092 00	2	15	34,0	30	20	13,5	29	29,9	15,5	15	10	75	1,02	80
361 093 00	2	60	120,9	120	60	20,0	35	40,1	37,0	15	25	50	4,08	1600
361 192 00	2,5	15	42,5	37,5	30	16,1	35	36,8	17,6	20	10	92	5,3	190
361 193 00	2,5	60	151,2	150	80	18,0	33	37,8	33,8	20	25	50	21,2	2600
361 492 00	3	15	51,0	45	30	13,15	38	39,7	15,7	25	10	105	9,6	270
361 493 00	3	60	181,5	180	80	18,0	35	40,6	35,5	25	30	55	38,4	3800
361 892 00	4	15	68,0	60	40	12,5	43	44,8	16,0	30	20	135	21,7	520
361 893 00	4	60	242,0	240	90	20,0	41	50,1	44,0	30	30	70	86,8	8300

\* Basis for calculations see page 316.

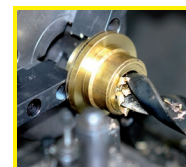

Reworking within  
24h-service possible.  
Custom made parts  
on request.