

# PHILIPS

## Lighting

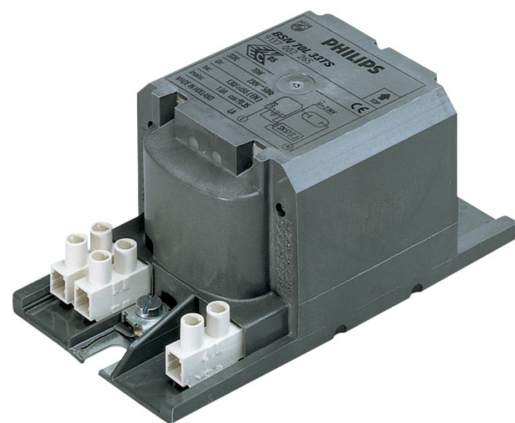

# HID-HeavyDuty BSN semi-parallel for SON/CDO/MH/HPI

**BSN 400 L33-A2-TS 230V 50Hz HD3-166**

Encapsulated electromagnetic copper/iron ballasts for use with an external semi-parallel ignitor for CDM, CDO, MH, HPI (Plus) and SON lamps

### Product data

General Information	
Application Code	L33-A2-TS
Design	HD3-166
Lamp Type	SON/HPI
Number Of Lamps	1 piece/unit

Operating and Electrical	
Input Voltage	230 V
Input Frequency	50 Hz
Power Factor 100% Load (Nom)	0.87
Mains Voltage Performance (AC)	-8%+6%
Mains Voltage Safety (AC)	-10%+10%
Input Current With PF Correction	2.20 A
Input Current Without PF Correction	4.45 A
Power Factor Without PF Compensation (Nom)	0.40
Power Losses (Nom)	28.0 W

Wiring	
Wire Striplength	7.0 mm

Ballast Contact Wire Cross Section	0.70-6.00 mm <sup>2</sup>
Connector Type	Screw

System characteristics	
Capacitor	45µF/250V
Rated Ballast-Lamp Power	400 W
Recommended Ignitor	for SON/CDO lamps SND 58 (913700185166)

Temperature	
T-Storage (Max)	130 °C
T-Storage (Min)	-30 °C
T-Winding (Max)	130 °C
Delta-T Normal Conditions	70 °C

Approval and Application	
Active Temperature Protection	Yes
Approval Marks	CE marking ENEC certificate

## HID-HeavyDuty BSN semi-parallel for SON/CDO/MH/HPI

### Product Data

Full product code	871150005976530
Order product name	BSN 400 L33-A2-TS 230V 50Hz HD3-166
EAN/UPC - Product	8711500059765
Order code	913700226926
Numerator - Quantity Per Pack	1

Numerator - Packs per outer box	4
Material Nr. (12NC)	913700226926
Net Weight (Piece)	4.550 kg

### Dimensional drawing

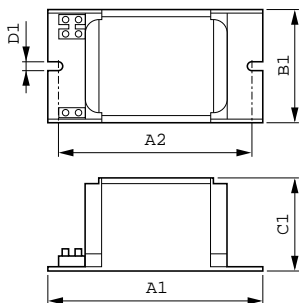

Product	D1	C1	A1	A2	B1
BSN 400 L33-A2-TS 230V 50Hz HD3-166	6.2 mm	84.0 mm	166.0 mm	147.5 mm	102.0 mm

BSN 400 L33-TS 230V 50Hz HD3-166

