

GN 417.1 | Positioning flange

Steel or stainless steel



- 1
- 2
- 3
- 4
- 5
- 6
- 7
- 8
- 9
- 10
- 11
- 12
- 13
- 14
- 15
- 16
- 17
- 18

STANDARD EXECUTIONS

- **GN 417.1-ST-SW**: steel, epoxy resin coating, black colour, matte finish.
- **GN 417.1-NI-GS**: cast CF-8 stainless steel, sandblasted matte finish.

FEATURES AND APPLICATIONS

GN 417.1 positioning flanges are very useful accessories for optimal positioning of indexing plungers GN 417 (see page 798). The slotted pass-through holes allow adjustment during the fixing phase, making it possible to adjust spaces for the doors or compensate for tolerance errors.

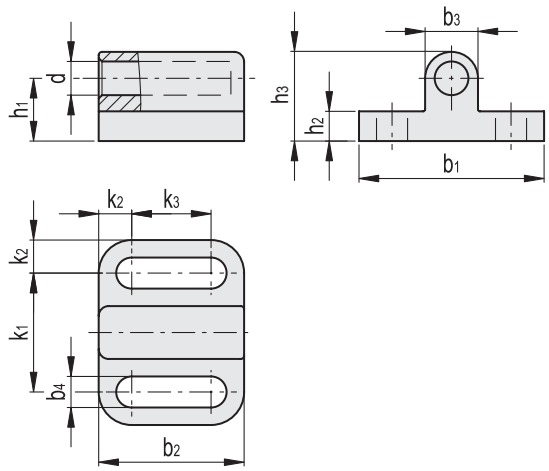
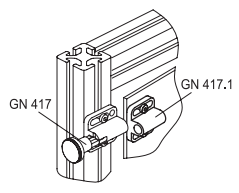

GN 417.1-ST-SW

Code	Description	d+0.1	b1	b2	b3	b4-0.2	h1	h2	h3	k1 ±0.05	k2	k3	△
GN.26334	GN 417.1-4-ST-SW	4.1	22	16.5	6	3.3	7	4	10	14	4	8.5	10
GN.26335	GN 417.1-5-ST-SW	5.1	28	22	8	4.3	9.5	4.5	13.5	18	5	12	20
GN.26336	GN 417.1-6-ST-SW	6.2	32	27.5	10	5.4	10.5	5	15.5	21	5.5	16.5	30
GN.26337	GN 417.1-8-ST-SW	8.2	34	33	12	5.4	12.5	6	18.5	23	5.5	22	50
GN.26338	GN 417.1-10-ST-SW	10.2	39	35	14.5	6.8	14.5	6	21.75	27	6	23	70

GN 417.1-NI-GS



Code	Description	d+0.1	b1	b2	b3	b4-0.2	h1	h2	h3	k1 ±0.05	k2	k3	△
GN.18673	GN 417.1-4-NI-GS	4.1	22	16.5	6	3.3	7	4	10	14	4	8.5	10
GN.18675	GN 417.1-5-NI-GS	5.1	28	22	8	4.3	9.5	4.5	13.5	18	5	12	22
GN.18677	GN 417.1-6-NI-GS	6.2	32	27.5	10	5.4	10.5	5	15.5	21	5.5	16.5	34
GN.18679	GN 417.1-8-NI-GS	8.2	34	33	12	5.4	12.5	6	18.5	23	5.5	22	34
GN.18671	GN 417.1-10-NI-GS	10.2	39	35	14.5	6.8	14.5	6	21.75	27	6	23	70

Indexing and positioning elements