



Part no.: 50117257
BT D21M
Mounting bracket

Figure can vary

Contents

- Technical data
- Dimensioned drawings
- Accessories

Part no.: 50117257 – BT D21M – Mounting bracket

Technical data

Basic data

Suitable for	318 series sensors
--------------	--------------------

Mechanical data

Inner diameter	21 mm
Standard designation, metal mounting device	Steel, galvanized
Design of mounting device	Angle, L-shape
Type of fastening, at system	Through-hole mounting
Type of fastening, at device	Screw type
Type of mounting device	Adjustable
Mounting device material	Metal
ITEM-compatible	No

Classification

Customs tariff number	73182900
eCl@ss 8.0	27279202
eCl@ss 9.0	27273701
ETIM 5.0	EC003015
ETIM 6.0	EC003015

Dimensioned drawings

All dimensions in millimeters

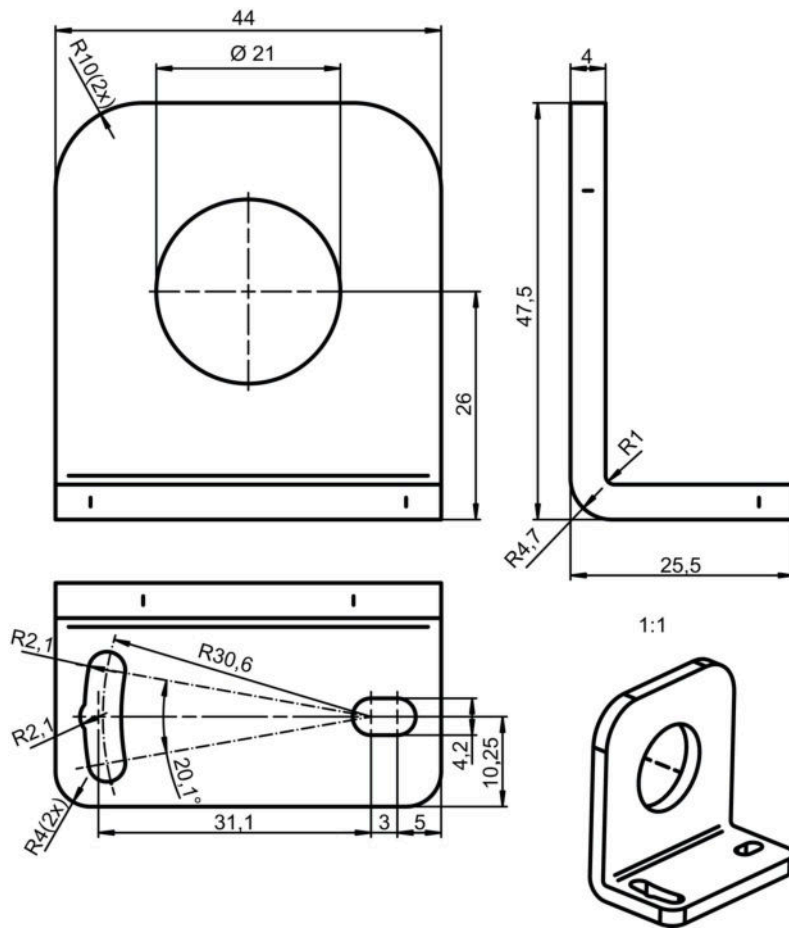

Accessories

Mounting technology - Other

	Part no.	Designation	Article	Description
	50121904	BT318B-OM	Fastening	Design of mounting device: Mounting clamp Fastening, at system: Through-hole mounting Mounting bracket, at device: Screw type Type of mounting device: Swiveling, Adjustable, Turning Material: Plastic

Note

A list with all available accessories can be found on the Leuze electronic website in the Download tab of the article detailed page.