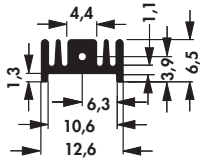
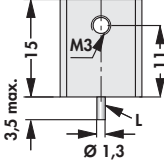
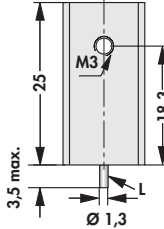
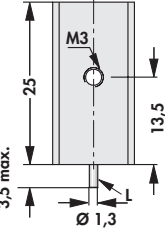
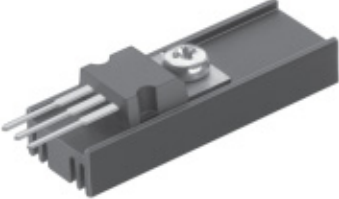
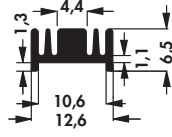
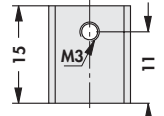
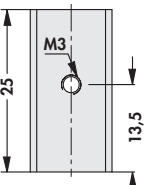
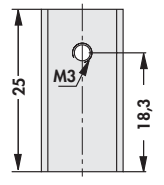
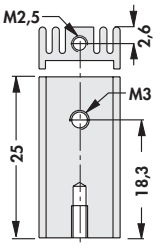
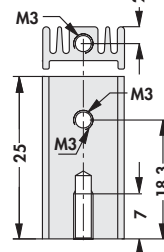

Extruded heatsinks for PCB mounting

- special lengths and drillings on request
- **L** = solderable pins

					SK 95 15 STS SOT 32 S	SK 95 25 STS TO 220	SK 95 25 STS SOT 32			
					art. no.	↳ [mm]	R_{th} [K/W]	⚡		
					SK 95 15 STS SOT 32 S	15	38.5	SOT 32		
					SK 95 25 STS SOT 32	25	36.0	SOT 32		
SK 95 25 STS TO 220	25	36.0	TO 220							
					SK 95 25 1 x M2,5 1 x M3					
					art. no.	↳ [mm]			R_{th} [K/W]	⚡
					SK 95 15	15			38.5	—
					SK 95 15 SOT 32 S	15			38.5	SOT 32
SK 95 25	25	36.0	—							
SK 95 25 TO 220	25	36.0	TO 220							
SK 95 25 SOT 32	25	36.0	SOT 32							
SK 95 25 2 x M3	25	36.0	2 x M3 (TO 220)							
SK 95 25 1x M2,5 1x M3	25	36.0	1 x M2,5/ 1 x M3 (TO 220)							
SK 95 1000	1000	—	—							
surface:		black anodised								
type of thread:		not anodised								