

Filter Regulator

Series **AW10 to 60**

Integrated filter and regulator units save space and require less piping.

Features

- ▶ Port size M5 - 1".
- ▶ Part of new modular FRL system.
- ▶ Quick release bowl guard on some sizes.
- ▶ Choice of manual or automatic condensate drain.
- ▶ 5µm filter element.
- ▶ Built in gauge available.
- ▶ Locking handle as standard.
- ▶ Tamper proof cap as option.

Symbol

Direct operated, relieving type

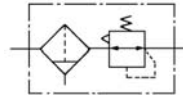

Standard Specifications

Model	AW10	AW20	AW30	AW40	AW40-06	AW60
Port sizes	M5	1/8, 1/4	1/4, 3/8	1/4, 3/8, 1/2	3/4	3/4, 1
Fluid	Air					
Proof pressure	1.5MPa					
Maximum operating pressure	1.0MPa					
Set pressure range	0.05 to 0.85MPa					
Pressure gauge port size ^{Note 1)}	G1/16 ^{Note 2)}	G 1/8	G 1/8	G 1/4	G 1/4	G 1/4
Relief pressure	Set pressure + 0.05MPa ^{Note 3)} [at relief flow rate of 0.1L/min (ANR)]					
Rated Flow	150	800	1500	3000	4000	10000
Ambient and fluid temperature	-5 to 60°C (with no freezing)					
Nominal filtration rating	5 µm					
Drain capacity (cm ³)	2.5	8	25	45	45	45
Bowl material	Polycarbonate					
Bowl guard	—	Option	Standard			
Construction	Relieving type					
Weight (kg)	0.09	0.32	0.40	0.72	0.75	2.0

Note 1) Pressure gauge connection threads are not required for regulators with a square embedded type pressure gauge (AW20 to AW40).

Note 2) Use a bushing (part no: 131368) when connecting R 1/8 pressure gauge to R 1/16 gauge port.

Note 3) Not applicable to AW10.

⊙: Combination available

○: Varies depending on the model

■: Combination not available

Accessory/Optional specification combinations

Accessory/Optional specifications	Combination	Symbol	Accessory					Applicable filter regulator		
			B	C	D	E	G	AW10	AW20	AW30 to 60
With bracket (with neck nut)	B	■	⊙	○	○	○	⊙	⊙	⊙	
Float type auto drain (N.C.)	C	⊙	■	■	■	■	⊙	⊙	⊙	
Float type auto drain (N.O.)	D	⊙	■	■	■	■	■	■	⊙	
Square embedded type pressure gauge	E	⊙	⊙	⊙	■	■	■	⊙	⊙	
Round pressure gauge	G	⊙	⊙	○	■	■	⊙	⊙	⊙	

How to order

AW 30 - F 03 BE

Filter regulator

Body size

10 20 30 40 60

Thread type

Nil* Metric thread (M5)
F G

*only 10 series

Port size

Symbol	Port size	Body size				
		10	20	30	40	60
M5	M5	●	—	—	—	—
01	1/8	—	●	—	—	—
02	1/4	—	●	●	—	—
03	3/8	—	—	●	●	—
04	1/2	—	—	—	●	●
06	3/4	—	—	—	●	●
10	1	—	—	—	—	●

Accessories ^{Note 1)}

Symbol	Description	Applicable model
Nil	—	—
B	With bracket	AW10 to 60
C	Float type auto drain (N.C.)	AW10 to 60
D	Float type auto drain (N.O.)	AW30, 60
E	With square embedded type pressure gauge (with limit indicator)	AW20 to 60
G	With round pressure gauge (without limit indicator)	AW10
	With round pressure gauge (with limit indicator)	AW20 to 60

Note 1) Optional parts are not assembled and are supplied loose at the time of shipment (except for options C, D and E).

Accessory part no.

Applicable model		AW10	AW20	AW30	AW40	AW40-06	AW60	
Accessory								
Bracket assembly ^{Note 1)}		AR10P-270AS	AW20P-270AS	AR30P-270AS	AR40P-270AS	AR40P-270AS	AR60P-270AS	
Neck nut		AR10P-260S	AR20P-260S	AR30P-260S	AR40P-260S	AR40P-260S	-	
Pressure gauge	1.0MPa	Round	G27-10-R1	G36-10-□01	G36-10-□01	G46-10-□02	G46-10-□02	
		Square embedded type ^{Note 3)}	—	GC3-10AS	GC3-10AS	GC3-10AS	GC3-10AS	GC3-10AS
	0.2MPa	Round	G27-10-R1 ^{Note 2)}	G36-2-□01	G36-2-□01	G46-2-□02	G46-2-□02	G46-2-□02
		Square embedded type ^{Note 3)}	—	GC3-2AS	GC3-2AS	GC3-2AS	GC3-2AS	GC3-2AS
Float type auto drain ^{Note 4)} Bowl ass'y	N.O.	—	—	AD38	AD48	AD48	AD48	
	N.C.	AD17	AD27	AD37	AD47	AD47	AD47	

Note 1) Assembly includes a bracket and set nuts.
 Note 2) For 1MPa.
 Note 3) Includes one O-ring and 2 mounting screws.
 Note 4) Minimum operating pressure: N.O. type-0.1MPa; N.C. type-0.1MPa (AD17/27) and 0.15MPa (AD37/47). Contact SMC regarding the specifications for PSI unit and F.

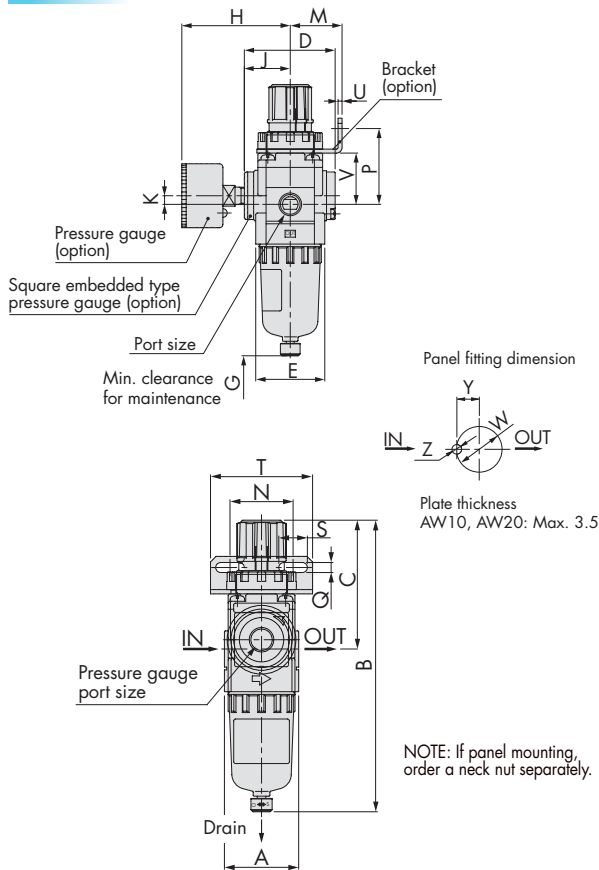
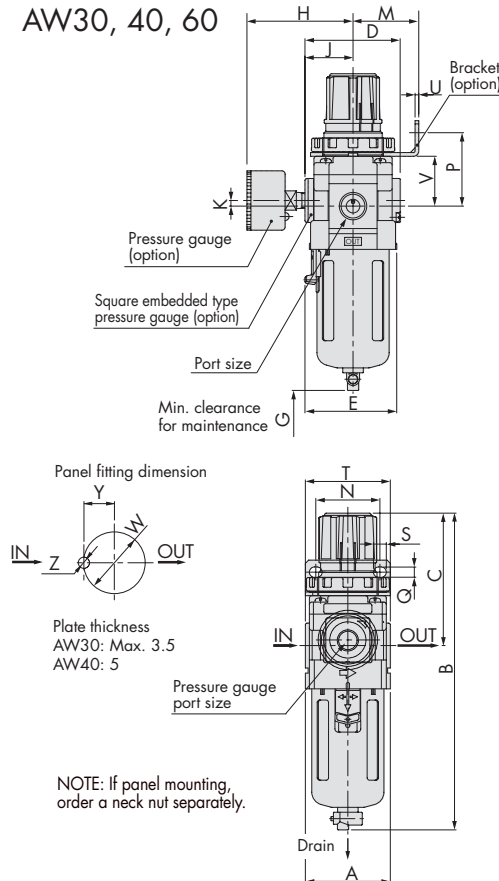
Dimensions AW10, 20

AW30, 40, 60

Model	Port size	Standard specification						Accessory specification														
		A	B	C	D	E	G	With pressure gauge			Bracket mounting size					Panel mount					With auto drain	
								H	J	K	M	N	P	Q	S	T	U	V	W	Y	Z	B
AW10	M5	25	108	48	25	28	25	26	—	0	25	28	30	4.5	6.5	40	2	18	18.5	—	—	125
AW20	1/8, 1/4	40	160	73	52	40	40	63	27	5	30	34	44	5.4	15.4	55	2.3	30	28.5	14	6	177
AW30	1/4, 3/8	53	201	86	59	57	55	66	30.5	3.5	41	40	46	6.5	8	53	2.3	31	38.5	19	7	242
AW40	1/4, 3/8, 1/2	70	239	92	75	73	80	76	38.5	1.5	50	54	54	8.5	10.5	70	2.3	35.5	42.5	21	7	278
AW40-06	3/4	75	242	93	75	73	80	76	38.5	1.2	50	54	56	8.5	10.5	70	2.3	37	42.5	21	7	278
AW60	3/4, 1	95	405	175	95	95	80	84	43.5	3.3	70	66	66	11	13	90	3.2	-	-	-	-	445

Replacement parts

Applicable Model	AW10	AW20	AW30
Spares Kit	KT-AW10	KT-AW20-02	KT-AW30-03
Applicable Model	AW40-04	AL40-06	AW60
Spares Kit	KT-AW40-04	KT-AW40-06	KT-AW60-10

Spares kit includes valve assembly, diaphragm assembly and filter element

