



soberton inc.

SP DYNAMIC SPEAKER UNIT

Acoustic Product Specification

Product Number: SP-1303L

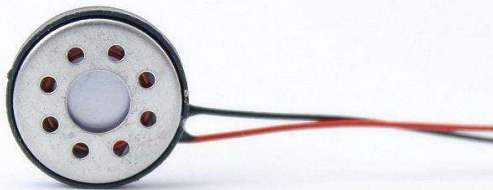

Release | Revision: B/2018

CONTENTS

This document contains the technical specifications for the dynamic speaker unit.

Page 1

Speaker Electroacoustic Characteristics

General Specifications

Page 2

Reliability Tests

Page 3

Measuring Method (Speaker

Dynamic Speaker Electroacoustic C

Sound Pressure Level

87±3dB SPL @1.0, 1.2,1.5 and 2.0KHz in average
Measuring Condition: 0.1W (Sine wave) 10cm r
in Fig.1.

Frequency Response Curve

As shown in Figure 2

Response Frequency

1100±20%Hz @ 1V. (Without Baffler)

Input Power (Nominal and Maximum)

Rated Noise Power 0.5W

Short Term Max Power: 0.8W must be normal a
(1W, F0 ~ 20KHz) for one minute

Operation Test

Must be free audible noise (buzzes and rattles)

(300 ~ 8KHz frequency range, input level up to

Distortion

Less than 10% @1KHz, 0.1M, 0.1W frequency ra

General Specifications

Operating Temperature Range

-20°C~+60°C

Storage Temperature Range

-30°C~+70°C

Standard Test Conditions

Temperature 17°C~25°C



soberton inc.

SP DYNAMIC SPEAKER UNIT

Acoustic Product Specification

Product Number: SP-1303L

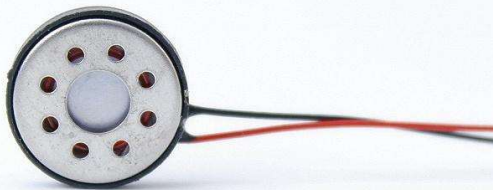

Release | Revision: B/2018

CONTENTS

This document contains the technical specifications for the dynamic speaker unit.

Page 1

Speaker Electroacoustic Characteristics

General Specifications

Page 2

Reliability Tests

Page 3

Measuring Method (Speaker

Reliability Tests

The sound pressure as specified will neither deviate more than the specified value, nor have any significant damage after any of following tests.

High Temperature Test

High Temperature $+60\pm 2^{\circ}\text{C}$

Duration 96 hours

Low Temperature Test

Low Temperature $-20\pm 2^{\circ}\text{C}$

Duration 96 hours

Heat Shock Test

High Temperature $+60\pm 2^{\circ}\text{C}$

Low Temperature $-20\pm 2^{\circ}\text{C}$

Changeover Time <30 seconds

Duration 1 hour

Cycle 100

Humidity Test

Temperature $+40\pm 2^{\circ}\text{C}$

Relative Humidity 90%~95%

Duration 96 hours

Temperature Cycle Test

Temperature -20°C $+60^{\circ}\text{C}$

Duration 45 minutes 45 minutes

Temperature gradient $1\sim 3^{\circ}\text{C}/\text{min}$

Cycle 25

Drop Test

Mounted with dummy set mass 100 g



soberton inc.

SP DYNAMIC SPEAKER UNIT

Acoustic Product Specification

Product Number: SP-1303L

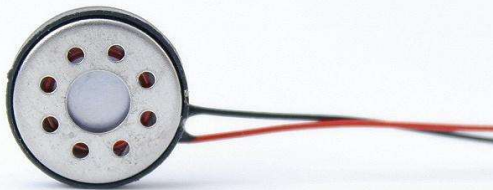

Release | Revision: B/2018

CONTENTS

This document contains the technical specifications for the dynamic speaker unit.

Page 1

Speaker Electroacoustic Characteristics

General Specifications

Page 2

Reliability Tests

Page 3

Measuring Method (Speaker

Measuring Method (Speaker

Standard Test Condition

Temperature 15 ~ 35°C

Relative humidity 45% ~ 85%

Atmospheric pressure 860mbar to 1060

Standard Test Fixture

Input Power 0.1W

Zero Level -dB

Mode TSR

Potentiometer Range 50dB

Sweep Time 0.5sec

Standard Test Condition of Spea

Standard test condition of sp

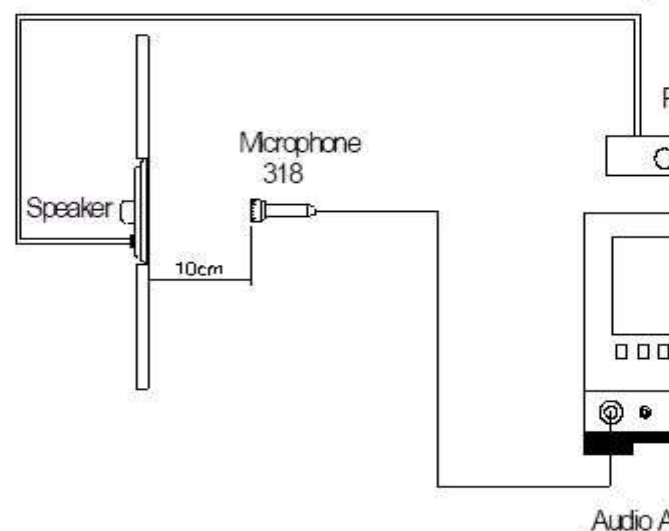



soberton inc.

SP DYNAMIC SPEAKER UNIT

Acoustic Product Specification

Product Number: SP-1303L

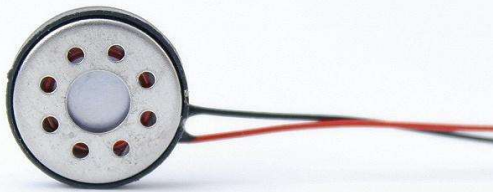

Release | Revision: B/2018

CONTENTS

This document contains the technical specifications for the dynamic speaker unit.

Page 1

Speaker Electroacoustic Characteristics

General Specifications

Page 2

Reliability Tests

Page 3

Measuring Method (Speaker

Frequency Response Curve

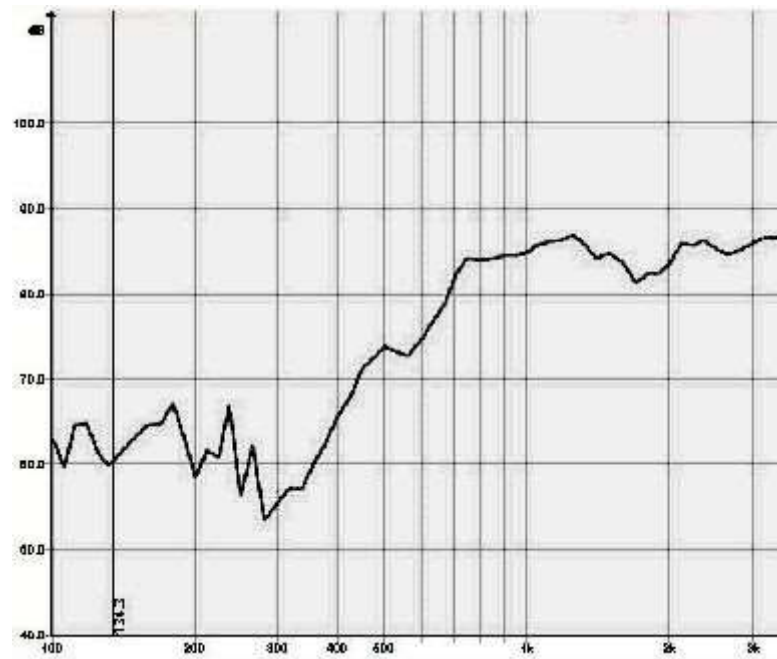



soberton inc.

SP DYNAMIC SPEAKER UNIT

Acoustic Product Specification

Product Number: SP-1303L

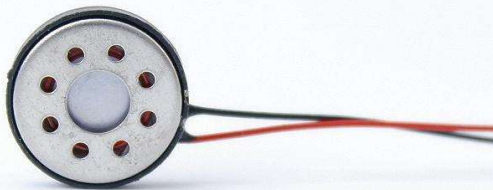

Release | Revision: B/2018

CONTENTS

This document contains the technical specifications for the dynamic speaker unit.

Page 1

Speaker Electroacoustic Characteristics

General Specifications

Page 2

Reliability Tests

Page 3

Measuring Method (Speaker

Dimensions

Tolerance: ± 0.5 (unit: mm)

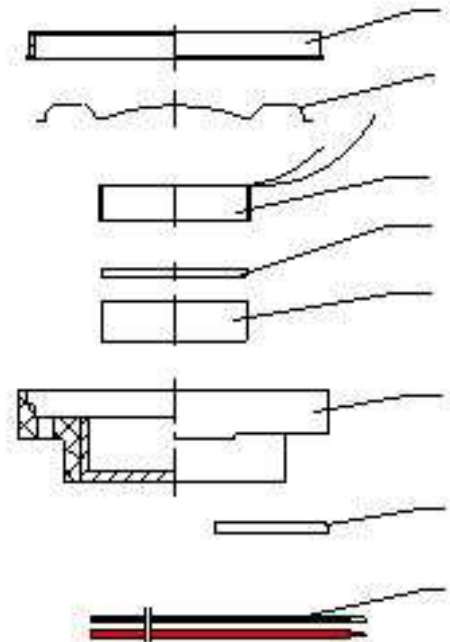
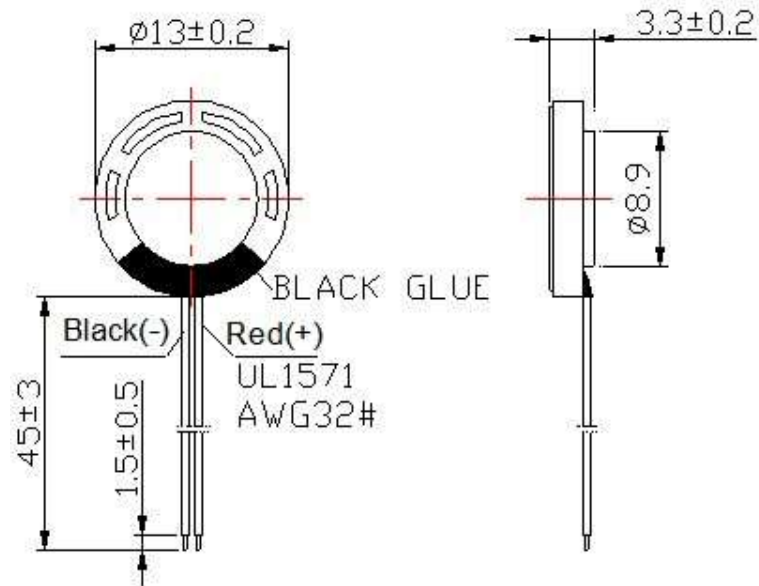

No.	Part Name	Material
1	Wire	UL1571 AWG32#
2	PCB	FR-4



soberton inc.

SP DYNAMIC SPEAKER UNIT

Acoustic Product Specification

Product Number: SP-1303L

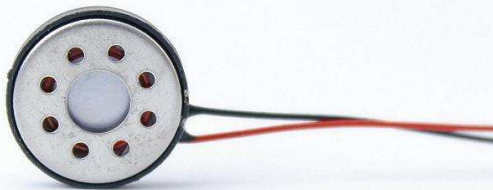

Release | Revision: B/2018

CONTENTS

This document contains the technical specifications for the dynamic speaker unit.

Page 1

Speaker Electroacoustic Characteristics

General Specifications

Page 2

Reliability Tests

Page 3

Measuring Method (Speaker

Packing

