

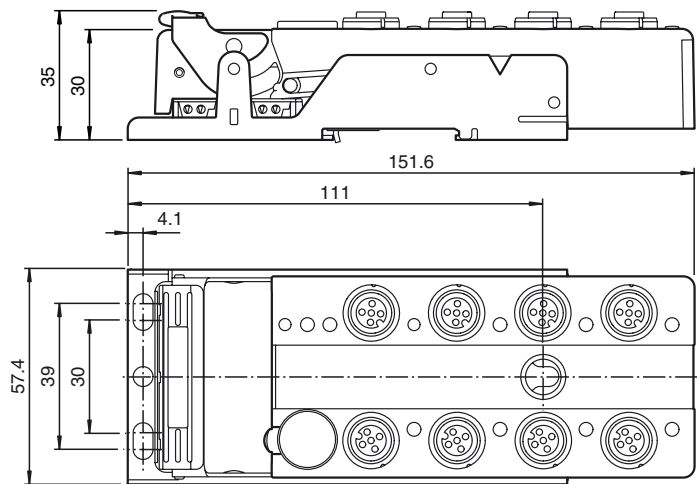

Dimensions

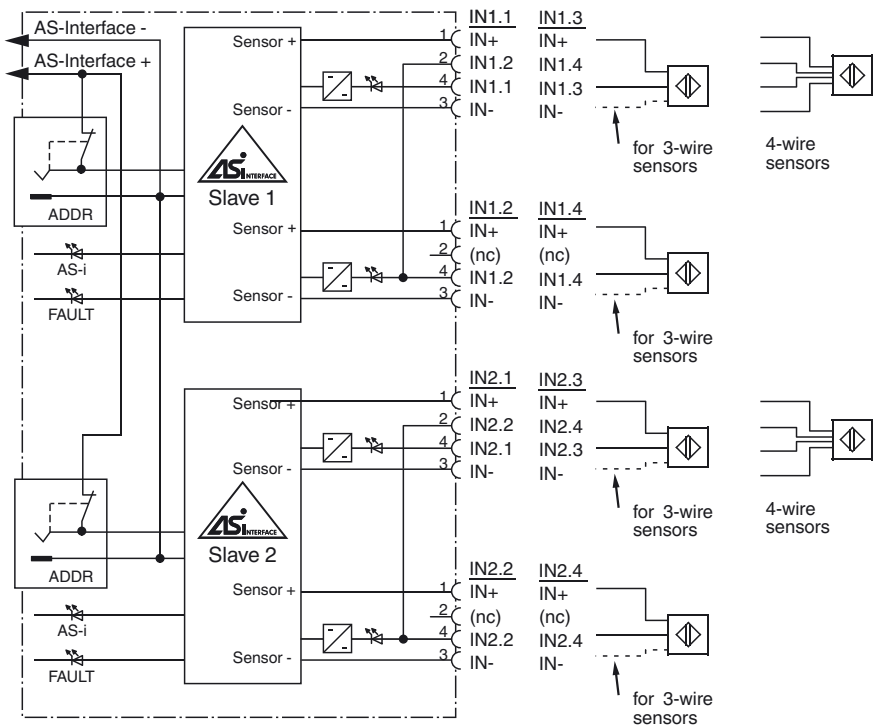

Electrical connection



Model number

VBA-4E4E-G12-ZAJ

G12 flat module
2 x 4 inputs (PNP)

Features

- A/B slave with extended addressing possibility for up to 62 slaves
- One-piece housing with stainless steel base
- Installation without tools
- Metal threaded inserts with SPEED-CON technology
- Flat cable connection with cable piercing technique, variable flat cable guide
- Communication monitoring, configurable
- Inputs for 2-, 3-, and 4-wire sensors
- DIN rail mounting
- AS-Interface certificate
- Automatic addressing with latest masters in the event of replacement

Indicating / Operating means

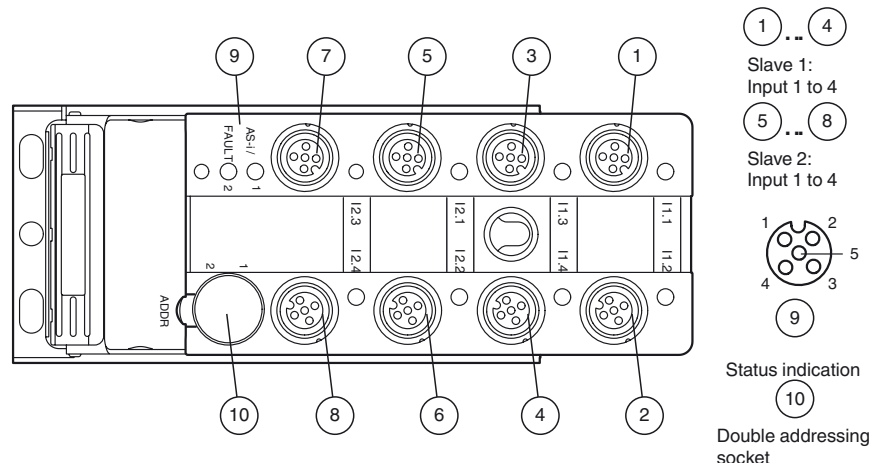

Release date: 2013-12-12 13:59 Date of issue: 2015-02-05 200524_eng.xml

Technical data**General specifications**

Slave type	Double A/B slave
AS-Interface specification	V3.0
Required master specification	≥ V2.1
UL File Number	E87056

Functional safety related parameters

MTTF _d	60 a
Mission Time (T _M)	20 a
Diagnostic Coverage (DC)	0 %

Indicators/operating means

LED PWR/FAULT	2 Dual LEDs green/red green: AS-Interface voltage red: Communication error yellow/red flashing: Address 0 green/red flashing: Sensor supply overload
LED IN	switching state (input); 8 LED yellow

Electrical specifications

Rated operating voltage	U _e	26.5 ... 31.6 V from AS-Interface
Rated operating current	I _e	≤ 80 mA (without sensors) / max. 280 mA
Protection class		III

Input

Number/Type	2x 4 inputs for 2- or 3-wire sensors (PNP), DC alternative 2x 2 inputs for 4-wire sensors (PNP), DC
Supply	from AS-Interface
Voltage	21 ... 31 V
Current loading capacity	≤ 200 mA, overload and short-circuit protected
Input current	≤ 8 mA (limited internally)
Switching point	according to DIN EN 61131-2 (Type 2)
0 (unattenuated)	≤ 2 mA
1 (attenuated)	≥ 6 mA
Signal delay	< 1 ms (input/AS-Interface)

Programming instructions

Profile	S-0.A.2
IO code	0
ID code	A
ID1 code	Slave 1 Slave 2 1 2
ID2 code	2

Data bits (function via AS-Interface) **Input slave 1 input slave 2**

D0	IN1.1	IN2.1
D1	IN1.2	IN2.2
D2	IN1.3	IN2.3
D3	IN1.4	IN2.4

Parameter bits (programmable via AS-i) **function**

P0	not used
P1	Input filter P1 = 0 input filter on, pulse suppression ≤ 2 ms P1 = 1 input filter off (basic setting)
P2	Synchronous mode P2 = 0 synchronous mode on P2 = 1 synchronous mode off (basic setting)
P3	not used

Ambient conditions

Ambient temperature	-25 ... 70 °C (-13 ... 158 °F)
Storage temperature	-25 ... 85 °C (-13 ... 185 °F)
Shock and impact resistance	30 g, 11 ms in 6 spatial directions 3 shocks 10 g, 16 ms in 6 spatial directions 1000 shocks
Vibration resistance	0.75 mm 10 ... 57 Hz, 5 g 57 ... 150 Hz, 20 cycles

Mechanical specifications

Degree of protection	IP67
Connection	cable piercing method flat cable yellow inputs: M12 round connector

Material

Housing	PBT
Mass	230 g
Mounting	Mounting base

Compliance with standards and directives

Directive conformity	
EMC Directive 2004/108/EC	EN 61000-6-2:2005, EN 61000-6-4:2007, EN 50295:1999
Standard conformity	
Noise immunity	EN 61000-6-2:2005, EN 50295:1999
Emitted interference	EN 61000-6-4:2007
Input	EN 61131-2
Degree of protection	EN 60529

Function

The VBA-4E4E-G12-ZAJ is an AS-Interface input module with 8 inputs. The input module is equipped with 2 separate AS-Interface chips and uses 2 A/B addresses. In the delivered state, both slave addresses use the address 0. The second slave is deactivated until the first slave is addressed. Duplicate addressing is avoided in this way. 2 and 3-wire sensors can also be connected as mechanical contacts to the PNP electronic inputs.

The one-piece enclosure makes fast mounting possible completely without the use of tools as well as easy removal also without the use of tools. The stainless steel half shell and cast enclosure ensure maximum durability and a high degree of protection.

Connection to the AS-Interface line is achieved through insulation-piercing technology into the laid flat cable. Accordingly, the flat cable can be turned in two directions for the application.

Metal inserts ensure that all connections to the inputs are made with a high degree of stability. The connections to the sensors are made via an M12 x 1 round plug connector with the option with SPEEDCON technology. The supply to the inputs and the connected sensors is fed from the internal supply of the module (from AS-Interface).

An LED, which is attached to the top of the module, is available to display the current switching state of every input.

A dual LED to indicate the particular AS-Interface voltage and the display, which has the module address 0, is available, and another dual LED indicates errors in the relevant AS-Interface communication and peripheral errors. The input module has a dual addressing jack.

This module can be mounted in any position with three screws or snapped onto a standard DIN rail with the stainless steel bracket.

Accessories**VBP-HH1-V3.0-KIT**

AS-Interface Handheld with accessory

VAZ-V1-B3

Blind plug for M12 sockets

VBP-HH1-V3.0

AS-Interface Handheld

VAZ-PK-1,5M-V1-G

Adapter cable module/hand-held programming device

VAZ-CLIP-G12

lock for G12 module

Fieldbus standard

EN 50295, IEC 62026-2

Notes

For 4-wire sensors, it is only possible to use plug-in slot IN1 or IN3 for inputs 1+2 or 3+4 (jumped internally).

Do not connect inputs and outputs, which are supplied via the module from AS-interface or via auxiliary power, with power supply and signal circuits with external potentials.

Release date: 2013-12-12 13:59 Date of issue: 2015-02-05 200524_eng.xml

Refer to "General Notes Relating to Pepperl+Fuchs Product Information".

Pepperl+Fuchs Group
www.pepperl-fuchs.com

USA: +1 330 486 0001
fa-info@us.pepperl-fuchs.com

Germany: +49 621 776 4411
fa-info@de.pepperl-fuchs.com

Singapore: +65 6779 9091
fa-info@sg.pepperl-fuchs.com