

Sprockets with One-Sided Hub, ISO 16 B-1

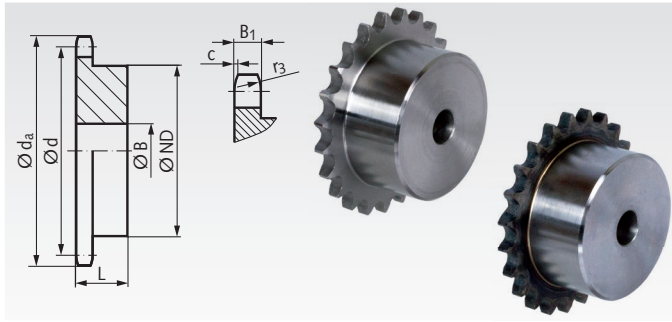

Material: Steel C45, optionally hardened.
Pre-bored. Sprockets marked with * from grey cast iron GG25.

Type KRS: Not hardened.

Type KRG: Teeth induction hardened (approx. HRC 50).

Ordering Details: e.g.: Product No. 10810800, KRS, ISO 16 B-1, 8 Teeth

ISO 16 B-1, Pitch 1" x 17.02 mm

$B_1 = 16.2$ mm, $c = 2.5$ mm, $r_3 = 26$ mm

Product No. Type KRS	Product No. Type KRG	Number of teeth	d_a mm	d mm	ND mm	B mm	L mm	Weight kg
108 108 00	108 881 08	8	77,0	66,37	42	16	35	0,50
108 109 00	108 881 09	9	85,0	74,26	50	16	35	0,69
108 110 00	108 881 10	10	93,0	82,19	55	16	35	0,87
108 111 00	108 881 11	11	99,5	90,14	61	16	40	1,18
108 112 00	108 881 12	12	109,0	98,14	69	16	40	1,46
108 113 00	108 881 13	13	117,0	106,12	78	16	40	1,81
108 114 00	108 881 14	14	125,0	114,15	84	16	40	2,10
108 115 00	108 881 15	15	133,0	122,17	92	16	40	2,49
108 116 00	108 881 16	16	141,0	130,20	100	20	45	3,19
108 117 00	108 881 17	17	149,0	138,22	100	20	45	3,36
108 118 00	108 881 18	18	157,0	146,28	100	20	45	3,61
108 119 00	108 881 19	19	165,2	154,33	100	20	45	3,82
108 120 00	108 881 20	20	173,2	162,38	100	20	45	4,07
108 121 00	108 881 21	21	181,2	170,43	110	20	50	5,03
108 122 00	108 881 22	22	189,3	178,48	110	20	50	5,36
108 123 00	108 881 23	23	197,5	186,53	110	20	50	5,59
108 124 00	108 881 24	24	205,5	194,59	110	20	50	5,92
108 125 00	108 881 25	25	213,5	202,66	110	20	50	6,21
108 126 00	108 881 26	26	221,6	210,72	120	20	50	7,02
108 127 00	108 881 27	27	229,6	218,79	120	20	50	7,27
108 128 00	108 881 28	28	237,7	226,85	120	20	50	7,68
108 130 00	108 881 30	30	254,0	243,00	120	20	50	8,42
108 132 00	108 881 32	32	270,0	259,13	120	25	50	9,25
108 134 00	108 881 34	34	287,0	275,28	120	25	50	9,93
108 135 00	108 881 35	35	296,2	283,36	120	25	50	10,47
108 136 00	108 881 36	36	304,6	291,44	120	25	50	10,95
108 138 00	108 881 38	38	320,7	307,59	120	25	50	11,71
-	108 881 40	40	336,9	323,74	120	25	50	14,05
108 145 00*	-	45	377,0	364,13	125	30	70	10,91
108 157 00*	-	57	474,0	461,08	125	35	70	13,79
108 176 00*	-	76	627,0	614,65	140	35	80	26,50
108 183 00*	-	95	781,0	768,22	140	40	80	35,00
108 188 00*	-	114	934,3	921,81	140	40	80	43,50



Sprockets marked with * are made from grey cast iron GG25.

Sprockets made from stainless steel page 73.
Sprockets ready-to-mount page 86.
Sprockets for Taper clamping bushes page 92.

Plate wheels KRL, ISO 16 B-1

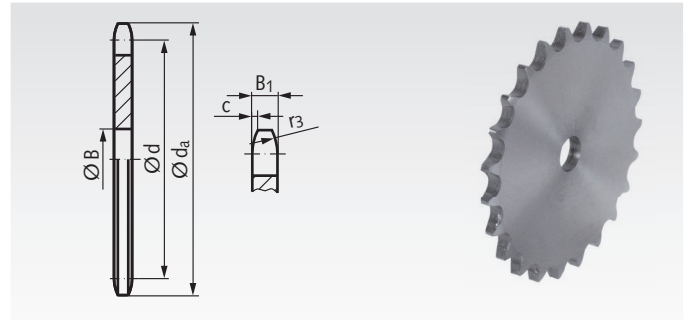

Material: Low-carbon steel, not hardable.
Pre-bored.

Ordering Details: e.g.: Product No. 10820800, KRL, ISO 16 B-1, 8 Teeth

ISO 16 B-1, Pitch 1" x 17.02 mm

$B_1 = 16.2$ mm, $c = 2.5$ mm, $r_3 = 26$ mm

Product No. Type KRL	Number of teeth	d_a mm	d mm	B mm	Weight kg
108 208 00	8	77,0	66,37	16	0,31
108 209 00	9	85,0	74,26	16	0,38
108 210 00	10	93,0	82,19	16	0,53
108 211 00	11	99,5	90,14	16	0,62
108 212 00	12	109,0	98,14	16	0,78
108 213 00	13	117,0	106,12	16	0,94
108 214 00	14	125,0	114,15	16	1,09
108 215 00	15	133,0	122,17	16	1,26
108 216 00	16	141,0	130,20	20	1,41
108 217 00	17	149,0	138,22	20	1,62
108 218 00	18	157,0	146,28	20	1,85
108 219 00	19	165,2	154,33	20	2,04
108 220 00	20	173,2	162,38	20	2,30
108 221 00	21	181,2	170,43	20	2,59
108 222 00	22	189,3	178,48	20	2,84
108 223 00	23	197,5	186,53	20	3,12
108 224 00	24	205,5	194,59	20	3,37
108 225 00	25	213,5	202,66	20	3,92
108 226 00	26	221,6	210,72	20	4,13
108 227 00	27	229,6	218,79	20	4,34
108 228 00	28	237,7	226,85	20	4,67
108 230 00	30	254,0	243,00	20	5,43
108 232 00	32	270,0	259,13	25	6,35
108 234 00	34	287,0	275,28	25	6,97
108 235 00	35	296,2	283,36	25	7,39
108 236 00	36	304,6	291,44	25	7,75
108 238 00	38	320,7	307,59	25	8,68
108 240 00	40	336,9	323,74	25	9,88
108 242 00	42	353,0	339,89	25	10,92
108 243 00	43	359,1	347,97	25	11,46
108 244 00	44	369,1	356,06	25	12,00
108 245 00	45	377,1	364,13	25	12,40
108 248 00	48	401,3	388,36	25	14,00
108 250 00	50	417,4	404,52	25	15,60
108 254 00	54	448,3	436,85	30	18,00
108 257 00	57	474,0	461,07	30	20,00
108 260 00	60	498,3	485,32	30	22,00
108 270 00	70	579,2	566,14	30	31,00
108 276 00	76	627,0	614,65	30	35,00
108 280 00	80	660,0	646,96	30	40,50
108 283 00	95	781,1	768,22	30	56,00
108 288 00	114	934,3	921,81	30	80,00

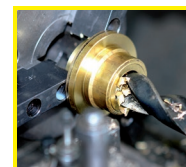

**Reworking within
24h-service possible.
Custom made parts
on request.**