

Date Issued :	August 02, 2022	PCN Number :	512406
Reason for Change :	Capacity change or tool replacement		
Description of Change :	This notification is to inform you about set of tooling is being added to meet the current and future demands of this product referenced below. There will be no changes in fit, form or function from additional tooling when compared to the existing tooling		
Reason for Short Notice :	Capacity Increase		
Assessment of Change :	Dimension analysis		
Planned Implementation Date :	December 05, 2022		
Sample Availability Date:	November 20, 2022		
Internal Molex Qualification Date :	November 20, 2022		
Last date to request Samples by Customer :	October 31, 2022		
Traceability Code Markings / Date :	Cavity identification		

Before Picture

■ Impacted Products Pictures

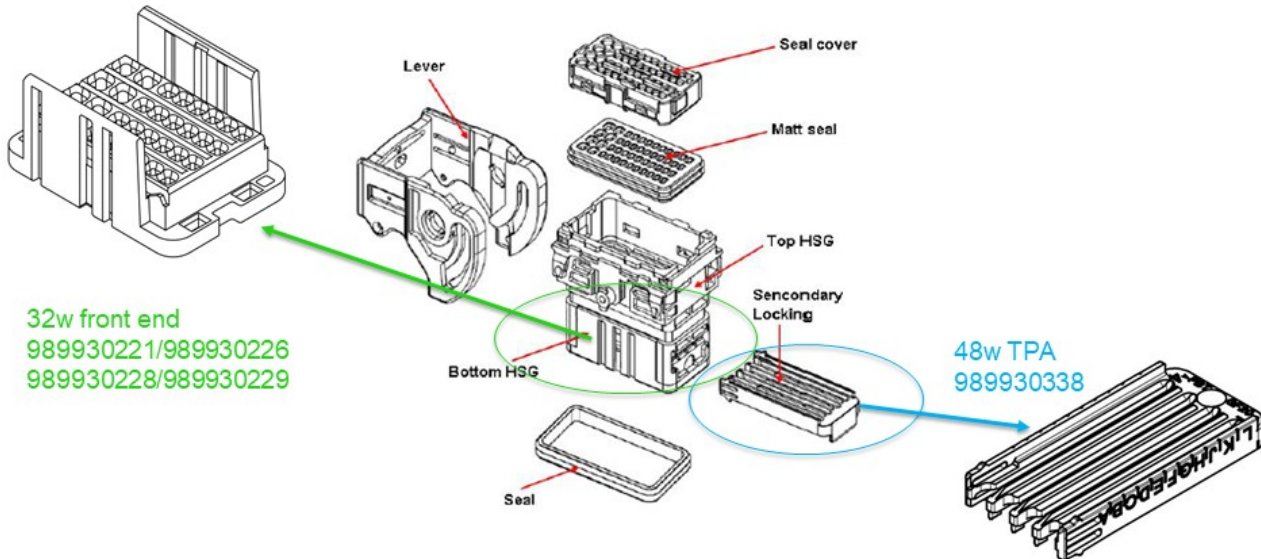

After Picture

Overview

- Due to increase in product, we are experiencing extremely high demand beyond our capacity to respond within lead time. Molex is expediting capacity component tooling to increase output.
- These part numbers are Molex proprietary designs, therefore considered catalog/general market product

- Product Impact
 - no impact to fit, form or function

- Part Number Impact
 - see attached impacted parts list

- PPAP will be available upon request beginning 23-Nov-2022. Request for PPAP must occur by 23-Nov-2022. Submissions must will not occur without request.
 - If PPAP requested, disposition response required within 5 days of submit date or it will be considered approved.
 - If no PPAP requested by 23-Nov-2022, the PPAP will be considered approved.

RELEASED

You may address inquires regarding this PCN by clicking on the below link
mailto:pcn_coordinator@molex.com?subject=PCN_Notification:512406
or contact your Local Sales Engineer.

Note: While responding, please retain " PCN Notification : **PCN Notification: 512406** " in the e-mail Subject line for faster response.

[Molex, LLC](#)
2222 Wellington Court
Lisle, IL 60532
TEL (800) 786-6539
www.molex.com