

AXOR

DE / Gebrauchsanleitung / Montageanleitung	02
FR / Mode d'emploi / Instructions de montage	03
EN / Instructions for use / assembly instructions	04
IT / Istruzioni per l'uso / Istruzioni per l'installazione	05
ES / Modo de empleo / Instrucciones de montaje	06
NL / Gebruiksaanwijzing / Handleiding	07
DK / Brugsanvisning / Monteringsvejledning	08
PT / Instruções para uso / Manual de Instalação	09
PL / Instrukcja obsługi / Instrukcja montażu	10
CS / Návod k použití / Montážní návod	11
SK / Návod na použitie / Montážny návod	12
ZH / 用户手册 / 组装说明	13
RU / Руководство пользователя / Инструкция по монтажу	14
FI / Käyttöohje / Asennusohje	15
SV / Bruksanvisning / Monteringsanvisning	16
LT / Vartotojo instrukcija / Montavimo instrukcijos	17
HR / Upute za uporabu / Uputstva za instalaciju	18
TR / Kullanım kılavuzu / Montaj kılavuzu	19
RO / Manual de utilizare / Instrucțiuni de montare	20
EL / Οδηγίες χρήσης / Οδηγία συναρμολόγησης	21
SL / Navodilo za uporabo / Navodila za montažo	22
ET / Kasutusjuhend / Paigaldusjuhend	23
LV / Lietošanas pamācība / Montāžas instrukcija	24
SR / Uputstvo za upotrebu / Uputstvo za montažu	25
NO / Bruksanvisning / Montasjeveiledning	26
BG / Инструкция за употреба / Ръководство за монтаж	27
SQ / Udhëzuesi i përdorimit / Udhëzime rreth montimit	28
AR / دليل الاستخدام / تعليمات التجميع	29
HU / Használati útmutató / Szerelési útmutató	30

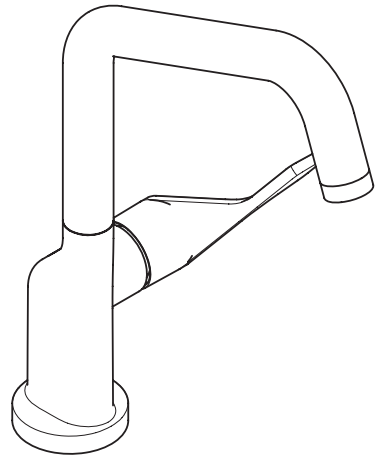

AXOR Citterio
39850XXX

AXOR Citterio Eco
39853000

△ SICHERHEITSHINWEISE

- △ Bei der Montage müssen zur Vermeidung von Quetsch- und Schnittverletzungen Handschuhe getragen werden.
- △ Große Druckunterschiede zwischen den Kalt- und Warmwasseranschlüssen müssen ausgeglichen werden.

MONTAGEHINWEISE

- / Vor der Montage muss das Produkt auf Transportschäden untersucht werden. Nach dem Einbau werden keine Transport- oder Oberflächenschäden anerkannt.
- / Die Leitungen und die Armatur müssen nach den gültigen Normen montiert, gespült und geprüft werden.
- / Die in den Ländern jeweils gültigen Installationsrichtlinien sind einzuhalten.
- / 39853000: Die Armatur kann nicht in Verbindung mit einem Durchlauferhitzer verwendet werden.

TECHNISCHE DATEN

Betriebsdruck:	max. 1 MPa
Empfohlener Betriebsdruck:	0,1 - 0,5 MPa
Prüfdruck:	1,6 MPa
	(1 MPa = 10 bar = 147 PSI)
Heißwassertemperatur:	max. 70°C
Empfohlene Heißwassertemperatur:	65°C
Thermische Desinfektion:	max. 70°C/4 min

Das Produkt ist ausschließlich für Trinkwasser konzipiert!

SYMBOLERKLÄRUNG

Kein essigsäurehaltiges Silikon verwenden!

JUSTIERUNG (siehe Seite 36)

Einstellen der Warmwasserbegrenzung. In Verbindung mit Durchlauferhitzern ist eine Warmwassersperre nicht zu empfehlen.

**MASSE** (siehe Seite 42)**DURCHFLUSSDIAGRAMM**
(siehe Seite 42)**SERVICETEILE** (siehe Seite 44)

XXX = Farbcodierung
000 = Chrom
020 = Polished Chrome
130 = Polished Bronze
140 = Brushed Bronze
250 = Brushed Gold-Optic
260 = Brushed Chrome
300 = Polished Redgold
310 = Brushed Redgold
330 = Polished Black Chrome
340 = Brushed Black Chrome
800 = Stainless Steel Optic
820 = Brushed Nickel
830 = Polished Nickel
930 = Polished Brass
950 = Brushed Brass
990 = Polished Gold-Optic

SONDERZUBEHÖR

(nicht im Lieferumfang enthalten)



Adapter (G $\frac{1}{2}$ /G $\frac{3}{4}$) #93395000
(siehe Seite 45)

**REINIGUNG** (siehe Seite 38)**BEDIENUNG** (siehe Seite 37)

Hansgrohe empfiehlt, morgens oder nach längeren Stagnationszeiten den ersten halben Liter nicht als Trinkwasser zu verwenden.

**PRÜFZEICHEN** (siehe Seite 43)

STÖRUNG	URSACHE	ABHILFE
/ Wenig Wasser	/ Luftsprudler verkalkt, verschmutzt	/ Luftsprudler reinigen/austauschen
/ Armatur schwergängig	/ Kartusche defekt, verkalkt	/ Kartusche austauschen
/ Armatur tropft	/ Kartusche defekt	/ Kartusche austauschen
/ Wasseraustritt am Befestigungsschaft	/ Anschlusschläuche nicht ganz in den Grundkörper eingeschraubt	/ Anschlusschläuche von Hand festziehen
	/ O-Ring am Anschluss Schlauch defekt	/ O-Ring austauschen
/ Zu niedrige Warmwassertemperatur	/ Warmwasserbegrenzung falsch eingestellt	/ Warmwasserbegrenzung einstellen

MONTAGE (siehe Seite 32)

△ CONSIGNES DE SÉCURITÉ

- △ Lors du montage, porter des gants de protection pour éviter toute blessure par écrasement ou coupure.
- △ Il est conseillé d'équilibrer les pressions de l'eau chaude et froide.

INSTRUCTIONS POUR LE MONTAGE

- / Avant son montage, s'assurer que le produit n'a subi aucun dommage pendant le transport. Après le montage, tout dommage de transport ou de surface ne pourra pas être reconnu.
- / Les conduites et la robinetterie doivent être montés, rincés et contrôlés selon les normes en vigueur.
- / Les directives d'installation en vigueur dans le pays concerné doivent être respectées.
- / 39853000: Le robinet ne fonctionne pas avec une production d'eau chaude instantanée.

INFORMATIONS TECHNIQUES

Pression de service autorisée:	max. 1 MPa
Pression de service conseillée:	0,1 - 0,5 MPa
Pression maximum de contrôle:	1,6 MPa (1 MPa = 10 bar = 147 PSI)
Température d'eau chaude:	max. 70°C
Température recommandée:	65°C
Désinfection thermique:	max. 70°C / 4 min

Le produit est exclusivement conçu pour de l'eau potable!

DESCRIPTION DU SYMBOLE



Ne pas utiliser de silicone contenant de l'acide acétique!



ETALONNAGE (voir pages 36)

Réglage de la limitation d'eau chaude. En liaison avec les chauffe-eau, un blocage de l'eau chaude n'est pas recommandable.



DIMENSIONS (voir pages 42)



DIAGRAMME DU DÉBIT
(voir pages 42)



PIÈCES DÉTACHÉES (voir pages 44)

XXX = Couleurs
000 = Chromé
020 = Polished Chrome
130 = Polished Bronze
140 = Brushed Bronze
250 = Brushed Gold-Optic
260 = Brushed Chrome
300 = Polished Redgold
310 = Brushed Redgold
330 = Polished Black Chrome
340 = Brushed Black Chrome
800 = Stainless Steel Optic
820 = Brushed Nickel
830 = Polished Nickel
930 = Polished Brass
950 = Brushed Brass
990 = Polished Gold-Optic

ACCESSOIRES EN OPTION
(ne fait pas partie de la fourniture)



Adaptateur (G $\frac{1}{2}$ / G $\frac{3}{4}$) #93395000
(voir pages 45)



NETTOYAGE (voir pages 38)



INSTRUCTIONS DE SERVICE
(voir pages 37)

Hansgrohe recommande de ne pas utiliser le premier demi-litre le matin ou après une période de stagnation prolongée.



CLASSIFICATION ACOUSTIQUE
ET DÉBIT (voir pages 43)

DYSFONCTIONNEMENT	ORIGINE	SOLUTION
/ Pas assez d'eau	/ aérateur entartré ou encrassé	/ Nettoyer l'aérateur ou le changer éventuellement
/ Dureté de fonctionnement	/ Cartouche défectueuse, entartrée	/ Changer la cartouche
/ Le mitigeur goutte	/ Cartouche défectueuse	/ Changer la cartouche
/ Fuite à la fixation sous le mitigeur	/ Les flexibles de raccordement ne sont pas correctement visser dans le corps.	/ Resserer le flexible à la main.
	/ Joint torique sous les flexible de raccords défectueux	/ Changer le joint torique
/ Température d'eau chaude trop basse, pas d'eau froide	/ Limiteur de température mal positionné	/ Positionner le limiteur de température

MONTAGE (voir pages 32) 

△ SAFETY NOTES

- △ Gloves should be worn during installation to prevent crushing and cutting injuries.
- △ The hot and cold supplies must be of equal pressures.

INSTALLATION INSTRUCTIONS

- / Prior to installation, inspect the product for transport damages. After it has been installed, no transport or surface damage will be honoured.
- / The pipes and the fixture must be installed, flushed and tested as per the applicable standards.
- / The plumbing codes applicable in the respective countries must be observed.
- / 39853000: The mixer can not used together with a continuous flow water heater.

TECHNICAL DATA

Operating pressure:	max. 1 MPa
Recommended operating pressure:	0,1 - 0,5 MPa
Test pressure:	1,6 MPa
	(1 MPa = 10 bar = 147 PSI)
Hot water temperature:	max. 70°C
Recommended hot water temp.:	65°C
Thermal disinfection:	max. 70°C / 4 min

The product is exclusively designed for drinking water!

SYMBOL DESCRIPTION



Do not use silicone containing acetic acid!



ADJUSTMENT (see page 36)

To adjust the hot water limiter. Using a hot water limiter in combination with a continuous flow water heater is not recommended.



DIMENSIONS (see page 42)



FLOW DIAGRAM (see page 42)



SPARE PARTS (see page 44)

XXX = Colors
000 = Chrome Plated
020 = Polished Chrome
130 = Polished Bronze
140 = Brushed Bronze
250 = Brushed Gold-Optic
260 = Brushed Chrome
300 = Polished Redgold
310 = Brushed Redgold
330 = Polished Black Chrome
340 = Brushed Black Chrome
800 = Stainless Steel Optic
820 = Brushed Nickel
830 = Polished Nickel
930 = Polished Brass
950 = Brushed Brass
990 = Polished Gold-Optic

SPECIAL ACCESSORIES

(order as an extra)



Adapter (G $\frac{1}{2}$ / G $\frac{3}{4}$) #93395000 (see page 45)



CLEANING (see page 38)



OPERATION (see page 37)

Hansgrohe recommends not to use as drinking water the first half liter of water drawn in the morning or after a prolonged period of non-use.



TEST CERTIFICATE (see page 43)

FAULT	CAUSE	REMEDY
/ Insufficient water	/ Aerator calcified, dirty	/ Clean aerator, replace as necessary
/ Mixer stiff	/ Cartridge defective, calcified	/ Exchange cartridge
/ Mixer dripping	/ Cartridge defective	/ Exchange cartridge
/ Water escaping at the threaded base	/ connection hoses not completely screwed into basic body	/ Tighten connection hoses by hand
	/ O-ring at the connection hose defective.	/ Exchange O-ring
/ Hot water temperature too low	/ Hot water limiter incorrectly set	/ Set hot water limiter

ASSEMBLY (see page 32)



△ INDICAZIONI SULLA SICUREZZA

- △ Durante il montaggio, per evitare ferite da schiacciamento e da taglio bisogna indossare guanti protettivi.
- △ Attenzione! Compensare le differenze di pressione tra i collegamenti dell'acqua fredda e dell'acqua calda.

ISTRUZIONI PER IL MONTAGGIO

- / Prima del montaggio è necessario controllare che non ci siano stati danni durante il trasporto. Una volta eseguito il montaggio, non verranno riconosciuti eventuali danni di trasporto o delle superfici.
- / Montare, lavare e controllare tubature e rubinetteria rispettando le norme correnti.
- / Vanno rispettate le direttive di installazione nazionali vigenti nel rispettivo paese.
- / 39853000: Il rubinetto non può essere utilizzato insieme ad uno scaldacqua istantaneo.

DATI TECNICI

Pressione d'uso:	max. 1 MPa
Pressione d'uso consigliata:	0,1 - 0,5 MPa
Pressione di prova:	1,6 MPa (1 MPa = 10 bar = 147 PSI)
Temperatura dell'acqua calda:	max. 70°C
Temp. dell'acqua calda consigliata:	65°C
Disinfezione termica:	max. 70°C / 4 min

Il prodotto è concepito esclusivamente per acqua potabile!

DESCRIZIONE SIMBOLO



Non utilizzare silicone contenente acido acetico!

TARATURA (vedi pagg. 36)

Regolazione del limitatore di erogazione d'acqua calda. Un limitatore di erogazione di acqua calda in combinazione con le caldaie istantanee non è consigliabile.

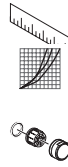

INGOMBRI (vedi pagg. 42)

DIAGRAMMA FLUSSO
(vedi pagg. 42)



PARTI DI RICAMBIO
(vedi pagg. 44)

XXX =	Trattamento
000 =	Cromato
020 =	Polished Chrome
130 =	Polished Bronze
140 =	Brushed Bronze
250 =	Brushed Gold-Optic
260 =	Brushed Chrome
300 =	Polished Redgold
310 =	Brushed Redgold
330 =	Polished Black Chrome
340 =	Brushed Black Chrome
800 =	Stainless Steel Optic
820 =	Brushed Nickel
830 =	Polished Nickel
930 =	Polished Brass
950 =	Brushed Brass
990 =	Polished Gold-Optic

ACCESSORI SPECIALI
(non contenuto nel volume di fornitura)



Adattatore (G $\frac{1}{2}$ /G $\frac{3}{4}$) #93395000
(vedi pagg. 45)



PULITURA (vedi pagg. 38)



PROCEDURA (vedi pagg. 37)

Hansgrohe raccomanda, di mattina oppure dopo lunghi tempi di stagnazione, di non utilizzare il primo mezzo litro come acqua potabile.



SEGNO DI VERIFICA
(vedi pagg. 43)

PROBLEMA	POSSIBILE CAUSA	RIMEDIO
/ Scarsità d'acqua	/ Rompigetto difettoso, pieno di calcare	/ Pulire oppure sostituire il rompigetto
/ Miscelatore duro	/ Cartuccia difettosa	/ Sostituire la cartuccia
/ Miscelatore gocciola	/ Cartuccia difettosa	/ Sostituire la cartuccia
/ Perdita di acqua al set di fissaggio	/ I raccordi dei flessibili avvitati male nel corpo incasso	/ Avvitare i raccordi flessibili a mano
	/ O-ring al raccordo flessibile difettoso	/ Sostituire l'o-ring
/ Temperatura dell'acqua calda	/ Limitazione dell'acqua calda regolata male	/ Regolare la limitazione dell'acqua calda

MONTAGGIO (vedi pagg. 32)



△ INDICACIONES DE SEGURIDAD

- △ Durante el montaje deben utilizarse guantes para evitar heridas por aplastamiento o corte.
- △ Grandes diferencias de presión en servicio entre agua fría y agua caliente deben equilibrarse.

INDICACIONES PARA EL MONTAJE

- / Antes del montaje se debe examinar el producto contra daños de transporte. Después de la instalación no se reconoce ningún daño de transporte o de superficie.
- / Los conductos y la grifería deben montarse, lavarse y comprobarse según las normas vigentes.
- / Es obligatorio el cumplimiento de las directrices de instalación vigentes en el país respectivo.
- / 39853000: Este grifo no es apto en combinación con un calentador continuo.

DATOS TÉCNICOS

Presión en servicio: max. 1 MPa
 Presión recomendada en servicio: 0,1 - 0,5 MPa
 Presión de prueba: 1,6 MPa
 (1 MPa = 10 bar = 147 PSI)
 Temperatura del agua caliente: max. 70°C
 Temp. recomendada del agua caliente: 65°C
 Desinfección térmica: max. 70°C / 4 min

El producto ha sido concebido exclusivamente para agua potable.

DESCRIPCIÓN DE SÍMBOLOS



No utilizar silicona que contiene ácido acético!

AJUSTE (ver página 36)

Ajuste del límite de agua caliente. En combinación con calentadores continuos no es recomendable utilizar un bloqueo de agua caliente.



DIMENSIONES (ver página 42)



DIAGRAMA DE CIRCULACIÓN (ver página 42)



REPUESTOS (ver página 44)

- XXX = Acabados
- 000 = Cromado
- 020 = Polished Chrome
- 130 = Polished Bronze
- 140 = Brushed Bronze
- 250 = Brushed Gold-Optic
- 260 = Brushed Chrome
- 300 = Polished Redgold
- 310 = Brushed Redgold
- 330 = Polished Black Chrome
- 340 = Brushed Black Chrome
- 800 = Stainless Steel Optic
- 820 = Brushed Nickel
- 830 = Polished Nickel
- 930 = Polished Brass
- 950 = Brushed Brass
- 990 = Polished Gold-Optic

O PCIONAL (no incluido en el suministro)



Adaptador (G¹/₂/G³/₄) #93395000 (ver página 45)



LIMPIAR (ver página 38)



MANEJO (ver página 37)

Hansgrohe recomienda no utilizar el primer medio litro como agua potable por las mañanas o tras un largo periodo de inactividad.



MARCA DE VERIFICACIÓN (ver página 43)

PROBLEMA	CAUSA	SOLUCIÓN
/ Sale poca agua	/ Aireador con cal o sucio	/ limpiar/cambiar aireador
/ Manecilla va dura	/ cartucho dañado	/ cambiar el cartucho
/ Grifo pierde agua	/ cartucho dañado	/ cambiar el cartucho
/ Pérdida de agua en el set de fijación	/ Conexión flexible mal atornillada al cuerpo del caño.	/ Apretar a mano la conexión flexible
	/ Daños en la junta de la conexión flexible	/ cambiar juntas
/ Temperatura del agua caliente demasiado baja	/ tope de agua caliente mal	/ ajustar tope



△ VEILIGHEIDSINSTRUCTIES

- △ Bij de montage moeten ter voorkoming van knel- en snijwonden handschoenen worden gedragen.
- △ Grote drukverschillen tussen de koud- en warmwater-toevoer dienen vermeden te worden.

MONTAGE-INSTRUCTIES

- / Vóór de montage moet het product gecontroleerd worden op transportschade. Na de inbouw wordt geen transport- of oppervlakteschade meer aanvaard.
- / De leidingen en armaturen moeten gemonteerd, gespoeld en gecontroleerd worden volgens de geldige normen.
- / De in de overeenkomstige landen geldende installatierichtlijnen moeten nageleefd worden.
- / 39853000: Het artikel kan niet in combinatie met een doorstroomtoestel toegepast worden.

TECHNISCHE GEGEVENS

Werkdruk: max.	max. 1 MPa
Aanbevolen werkdruk:	0,1 - 0,5 MPa
Getest bij:	1,6 MPa
	(1 MPa = 10 bar = 147 PSI)
Temperatuur warm water:	max. 70°C
Aanbevolen warm water temp.:	65°C
Thermische desinfectie:	max. 70°C / 4 min

Het product is uitsluitend ontworpen voor drinkwater!

SYMBOOLBESCHRIJVING



Gebruik geen zuurhoudende siliconel



INSTELLEN (zie blz. 36)

Instellen van de warmwaterbegrenzing. In combinatie met een doorstroomer is een warmwaterblokkering niet aanbevelenswaardig.



MATEN (zie blz. 42)



DOORSTROOMDIAGRAM
(zie blz. 42)



SERVICE ONDERDELEN
(zie blz. 44)

XXX = Kleuren
000 = Verchroomd
020 = Polished Chrome
130 = Polished Bronze
140 = Brushed Bronze
250 = Brushed Gold-Optic
260 = Brushed Chrome
300 = Polished Redgold
310 = Brushed Redgold
330 = Polished Black Chrome
340 = Brushed Black Chrome
800 = Stainless Steel Optic
820 = Brushed Nickel
830 = Polished Nickel
930 = Polished Brass
950 = Brushed Brass
990 = Polished Gold-Optic

TOEBEHOREN

(behoort niet tot het leveringspakket)



Adapter (G½/G¾) #93395000 (zie blz. 45)



REINIGEN (zie blz. 38)



BEDIENING (zie blz. 37)

Hansgrohe raadt aan om 's morgens na langere stagnatietijden de eerste halve liter niet als drinkwater te gebruiken.



KEURMERK (zie blz. 43)

STORING

OORZAAK

OPLOSSING

/ Weinig water	/ Perlator verstopt	/ Perlator reinigen/ uitwisselen
/ Bediening zwaar	/ Kardoes defect of verkalkt	/ Kardoes uitwisselen
/ Mengkraan lekt	/ Kardoes defect	/ Kardoes uitwisselen
/ Lekkage op montageschacht	/ Aansluitslangen niet geheel in kraan- huis vastgedraaid	/ Aansluitslangen handvast aandraaien
	/ O-ring van aansluitslang defect	/ O-ring uitwisselen
/ Temperatuur van warm water te laag	/ Heetwaterbegrenzer verkeerd ingesteld	/ Heetwaterbegrenzer instellen

MONTAGE (zie blz. 32)



△ SIKKERHEDSANVISNINGER

- △ Ved monteringen skal der bruges handsker for at undgå kvæstelser og snitsår.
- △ Større trykforskelle mellem koldt og varmt vand bør udjævnes.

MONTERINGSANVISNINGER

- / Før monteringen skal produktet kontrolleres for transportskader. Efter monteringen godkendes transportskader eller skader på overfladen ikke længere.
- / Ledningerne og armaturerne skal monteres, skylles og kontrolleres iht. de gældende standarder.
- / Installationsbestemmelserne, der gælder i det enkelte land, skal overholdes.
- / 39853000: Armaturet bør ikke anvendes i forbindelse med en gennemstrømningsvandvarmer.

TEKNISKE DATA

Driftstryk:	max. 1 MPa
Anbefalet driftstryk:	0,1 - 0,5 MPa
Prøvetryk:	1,6 MPa
	(1 MPa = 10 bar = 147 PSI)
Varmtvandstemperatur:	max. 70°C
Anbefalet varmtvandstemperatur:	65°C
Termisk desinfektion:	max. 70°C / 4 min
Produktet er udelukkende beregnet til drikkevand!	

SYMBOLBESKRIVELSE



Der må ikke benyttes eddikesyreholdig silikone!

FORINDSTILLING (se s. 36)

Indstilling af varmvandsbegrænsningen. I forbindelse med gennemstrømningsvandvarmere anbefaler vi ikke en varmvandsspærre.



MÅLENE (se s. 42)



GENNEMSTRØMNINGSDIAGRAM (se s. 42)



RESERVEDELE (se s. 44)

XXX = Overflade
000 = Krom
020 = Polished Chrome
130 = Polished Bronze
140 = Brushed Bronze
250 = Brushed Gold-Optic
260 = Brushed Chrome
300 = Polished Redgold
310 = Brushed Redgold
330 = Polished Black Chrome
340 = Brushed Black Chrome
800 = Stainless Steel Optic
820 = Brushed Nickel
830 = Polished Nickel
930 = Polished Brass
950 = Brushed Brass
990 = Polished Gold-Optic

SPECIALTILBEHØR

(ikke med i leveringsomfang)



Adapter (G $\frac{1}{2}$ /G $\frac{3}{4}$) #93395000 (se s. 45)



RENGØRING (se s. 38)



BRUGSANVISNING (se s. 37)

Hansgrohe anbefaler at den første halve liter om morgenen eller efter længere stagneringstider ikke anvendes som drikkevand.



GODKENDELSE (se s. 43)

FEJL	ÅRSAG	HJÆLP
/ For lidt vand	/ Tilkaltet/snavset perlator	/ Rengør/udskift perlator
/ Grebet går trægt	/ Kartusche defekt, tilkaltet	/ Udsift kartusche
/ Armaturet drypper	/ Defekt kartusche	/ Udsift kartusche
/ Armaturet er utæt ved befæstelsesdelene	/ Tilslutningsslangerne er ikke skruet korrekt op i armaturet.	/ Med håndkraft skures tilslutningsslanger strammere på.
	/ Defekt o-ring på tilslutningsslange	/ Udsift o-ring
/ For lav varmtvands-temperatur	/ Varmtvandsbegrænsningen er forkert indstillet	/ Indstil varmtvandsbegrænsningen



△ AVISOS DE SEGURANÇA

- △ Durante a montagem devem ser utilizadas luvas de protecção, de modo a evitar ferimentos resultantes de entalamentos e de cortes.
- △ Grandes diferenças entre as pressões das águas quente e fria devem ser compensadas.

AVISOS DE MONTAGEM

- / Antes da montagem deve-se controlar o produto relativamente a danos de transporte. Após a montagem não são aceites quaisquer danos de transporte ou de superfície.
- / As tubagens e a torneira têm que ser montadas, enxaguadas e verificadas de acordo com as normas em vigor.
- / A prescrições de instalação válidas nos respetivos países devem ser respeitadas.
- / 39853000: A misturadora não pode ser utilizada com esquentadores instantâneos ou caldeira.

DADOS TÉCNICOS

Pressão de funcionamento:	max. 1 MPa
Pressão de func. recomendada:	0,1 - 0,5 MPa
Pressão testada:	1,6 MPa
	(1 MPa = 10 bar = 147 PSI)
Temperatura da água quente:	max. 70°C
Temp. água quente recomendada:	65°C
Desinfecção térmica:	max. 70°C / 4 min

Este produto foi única e exclusivamente concebido para água potável!

DESCRIÇÃO DO SÍMBOLO



Não utilizar silicone que contenha ácido acético!



AFINAÇÃO (ver página 36)

Ajuste do limitador de água quente. Em combinação com um esquentador, não é

recomendável o uso de um bloqueio de água quente.

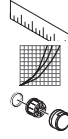

MEDIDAS (ver página 42)

FLUXOGRAMA (ver página 42)

PEÇAS DE SUBSTITUIÇÃO
(ver página 44)

XXX = Acabamentos
000 = Cromado
020 = Polished Chrome
130 = Polished Bronze
140 = Brushed Bronze
250 = Brushed Gold-Optic
260 = Brushed Chrome
300 = Polished Redgold
310 = Brushed Redgold
330 = Polished Black Chrome
340 = Brushed Black Chrome
800 = Stainless Steel Optic
820 = Brushed Nickel
830 = Polished Nickel
930 = Polished Brass
950 = Brushed Brass
990 = Polished Gold-Optic

ACESSÓRIOS ESPECIAIS

(não incluído no volume de fornecimento)



Adaptador (G $\frac{1}{2}$ /G $\frac{3}{4}$) #93395000
(ver página 45)



LIMPEZA (ver página 38)



FUNCIONAMENTO (ver página 37)

A Hansgrohe recomenda a não utilização do primeiro meio litro de água, de manhã ou após longas paragens, para fins de consumo.



MARCA DE CONTROLO
(ver página 43)

FALHA	CAUSA	SOLUÇÃO
/ Água insuficiente	/ Emulsor sujo	/ Limpar/trocar o emulsor
/ Misturadora perra	/ Cartucho defeituoso, calcificado	/ Substituir o cartucho
/ Misturadora a pingar	/ Cartucho defeituoso	/ Substituir o cartucho
/ Perde água pela base roscada	/ Tubos de ligação não estão completamente enroscados	/ Apertar os tubos de ligação à mão
	/ O-ring dos tubo de ligação defeituoso	/ Trocar o-ring
/ Temperatura da água quente muito baixa	/ O limitador de temperatura está incorretamente colocado	/ Regular o limitador de temperatura

MONTAGEM (ver página 32)



Δ WSKAZÓWKI BEZPIECZEŃSTWA

- Δ Aby uniknąć zranień na skutek zgniecenia lub przecięcia, podczas montażu należy nosić rękawice ochronne.
- Δ Znaczne różnice ciśnień na dopływach ciepłej i zimnej wody muszą zostać wyrównane.

WSKAZÓWKI MONTAŻOWE

- / Przed montażem należy skontrolować produkt pod kątem szkód transportowych. Po montażu nie widać żadnych szkód transportowych ani szkód na powierzchni.
- / Przewody i armatura muszą być montowane, płukane i kontrolowane według obowiązujących norm.
- / Należy przestrzegać wytycznych instalacyjnych obowiązujących w danym kraju.
- / 39853000: Armatura nie może współpracować z przepływowymi podgrzewaczami wody.

DANE TECHNICZNE

Ciśnienie robocze:	maks. 1 MPa
Zalecane ciśnienie robocze:	0,1 - 0,5 MPa
Ciśnienie próbne:	1,6 MPa (1 MPa = 10 bary = 147 PSI)
Temperatura wody gorącej:	maks. 70°C
Zalecana temperatura wody gorącej:	65°C
Dezynfekcja termiczna:	maks. 70°C/4 min

Produkt przeznaczony wyłącznie do wody pitnej!

OPIS SYMBOLU



Nie stosować silikonów zawierających kwas octowy!



USTAWIANIE (patrz strona 36)

Ustawianie ogranicznika ciepłej wody.
Używanie ogranicznika temperatury wody w połączeniu z przepływowym podgrzewaczem wody nie jest zalecane.



WYMIARY (patrz strona 42)

SCHEMAT PRZEPŁYWU (patrz strona 42)



CZĘŚCI SERWISOWE (patrz strona 44)

XXX = Kody kolorów
000 = Chrom
020 = Polished Chrome
130 = Polished Bronze
140 = Brushed Bronze
250 = Brushed Gold-Optic
260 = Brushed Chrome
300 = Polished Redgold
310 = Brushed Redgold
330 = Polished Black Chrome
340 = Brushed Black Chrome
800 = Stainless Steel Optic
820 = Brushed Nickel
830 = Polished Nickel
930 = Polished Brass
950 = Brushed Brass
990 = Polished Gold-Optic

WYPOSAŻENIE SPECJALNE
(Nie jest częścią dostawy)



Prześciówka (G $\frac{1}{2}$ /G $\frac{3}{4}$) #93395000
(patrz strona 45)



CZYSZCZENIE (patrz strona 38)



OBŚLUGA (patrz strona 37)

Hansgrohe zaleca, by z rana lub po dłuższym czasie niekorzystania, pierwsze pół litra wody nie używać jako wody pitnej.



ZNAK JAKOŚCI (patrz strona 43)

USTERKA	PRZYCZYNA	POMOC
/ Mała ilość wody	/ Napowietrzacz zakamieniony, zabrudzony	/ Oczyszczyć/wymienić napowietrzacz
/ Uchwyt armatury pracuje z wysiłkiem	/ Uszkodzony wkład, zakamieniony	/ Wymiana wkładu
/ Armatura cieknie	/ Uszkodzony wkład	/ Wymiana wkładu
/ Wyciek wody przy mocowaniu od dołu	/ Zbyt słabo wkręcone wężyki w korpus / Uszkodzony o-ring przy wężu przyłączeniowym	/ Dokręcić wężyki / Wymienić o-ring
/ Za niska temperatura ciepłej wody	/ Niewłaściwe ustawienie ogranicznik ciepłej wody	/ Ustawić ogranicznik ciepłej wody

△ BEZPEČNOSTNÍ POKYNY

- △ Pro zabránění řezným zraněním a pohmožděninám je nutné při montáži nosit rukavice.
- △ Je nutné vyrovnat velké rozdíly tlaku mezi přípoji studené a teplé vody.

POKYNY K MONTÁŽI

- / Před montáží je třeba produkt zkontrolovat, zda nebyl při transportu poškozen. Po zabudování nebudou uznány žádné škody způsobené transportem nebo poškození povrchu.
- / Vedení a armatura musí být namontovány, propláchnuty a otestovány podle platných norem.
- / Je třeba dodržovat montážní pravidla platné v dané zemi.
- / 39853000: Armatura se nesmí používat v kombinaci s průtokovým ohřívačem.

TECHNICKÉ ÚDAJE

Provozní tlak:	max. 1 MPa
Doporučený provozní tlak:	0,1 - 0,5 MPa
Zkušební tlak:	1,6 MPa
	(1 MPa = 10 bar = 147 PSI)
Teplota horké vody:	max. 70°C
Doporučená teplota horké vody:	65°C
Teplná desinfekce:	max. 70°C / 4 min

Výrobky Hansgrohe jsou vhodné pro přímý kontakt s pitnou vodou.

POPIS SYMBOLŮ



Nepoužívat silikon s obsahem kyseliny octové!



NASTAVENÍ (viz strana 36)

Nastavení omezovače teplé vody. Ve spojení s průtokovým ohřívačem se použití uzávěru teplé vody nedoporučuje.



ROZMĚRY (viz strana 42)



DIAGRAM PRŮTOKU (viz strana 42)

SERVISNÍ DÍLY (viz strana 44)

XXX	= Kód povrchové úpravy
000	= Chrom
020	= Polished Chrome
130	= Polished Bronze
140	= Brushed Bronze
250	= Brushed Gold-Optic
260	= Brushed Chrome
300	= Polished Redgold
310	= Brushed Redgold
330	= Polished Black Chrome
340	= Brushed Black Chrome
800	= Stainless Steel Optic
820	= Brushed Nickel
830	= Polished Nickel
930	= Polished Brass
950	= Brushed Brass
990	= Polished Gold-Optic

ZVLÁŠTNÍ PŘÍSLUŠENSTVÍ
(není součástí dodávky)



Adaptér (G¹/₂ / G³/₄) #93395000 (viz strana 45)

ČIŠTĚNÍ (viz strana 38)

OVLÁDÁNÍ (viz strana 37)

Hansgrohe doporučuje ráno nebo po delších přestávkách nepoužívat prvního půl litru jako pitnou vodu.



ZKUŠEBNÍ ZNAČKA (viz strana 43)

PORUCHA	PŘÍČINA	ODSTRANĚNÍ
/ Málo vody	/ perláro zanesen vodním kamenem, znečištěn	/ vyčistit/vyměnit perlátor
/ Armatura jde ztížka	/ Kartuše je vadná, zanesená vodním kamenem	/ Kartuši vyměnit
/ Armatura odkapává	/ Kartuše je vadná	/ Kartuši vyměnit
/ výstup vody na upevňovacím násadci	/ přípojovací hadice nejsou dostatečně zašroubovány do tělesa / O-kroužek na přípojovací hadici je defektní	/ přípojovací hadice utáhnout rukou / vyměnit O-kroužek
/ Nízká teplota teplé vody	/ Špatně nastavená záračka pro teplotu	/ Seřdit záračku pro teplotu vodu

MONTÁŽ (viz strana 32)



△ BEZPEČNOSTNÉ POKYNY

- △ Pri montáži musíte nosiť rukavice, aby ste predišli pomliaždeninám a rezným poraneniam.
- △ Veľké rozdiely v tlaku medzi prípojkami studenej a teplej vody musia byť vyrovnané.

POKYNY PRE MONTÁŽ

- / Pred montážou musíte produkt skontrolovať, či nebol počas transportu poškodený. Po zabudovaní nebudú uznané žiadne škody spôsobené transportom alebo poškodenia povrchu.
- / Ledningarna och blandaren måste monteras, spolás igenom och kontrolleras enligt de gällande normerna.
- / Je potrebné dodržiavať smernice o inštalácii, ktoré sú práve teraz platné v krajinách.
- / 39853000: Armatúra sa nesmie používať v kombinácii s prietokovým ohrievačom.

TECHNICKÉ ÚDAJE

Prevádzkový tlak: max. 1 MPa
 Doporučený prevádzkový tlak: 0,1 - 0,5 MPa
 Skúšobný tlak: 1,6 MPa
 (1 MPa = 10 bar = 147 PSI)

Teplota teplej vody: max. 70°C
 Doporučená teplota teplej vody: 65°C
 Termická dezinfekcia: max. 70°C / 4 min

Výrobok je koncipovaný výhradne pre pitnú vodu!

POPIS SYMBOLOV



Nepoužívať silikón s obsahom kyseliny octovej!



NASTAVENIE (viď strana 36)

Nastavenie obmedzenia teplej vody. V spojení s prietokovými ohrievačmi sa neodporúča použitie obmedzovača teplej vody.



ROZMERY (viď strana 42)



DIAGRAM PRIETOKU

(viď strana 42)



SERVISNÉ DIELY (viď strana 44)

XXX = Farebné označenie
 000 = Chróm
 020 = Polished Chrome
 130 = Polished Bronze
 140 = Brushed Bronze
 250 = Brushed Gold-Optic
 260 = Brushed Chrome
 300 = Polished Redgold
 310 = Brushed Redgold
 330 = Polished Black Chrome
 340 = Brushed Black Chrome
 800 = Stainless Steel Optic
 820 = Brushed Nickel
 830 = Polished Nickel
 930 = Polished Brass
 950 = Brushed Brass
 990 = Polished Gold-Optic

ZVLÁŠTNE PRÍSLUŠENSTVO

(nie je súčasťou dodávky)



Adaptér (G $\frac{1}{2}$ /G $\frac{3}{4}$) #93395000
 (viď strana 45)



ČISTENIE (viď strana 38)



OBSLUHA (viď strana 37)

Hansgrohe odporúča ráno a po dlhších dobách odstavky nepoužiť prvého pol litra vody ako pitnú vodu.



OSVEDČENIE O SKÚŠKE

(viď strana 43)

PORUCHA	PRÍČINA	POMOC
/ Málo vody	/ Perlátor zanesený vodným kameňom	/ Vyčistiť alebo vymeniť perlátor
/ Armatúra "chodí" ťažko	/ Kartuša je poškodená, vápenaté usadeniny	/ Vymeniť kartušu
/ Z armatúry kvapká voda	/ Kartuša je poškodená	/ Vymeniť kartušu
/ Uhajanje vode ob prítldilnem nastavku	/ Hadice pripojenia nie sú celkom zaskrutkované do základného telesa	/ Hadice pripojenia dotiahnuť ručne
	/ Chybný O krúžok na pripojovacej hadici	/ Vymeniť O krúžok
/ Nízka teplota teplej vody	/ Nesprávne nastavená zarážka na teplú vodu	/ Nastavenie zarážky na teplú vodu

MONTÁŽ (viď strana 32)



△ 安全技巧

- △ 装配时为避免挤压和切割受伤，必须戴上手套。
- △ 冷热水管间过大的压力差必须予以平衡。

安装提示

- / 安装前必须检查产品是否受到运输损害。安装后将不认可运输损害或表面损伤。
- / 管道和阀门必须根据通用标准进行安装、冲洗和检查。
- / 请遵守当地国家现行的安装规定。
- / 39853000: 阀门不可与即热式热水器连接使用。

技术参数

工作压力:	最大 1 MPa
推荐工作压力:	0,1 - 0,5 MPa
测试压强:	1,6 MPa (1 MPa = 10 bar = 147 PSI)
热水温度:	最大 70°C
推荐热水温度:	65°C
热力消毒:	最大 70°C / 4 分钟

该产品专为饮用水设计！

符号说明



请勿使用含有乙酸的硅胶！



调节 (参见第页 36)

热水温度调节。如果使用即热式喷头，则不建议安装热水阀门。



大小 (参见第页 42)



流量示意图 (参见第页 42)



备用零件 (参见第页 44)

XXX = 颜色代码

000 = 镀铬

020 = Polished Chrome

130 = Polished Bronze

140 = Brushed Bronze

250 = Brushed Gold-Optic

260 = Brushed Chrome

300 = Polished Redgold

310 = Brushed Redgold

330 = Polished Black Chrome

340 = Brushed Black Chrome

800 = Stainless Steel Optic

820 = Brushed Nickel

830 = Polished Nickel

930 = Polished Brass

950 = Brushed Brass

990 = Polished Gold-Optic

选装附件 (不在供货范围内)



转接器 (G $\frac{1}{2}$ /G $\frac{3}{4}$) #93395000
(参见第页 45)



清洗 (参见第页 38)



操作 (参见第页 37)

汉斯格雅建议，清晨或在水流长时间停滞
后，前半升水不作饮用水使用。



检验标记 (参见第页 43)

问题	原因	补救
/ 龙头出水量小	/ 通风机结垢，脏污	/ 检查通风机，视需要更换
/ 龙头不灵活	/ 阀芯损坏，结垢	/ 更换阀芯
/ 龙头滴水	/ 阀芯损坏	/ 更换阀芯
/ 水从螺纹底座中流出	/ 连接软管没有完全旋入基体	/ 用手拧紧连接软管
	/ 连接软管的O形环损坏	/ 更换O形环
/ 热水温度过低	/ 温度限制器设置错误	/ 设置温度限制器

△ УКАЗАНИЯ ПО ТЕХНИКЕ БЕЗОПАСНОСТИ

- △ Во время монтажа следует надеть перчатки во избежание прищемления и порезов.
- △ донного клапа. Перед установкой смесителя необходимо регулировочными кранами выровнять давление холодной и горячей воды при помощи вентилей регулирующих подачу воды в квартиру.

УКАЗАНИЯ ПО МОНТАЖУ

- / Перед монтажом следует проверить изделие на предмет повреждений при перевозке. После монтажа претензии о возмещении ущерба за повреждения при перевозке или повреждения поверхностей не принимаются.
- / Трубы и арматура должны быть установлены, промыты и проверены в соответствии с действующими нормами.
- / Необходимо соблюдать требования по монтажу, действующие в соответствующих странах.
- / 39853000: Применение арматуры при наличии проточного нагревателя не допускается.

ТЕХНИЧЕСКИЕ ДАННЫЕ

Рабочее давление:	не более. 1 МПа
Рекомендуемое рабочее давление:	0,1 - 0,5 МПа
Давления:	1,6 МПа
	(1 МПа = 10 bar = 147 PSI)
Температура горячей воды:	не более. 70°C
Рекомендуемая темп. гор. воды:	65°C
Термическая дезинфекция:	не более. 70°C/4 мин

Изделие предназначено исключительно для питьевой воды!

ОПИСАНИЕ СИМВОЛОВ



Не применяйте силикон, содержащий уксусную кислоту.



ПОДГОНКА (см. стр. 36)

Регулировка ограничителя горячей воды. В сочетании с проточными нагревателями не рекомендуется использовать блокировку воды.

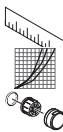

РАЗМЕРЫ (см. стр. 42)

СХЕМА ПОТОКА (см. стр. 42)

КОМПЛЕКТ (см. стр. 44)

XXX = Цветная кодировка
000 = Хром
020 = Polished Chrome
130 = Polished Bronze
140 = Brushed Bronze
250 = Brushed Gold-Optic
260 = Brushed Chrome
300 = Polished Redgold
310 = Brushed Redgold
330 = Polished Black Chrome
340 = Brushed Black Chrome
800 = Stainless Steel Optic
820 = Brushed Nickel
830 = Polished Nickel
930 = Polished Brass
950 = Brushed Brass
990 = Polished Gold-Optic

СПЕЦИАЛЬНЫЕ ПРИНАДЛЕЖНОСТИ (не включено в объем поставки!)

Переходник (G¹/₂/G³/₄) #93395000 (см. стр. 45)



ОЧИСТКА (см. стр. 38)

ЭКСПЛУАТАЦИЯ (см. стр. 37)

Hansgrohe рекомендует по утрам либо после длительного перерыва в использовании не использовать первые поллитра воды для питья.



ЗНАК ТЕХНИЧЕСКОГО КОНТРОЛЯ (см. стр. 43)

НЕИСПРАВНОСТЬ	ПРИЧИНА	УСТРАНЕНИЕ НЕИСПРАВНОСТИ
/ недостаточный давление (если устан напор воды)	/ Аэратор засорен накипью, загрязнен	/ Очистите/замените аэратор
/ Арматура работает с усилием	/ Картридж неисправен, засорение накипью	/ Замените картридж
/ Арматура протекает	/ Картридж неисправен	/ Замените картридж
/ Выход воды у основания крепления	/ Шланги подключения не полностью завернуты в корпус	/ Затяните шланги подключения вручную
	/ Уплотнительное кольцо круглого сечения на соединительном шланге не-исправно	/ Замените уплотнительное кольцо круглого сечения
/ Температура горячей воды слишком низкая	/ Ограничение горячей воды отрегулировано неправильно	/ Отрегулируйте ограничение горячей воды

МОНТАЖ (см. стр. 32)



△ TURVALLISUUSOHJEET

- △ Asennuksessa on käytettävä käsitteitä puristumien ja viiltojen aiheuttamien tapaturmien estämiseksi.
- △ Suuret paine-erot kylmä- ja kuumavesiliitäntöjen välillä on tasattava.

ASENNUSOHJEET

- / Ennen asennusta on tarkastettava tuotteen mahdolliset kuljetusvahingot. Asennuksen jälkeen kuljetus- ja pintavaurioita ei hyväksytä.
- / Putket ja hana on asennettava, huuhdeltava ja tarkastettava voimassa olevien standardien mukaisesti.
- / Jokaisessa maassa on noudatettava siellä päteviä asennusohjeita.
- / 39853000: Armaturia ei voi käyttää läpimenoveden-kuumentimen yhteydessä.

TEKNISET TIEDOT

Käyttöpain:	maks. 1 MPa
Suosittelu käyttöpain:	0,1 - 0,5 MPa
Koestuspaine:	1,6 MPa (1 MPa = 10 bar = 147 PSI)
Kuuman veden lämpötila:	maks. 70°C
Kuuman veden suosituslämpötila:	65°C
Lämpödesinfektio:	maks. 70°C/4 min

Tuote on suunniteltu käytettäväksi ainoastaan juomaveden kanssa!

MERKIN KUVAUS



Älä käytä etikkahappopitoista silikonia!

SÄÄTÖ (katso sivu 36)

Lämpötilan rajoittimen säätäminen. Emme suosittele käyttämään lämpötilan rajoitinta vedenlämmittimen (läpivirtauskuumennin) yhteydessä.



MITAT (katso sivu 42)



VIRTAUSDIAGRAMMI
(katso sivu 42)



VARAOSAT (katso sivu 44)

XXX = Värikoodaus
000 = Kromi
020 = Polished Chrome
130 = Polished Bronze
140 = Brushed Bronze
250 = Brushed Gold-Optic
260 = Brushed Chrome
300 = Polished Redgold
310 = Brushed Redgold
330 = Polished Black Chrome
340 = Brushed Black Chrome
800 = Stainless Steel Optic
820 = Brushed Nickel
830 = Polished Nickel
930 = Polished Brass
950 = Brushed Brass
990 = Polished Gold-Optic

ERITYISVARUSTE (ei kuulu toimitukseen)

Sovitin (G¹/₂/G³/₄) #93395000 (katso sivu 45)



PUHDISTUS (katso sivu 38)

KÄYTTÖ (katso sivu 37)

Hansgrohe suosittelee, että ensimmäistä puolta litraa ei käytetä juomavetenä aamuisin eikä silloin, kun laitetta ei ole käytetty pitkään aikaan.



KOESTUSMERKKI (katso sivu 43)

HÄIRIÖ	SYY	TOIMENPIDE
/ Vähän vettä	/ Poresuutin kalkkeutunut, likaantunut	/ Puhdista/vaihda poresuutin
/ Hana on raskaskäyttöinen	/ Patruuna rikki, kalkkikerrostumia	/ Vaihda patruuna
/ Hanasta tippuu vettä	/ Patruuna rikki	/ Vaihda patruuna
/ Vettä valuu kiinnityskauluksesta	/ Liitosletkut eivät ole kierretty kiinni perusrunkoon pohjaan asti	/ Kierrä liitosletkut kiinni käsikireyteen
	/ Liitosletkun O-renkas on rikki	/ Vaihda O-renkas
/ Lämminveden lämpötila liian alhainen	/ Lämminveden rajoitin väärin säädetty	/ Säädä lämminveden rajoitin

ASENNUS (katso sivu 32)



△ SÄKERHETSANVISNINGAR

- △ Handskar ska bäras under monteringsarbetet så att man kan undvika kläm- och skärskador.
- △ Stora tryckskillnader mellan anslutningarna för varmt och kallt vatten måste utjämnas.

MONTERINGSANVISNINGAR

- / Det måste undersökas om produkten har transportskador innan den monteras. Efter monteringen accepteras inga transport- eller ytskiktsskador.
- / Ledningarna och blandaren måste monteras, spolas igenom och kontrolleras enligt de gällande normerna.
- / De installationsriktlinjer som gäller i länderna ska följas.
- / 39853000: Blandaren kan inte användas tillsammans med en varmvattenberedare.

TEKNISKA DATA

Driftstryck:	max. 1 MPa
Rek. driftstryck:	0,1 - 0,5 MPa
Tryck vid provtryckning:	1,6 MPa (1 MPa = 10 bar = 147 PSI)
Varmvattentemperatur:	max. 70°C
Rek. varmvattentemp.:	65°C
Termisk desinfektion:	max. 70°C / 4 min

Produkten är enbart avsedd för dricksvatten!

SYMBOLFÖRKLARING



Använd inte silikon som innehåller ättiksyra!



JUSTERING (se sidan 36)

Ställa in varmvattenregleringen. Tillsammans med varmvattenberedare rekommenderas inte en varmvattenspärr.



MÅTTEN (se sidan 42)



FLÖDESSCHEMA (se sidan 42)



RESERVDELAR (se sidan 44)

XXX	= Färgkodning
000	= Krom
020	= Polished Chrome
130	= Polished Bronze
140	= Brushed Bronze
250	= Brushed Gold-Optic
260	= Brushed Chrome
300	= Polished Redgold
310	= Brushed Redgold
330	= Polished Black Chrome
340	= Brushed Black Chrome
800	= Stainless Steel Optic
820	= Brushed Nickel
830	= Polished Nickel
930	= Polished Brass
950	= Brushed Brass
990	= Polished Gold-Optic

SPECIALTILLBEHÖR

(medföljer ej leveransen)



Adapter (G $\frac{1}{2}$ /G $\frac{3}{4}$) #93395000 (se sidan 45)



RENGÖRING (se sidan 38)



HANTERING (se sidan 37)

Hansgrohe rekommenderar att den första halvlitern inte används som dricksvatten på morgonen eller efter längre perioder utan användning.



TESTSIGILL (se sidan 43)

STÖRNING

ORSAK

ÅTGÄRD

/ För lite vatten	/ Areator är täckt av kalk, smutsig	/ Rengör/byt areator
/ Blandare är trög	/ Patron defekt, förkalkad	/ Byt ut patron
/ Blandare droppar	/ Patron defekt	/ Byt ut patron
/ Vatten kommer ut vid monteringsstaget	/ Anslutningsslangar inte helt inskruvade i grundkonstruktionen	/ Drag fast anslutningsslangar för hand.
	/ O-ring på anslutningsslang defekt	/ Byt ut O-ring
/ Varmvattentemperaturen är för låg	/ Varmvattenreglering felaktigt inställd	/ Ställ in varmvattenreglering

MONTERING (se sidan 32)



△ SAUGUMO TECHNIKOS NURODYMAI

- △ Apsaugai nuo užspaudimo ir įsijovimo montavimo metu mūvėkite pirštines.
- △ Turi būti išlyginti šalto ir karšto slėgio nelygumai.

MONTAVIMO INSTRUKCIJA

- / Prieš montuojant būtina patikrinti, ar gaminy nebuvo pažeistas transportavimo metu. Sumontavus pretenzijos dėl transportavimo ir paviršiaus pažeidimų nepriimamos.
- / Vamzdžiai ir sujungimai turi būti montuojami, plaunami ir tikrinami pagal galiojančias normas.
- / Laikykitės atitinkamoje šalyje galiojančių direktyvų dėl įrengimo.
- / 39853000: Armatūros negalima naudoti kartu su tekančio vandens šildytuvu.

TECHNINIAI DUOMENYS

- Darbinis slėgis: ne daugiau kaip 1 MPa
 Rekomenduojamas slėgis: 0,1 - 0,5 MPa
 Bandomasis slėgis: 1,6 MPa
 (1 MPa = 10 barų = 147 PSI)
- Karšto vandens temperatūra: ne daugiau kaip 70°C
 Rekomenduojama karšto vandens temperatūra: 65°C
 Terminis dezinfekavimas: ne daugiau kaip 70°C / 4 min
- Produktas skirtas tik geriamajam vandeniui!

SIMBOLIO APRAŠYMAS



Nenaudokite silikono, kurio sudėtyje yra acto rūgšties!



REGULIAVIMAS (žr. psl. 36)

Karšto vandens ribojimas. Kartu su cirkuliaciniais šildytuvais nerekomenduojama naudoti karšto vandens blokavimo įtaisų.



IŠMATAVIMAI (žr. psl. 42)



PRALAUDIMO DIAGRAMA
(žr. psl. 42)



ATSARGINĖS DALYS (žr. psl. 44)

- XXX = Spalvos
- 000 = Chrom
- 020 = Polished Chrome
- 130 = Polished Bronze
- 140 = Brushed Bronze
- 250 = Brushed Gold-Optic
- 260 = Brushed Chrome
- 300 = Polished Redgold
- 310 = Brushed Redgold
- 330 = Polished Black Chrome
- 340 = Brushed Black Chrome
- 800 = Stainless Steel Optic
- 820 = Brushed Nickel
- 830 = Polished Nickel
- 930 = Polished Brass
- 950 = Brushed Brass
- 990 = Polished Gold-Optic

SPECIALŪS PRIEDAI (nėra pridedama)

Adapteris (G $\frac{1}{2}$ /G $\frac{3}{4}$) #93395000 (žr. psl. 45)



VALYMAS (žr. psl. 38)

EKSPLOATACIJA (žr. psl. 37)

Naudojant po ilgesnės pertraukos, „Hansgrohe“ rekomenduoja pirmo pusės litro vandens nevartoti kaip geriamojo.



BANDYMO PAŽYMA (žr. psl. 43)

GEDIMAS	PRIEŽASTIS	PRIEMONĖ
/ Per maža srovė	/ Perlatorius apkalkėjęs, užsikimšęs	/ Perlatorių išvalyti/pakeisti
/ Sunkiai sukiojama rankenėlė	/ Kasetė pažeista, užkalkėjusi	/ Pakeisti kasetę
/ Maišytuvus praleidžia vandenį	/ Kasetė pažeista	/ Pakeisti kasetę
/ Prateka vanduo per tvirtinimo kotą	/ Prijungimo žarnos nepilnai įsuktos į korpusą	/ Prijungimo žarnas prisukti ranka
	/ Pajungimo žarnos tarpinė pažeista	/ tarpinę pakeisti
/ Per maža karšto vandens temperatūra	/ Neteisingai nustatytas karšto vandens ribotuvus	/ Nustatyti karšto vandens ribotuvą

MONTAVIMAS (žr. psl. 32)



△ SIGURNOSNE UPUTE

- △ Prilikom montaže se radi sprječavanja prignječenja i posjekotina moraju nositi rukavice.
- △ Velika razlika u pritisku između vruće i hladne vode mora biti izbalansirana.

UPUTE ZA MONTAŽU

- / Prije montaže mora se provjeriti je li proizvod oštećen prilikom transporta. Nakon ugradnje se ne priznaju nikakve reklamacije koje se odnose na površinska i transportna oštećenja.
- / Cijevi i armatura moraju biti postavljeni, isprani i testirani prema važećim normama.
- / Obvezno se moraju uvažiti propisi o instalacijama koji vrijede u dotičnoj zemlji.
- / 39853000: Armatura se ne može rabiti u kombinaciji sa protočnim bojlerom.

TEHNIČKI PODATCI

Najveći dopušteni tlak:	tlak 1 MPa
Preporučeni tlak:	0,1 - 0,5 MPa
Probni tlak:	1,6 MPa
	(1 MPa = 10 bar = 147 PSI)
Temperatura vruće vode:	tlak 70°C
Preporučena temperatura vruće vode:	65°C
Termička dezinfekcija:	tlak 70°C / 4 min

Proizvod je koncipiran isključivo za pitku vodu!

OPIS SIMBOLA



Nemojte koristiti silikon koji sadrži octenu kiselinu!



REGULACIJA (pogledaj stranicu 36)

Namještanje limitera tople vode. U kombinaciji s protočnim bojlerima nije preporučljiva primjena sustava za blokiranje dotoka tople vode.



MJERE (pogledaj stranicu 42)



DIJAGRAM PROTOKA
(pogledaj stranicu 42)



REZERVNI DJELOVI
(pogledaj stranicu 44)

XXX = Boje
000 = Krom
020 = Polished Chrome
130 = Polished Bronze
140 = Brushed Bronze
250 = Brushed Gold-Optic
260 = Brushed Chrome
300 = Polished Redgold
310 = Brushed Redgold
330 = Polished Black Chrome
340 = Brushed Black Chrome
800 = Stainless Steel Optic
820 = Brushed Nickel
830 = Polished Nickel
930 = Polished Brass
950 = Brushed Brass
990 = Polished Gold-Optic

POSEBNI PRIBOR

(Nije sadržano u isporuci!)



Prilagodnik (G $\frac{1}{2}$ /G $\frac{3}{4}$) #93395000
(pogledaj stranicu 45)



ČIŠĆENJE (pogledaj stranicu 38)



UPOTREBA (pogledaj stranicu 37)

Hansgrohe preporuča da ujutro ili nakon duljeg nekorištenja prvih 1/2 litre vode ne upotrebljavate za piće.



OZNAKA TESTIRANJA
(pogledaj stranicu 43)

GREŠKA	UZROK	OTKLANJANJE
/ Nedovoljno vode	/ Aerator je začepljen naslagama kalcija ili prljav	/ Očistite ili zamijenite aerator.
/ Ručica se zaglavila	/ Neispravan uložak Taloženje kamenca	/ Zamijenite uložak
/ Slavina kaplje	/ Neispravan uložak	/ Zamijenite uložak
/ Voda izlazi na dijelu gdje je slavina učvršćena	/ Priključna crijeva nisu potpuno učvršćena na na tijelo	/ Priključna crijeva učvrstite rukom
	/ O-prsteni priključnih crijeva su neispravni	/ Zamijenite O-prsten
/ Preniska temperatura tople vode	/ Limiter vruće vode nije dobro podešen	/ Podesite limiter vruće vode

SASTAVLJANJE (pogledaj stranicu 32)



△ GÜVENLİK UYARILARI

- △ Montaj esnasında ezilme ve kesilme gibi yaralanmaları önlemek için eldiven kullanılmalıdır.
- △ Sıcak ve soğuk su bağlantıları arasında büyük basınç farklılıkları varsa, bu basınç farklılıklarının dengelenmesi gerekir.

MONTAJ AÇIKLAMALARI

- / Montaj işleminden önce ürün nakliye hasarları yönünden kontrol edilmelidir. Montaj işleminden sonra nakliye veya yüzey hasarları için sorumluluk üstlenilmemektedir.
- / Boruların ve armatürün montajı, yıkanması ve kontrolü geçerli normlara göre yapılmalıdır.
- / Ülkelerde geçerli kurulum yönetmeliklerine riayet edilmelidir.
- / 39853000: Armatür bir akış ısıtıcısı ile birlikte kullanılabilir.

TEKNİK BİLGİLER

İşletme basıncı:	azami 1 MPa
Tavsiye edilen işletme basıncı:	0,1 - 0,5 MPa
Kontrol basıncı:	1,6 MPa
	(1 MPa = 10 bar = 147 PSI)
Sıcak su sıcaklığı:	azami 70°C
Tavsiye edilen su ısı:	65°C
Termik dezenfeksiyon:	azami 70°C/4 dak
Ürün sadece şebeke suyu için tasarlanmıştır!	

SİMGE AÇIKLAMASI

 Asetik asit içeren silikon kullanmayın!

 AYARLAMA (bakınız sayfa 36)

Sıcak su sınırlamasının ayarlanması. Sıcak su kilidinin sürekli ısıtıcıyla kullanılması tavsiye edilmez.

 ÖLÇÜLERİ (bakınız sayfa 42)

ARIZA	SEBEP	YARDIM
/ Az su geliyor	/ Perlatör kireçlenmiş, kirlenmiş	/ Perlatör kireçlenmiş, kirlenmiş
/ Batarya kullanımı ağırlaşıyor	/ Kartuş Bozulmuş ve kireçlenmiş olabilir	/ Kartuşu değiştirin
/ Batarya su damlatıyor	/ Kartuş bozuk olabilir	/ Kartuşu değiştirin
/ Sabitleme kutusundan su çıkışı	/ Bağlantı hortumları ana gövdeye tamamen vidalanmamış	/ Bağlantı hortumlarını elinizle sıkın
	/ Bağlantı hortumundaki O-ring arızalı	/ O-ringi değiştirin
/ Sıcak suyun derecesi çok düşük	/ Isı limitleyici düzgün çalışmıyor	/ Isı limitleyiciyi yeniden ayarlayın



AKIŞ DİYAGRAMI (bakınız sayfa 42)



YEDEK PARÇALAR (bakınız sayfa 44)

- XXX = Renkler
- 000 = Krom
- 020 = Polished Chrome
- 130 = Polished Bronze
- 140 = Brushed Bronze
- 250 = Brushed Gold-Optic
- 260 = Brushed Chrome
- 300 = Polished Redgold
- 310 = Brushed Redgold
- 330 = Polished Black Chrome
- 340 = Brushed Black Chrome
- 800 = Stainless Steel Optic
- 820 = Brushed Nickel
- 830 = Polished Nickel
- 930 = Polished Brass
- 950 = Brushed Brass
- 990 = Polished Gold-Optic

ÖZEL AKSESUARLAR

(Teslimat kapsamına dahil değildir)

 Adaptör (G¹/₂/G³/₄) #93395000 (bakınız sayfa 45)



TEMİZLEME (bakınız sayfa 38)

 KULLANIMI (bakınız sayfa 37)

Hansgrohe sabahları uzun durgunluk süresi sonrasında ilk yarım litre suyun içme suyu olarak kullanılmamasını önerir.



KONTROL İŞARETİ (bakınız sayfa 43)

MONTAJI (bakınız sayfa 32)



△ INSTRUCȚIUNI DE SIGURANȚĂ

- △ La montare utilizați mănuși pentru evitarea contuziunilor și tăierii mâinilor.
- △ Diferențele de presiune mari între alimentarea cu apă rece și apă caldă trebuie echilibrate.

INSTRUCȚIUNI DE MONTARE

- / Înainte de instalare verificați, dacă produsul prezintă deteriorări de transport. După instalare garanția nu acoperă deteriorările de transport și cele de suprafață.
- / Conductele și bateriile trebuie montate, spălate și verificate conform normelor în vigoare.
- / Respectați reglementările referitoare la instalare valabile în țara respectivă.
- / 39853000: Bateria nu poate fi utilizată în combinație cu un boiler în flux continuu.

DATE TEHNICE

Presiune de funcționare:	max. 1 MPa
Presiune de funcționare recomandată:	0,1 - 0,5 MPa
Presiune de verificare:	1,6 MPa (1 MPa = 10 bar = 147 PSI)
Temperatura apei calde:	max. 70°C
Temperatura recomandată a apei calde:	65°C
Dezinfecție termică:	max. 70°C/4 min

Produsul este destinat exclusiv pentru apă potabilă.

DESCRIEREA SIMBOLURILOR



Nu utilizați silicon cu conținut de acid acetic!



REGLARE (vezi pag. 36)

Reglarea limitatorului de apă caldă. Nu se recomandă folosirea unui limitator de apă caldă în combinație cu un boiler instant.



DIMENSIUNI (vezi pag. 42)



DIAGRAMA DE DEBIT
(vezi pag. 42)

DERANJAMENT

CAUZA

MĂSURI DE REMEDIERE

/ Prea puțină apă	/ Depuneri de calcar și impurități pe pulverizatorul de aer.	/ Curățați/schimbați pulverizatorul de aer.
/ Bateria se mișcă dificil	/ Cartuș defect din cauza depunerilor de calcar	/ Schimbați cartușul.
/ Bateria picură	/ Cartuș defect	/ Schimbați cartușul.
/ Scurgere de apă la șaftul de fixare.	/ Furtunurile de racordare nu sunt bine înșurubate în corpul bateriei. / Inelul O de la furtunul de racord defect	/ Strângeți cu mâna furtunurile de racordare. / Schimbați inelul O.
/ Temperatura apei calde este prea mică	/ Limitarea temperaturii apei calde setată incorect.	/ Setați limitarea temperaturii apei calde.

MONTARE (vezi pag. 32)



PIESE DE SCHIMB (vezi pag. 44)

XXX =	Coduri de culori
000 =	Crom
020 =	Polished Chrome
130 =	Polished Bronze
140 =	Brushed Bronze
250 =	Brushed Gold-Optic
260 =	Brushed Chrome
300 =	Polished Redgold
310 =	Brushed Redgold
330 =	Polished Black Chrome
340 =	Brushed Black Chrome
800 =	Stainless Steel Optic
820 =	Brushed Nickel
830 =	Polished Nickel
930 =	Polished Brass
950 =	Brushed Brass
990 =	Polished Gold-Optic

ACCESORII OPȚIONALE

(nu este inclus în setul livrat)



Adaptor (G¹/₂ / G³/₄) #93395000 (vezi pag. 45)



CURĂȚARE (vezi pag. 38)



UTILIZARE (vezi pag. 37)

Hansgrohe vă recomandă, ca dimineața sau după perioade mai lungi de pauză să nu folosiți prima jumătate de litru de apă pentru băut.



CERTIFICAT DE TESTARE

(vezi pag. 43)

ΔΥΠΟΔΕΙΞΕΙΣ ΑΣΦΑΛΕΙΑΣ

- Δ Για να αποφύγετε τραυματισμούς κατά τη συναρμολόγηση πρέπει να φοράτε γάντια.
- Δ Οι διαφορές της πίεσης μεταξύ της σύνδεσης κρύου και ζεστού νερού θα πρέπει να αντισταθμίζονται.

ΟΔΗΓΙΕΣ ΣΥΝΑΡΜΟΛΟΓΗΣΗΣ

- / Πριν τη συναρμολόγηση πρέπει να εξεταστεί το προϊόν για ζημιές μεταφοράς. Μετά την εγκατάσταση δεν αναγνωρίζονται ζημιές από τη μεταφορά ή επιφανειακές ζημιές.
- / Οι σωλήνες και η μπαταρία πρέπει να τοποθετηθούν σύμφωνα με τα ισχύοντα πρότυπα, να τεθούν υπό πίεση και να δοκιμαστούν.
- / Θα πρέπει να τηρούνται οι οδηγίες εγκατάστασης που ισχύουν σε κάθε κράτος.
- / 39853000: Η μπαταρία δεν μπορεί να χρησιμοποιηθεί σε συνδυασμό με ταχυθερμοσίφωνα.

ΤΕΧΝΙΚΑ ΧΑΡΑΚΤΗΡΙΣΤΙΚΑ

Λειτουργία πίεσης:	έως 1 MPa
Συνιστώμενη λειτουργία πίεσης:	0,1 - 0,5 MPa
Πίεση ελέγχου:	1,6 MPa
	(1 MPa = 10 bar = 147 PSI)
Θερμοκρασία ζεστού νερού:	έως 70°C
Συνιστώμενη θερμοκρασία ζεστού νερού:	65°C
Θερμική απολύμανση:	έως 70°C / 4 min
Το προϊόν έχει σχεδιαστεί αποκλειστικά για πόσιμο νερό!	

ΠΕΡΙΓΡΑΦΗ ΣΥΜΒΟΛΩΝ



Μην χρησιμοποιείτε σιλικόνη που περιέχει οξικό οξύ!



ΡΥΘΜΙΣΗ (βλ. Σελίδα 36)

Ρύθμιση του δοσομετρητή ζεστού νερού. Δεν συνιστάται η διάταξη φραγής ζεστού νερού σε συνδυασμό με ταχυθερμοσίφωνα.

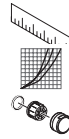

ΔΙΑΣΤΑΣΕΙΣ (βλ. Σελίδα 42)

ΔΙΑΓΡΑΜΜΑ ΡΟΗΣ (βλ. Σελίδα 42)

ΑΝΤΑΛΛΑΚΤΙΚΑ (βλ. Σελίδα 44)

XXX = Χρώματα
000 = Επιχρωμιωμένο
020 = Polished Chrome
130 = Polished Bronze
140 = Brushed Bronze
250 = Brushed Gold-Optic
260 = Brushed Chrome
300 = Polished Redgold
310 = Brushed Redgold
330 = Polished Black Chrome
340 = Brushed Black Chrome
800 = Stainless Steel Optic
820 = Brushed Nickel
830 = Polished Nickel
930 = Polished Brass
950 = Brushed Brass
990 = Polished Gold-Optic

ΕΙΔΙΚΑ ΑΞΕΣΟΥΡΑ (δεν περιλαμβάνεται στον παραδοτέο εξοπλισμό)



Προσαρμογέας (G½/G¾) #93395000 (βλ. Σελίδα 45)



ΚΑΘΑΡΙΣΜΟΣ (βλ. Σελίδα 38)



ΧΕΙΡΙΣΜΟΣ (βλ. Σελίδα 37)

Η Hansgrohe συνιστά το πρωί ή μετά από μεγάλα χρονικά διαστήματα αχρησίας να μην χρησιμοποιείτε το πρώτο μισό λίτρο νερό σαν πόσιμο.

ΣΗΜΑ ΕΛΕΓΧΟΥ (βλ. Σελίδα 43)



ΒΛΑΒΗ

ΑΙΤΙΑ

ΔΙΟΡΘΩΣΗ

/ Ανεπαρκές νερό	/ Άλατα και βρωμιά στο φίλτρο	/ Καθαρίστε/αλλάξτε το φίλτρο
/ Σκληρή μπαταρία (μείκτης)	/ Ελαττωματικό φυσιγγιο, άλατα	/ Αλλαγή φυσιγγίου
/ Η μπαταρία στάζει	/ Ελαττωματικό φυσιγγιο	/ Αλλαγή φυσιγγίου
/ Διαρροή νερού στον άξονα στερέωσης	/ Οι σωλήνες σύνδεσης δεν είναι πλήρως βιδωμένοι στο βασικό κορμό	/ Σφίξτε τους σωλήνες σύνδεσης με το χέρι
	/ Ο στρογγυλός δακτύλιος στο σωλήνα σύνδεσης είναι ελαττωματικός	/ Αλλάξτε το στρογγυλό δακτύλιο
/ Χαμηλή θερμοκρασία ζεστού νερού	/ Λάθος ρύθμιση της περιοριστικής διάταξης ζεστού νερού	/ Ρυθμίστε την περιοριστική διάταξη του ζεστού νερού

ΣΥΝΑΡΜΟΛΟΓΗΣΗ (βλ. Σελίδα 32)



△ VARNOSTNA OPOZORILA

- △ Pri montaži je treba nositi rokavice, da se preprečijo poškodbe zaradi zmečkanja ali urezov.
- △ Velike razlike v tlaku med priključkom za mrzlo in priključkom za toplo vodo je potrebno izravnati.

NAVODILA ZA MONTAŽO

- / Pred montažo je treba izdelek preveriti glede morebitnih transportnih poškodb. Po vgradnji transportne ali površinske poškodbe ne bodo več priznane.
- / Cevi in armaturo je treba montirati, izprati in preveriti po veljavnih standardih.
- / Upoštevati je treba pravilnike o inštalacijah, ki veljajo v posamezni državi.
- / 39853000: Armature ni možno uporabiti v povezavi s pretočnim grelnikom.

TEHNIČNI PODATKI

Delovni tlak:	maks. 1 MPa
Priporočeni delovni tlak:	0,1 - 0,5 MPa
Preskusni tlak:	1,6 MPa
	(1 MPa = 10 bar = 147 PSI)
Temperatura tople vode:	maks. 70°C
Priporočena temperatura tople vode:	65°C
Termična dezinfekcija:	maks. 70°C/4 min
Proizvod je zasnovan izključno za sanitarno vodo!	

OPIS SIMBOLA

Ne smete uporabiti silikona, ki vsebuje ocatno kislino!



J U S T I R A N J E (glejte stran 36)

Nastavitev omejevalnika tople vode. V povezavi s pretočnimi grelniki uporaba zapore tople vode ni priporočljiva.



M E R E (glejte stran 42)



DIAGRAM PRETOKA
(glejte stran 42)



REZERVNI DELI (glejte stran 44)

XXX = Barve
000 = Krom
020 = Polished Chrome
130 = Polished Bronze
140 = Brushed Bronze
250 = Brushed Gold-Optic
260 = Brushed Chrome
300 = Polished Redgold
310 = Brushed Redgold
330 = Polished Black Chrome
340 = Brushed Black Chrome
800 = Stainless Steel Optic
820 = Brushed Nickel
830 = Polished Nickel
930 = Polished Brass
950 = Brushed Brass
990 = Polished Gold-Optic

POSEBEN PRIBOR (Ni vključeno)



Adapter (G $\frac{1}{2}$ /G $\frac{3}{4}$) #93395000
(glejte stran 45)



Č I Š Č E N J E (glejte stran 38)



U P R A V L J A N J E (glejte stran 37)

Hansgrohe priporoča, da zjutraj ali po daljšem času stagnacije prvega pol litra vode ne uporabite kot pitno vodo.



P R E S K U S N I Z N A K (glejte stran 43)

N A P A K A	V Z R O K	P O M O Č
/ Malo vode	/ Perlator poapnen; umazan	/ Očistite/zamenjajte perlator
/ Težko premikanje armature	/ Pokvarjen vložek, poapneno	/ Zamenjajte vložek
/ Iz armature kaplja	/ Pokvarjen vložek	/ Zamenjajte vložek
/ Uhajanje vode ob pritrdilnem nastavku	/ Priključne cevi niso popolnoma privijačene v osnovno ogrodje	/ Ročno zatisnite priključne cevi
	/ Obročna tesnila priključnih gibkih cevi so pokvarjena	/ Zamenjajte obročno tesnilo
/ Prenizka temperatura tople vode	/ Omejevalnik tople vode ni pravilno nastavljen	/ Nastavite omejevalnik tople vode

M O N T A Ž A (glejte stran 32)



△ OHUTUSJUHISED

- △ Kandke paigaldamisel muljumis- ja löikevigastuste vältimiseks kindaid.
- △ Kui külma ja kuumaa vee ühenduste surve on väga erinev, tuleb need tasakaalustada.

PAIGALDAMISJUHISED

- / Enne paigaldamist tuleb toodet kontrollida transpordikahjustuste osas. Pärast paigaldamist ei tunnustata enam transpordi- või pinnakahjustuste kaebuseid.
- / Voolikute ja segisti paigaldamisel, loputamisel ja kontrollimisel tuleb lähtuda kehtivatest normatiividest.
- / Vastavas riigis kehtivaid paigalduseeskirju tuleb järgida.
- / 39853000: Segistit ei saa kasutada koos läbivooluveesoojendiga.

TEHNILISED ANDMED

Töörõhk	maks. 1 MPa
Soovitatav töörõhk:	0,1 - 0,5 MPa
Kontrollsurve:	1,6 MPa (1 MPa = 10 baari = 147 PSI)
Kuumaa vee temperatuur:	maks. 70°C
Soovitatav kuumaa vee temperatuur:	65°C
Terminaalne desinfitatsioon:	maks. 70°C / 4 min

Toode on ette nähtud eranditult joogivee jaoks!

SÜMBOLITE KIRJELDUS



Ärge kasutage äädikhapet sisaldavat silikooni!

REGULEERIMINE (vt lk 36)

Soojaa vee piirangu seadistamine. Ühenduses boileritega ei ole sooojaa vee blokeeringu soovitatav.



MÕÖTUDE (vt lk 42)

LÄBIVOOLUDIAGRAMM (vt lk 42)

RIKE

- / Vähe vett
- / Segisti käib raskelt
- / Segisti tilgub
- / Veeleke kinnituse juures

PÕHJUS

- / Sõel on lupjunud, must
- / Tööelement on katkine, lubjastunud
- / Tööelement on katkine
- / Ühendusvoolikud ei ole korralikult põhi- / korpuse külge kruvitud
- / Ühendusvoolikute O-rõngastihendid katki

LAHENDUS

- / Puhastage segisti sõel vajadusel vahetage
- / Vahetage tööelement
- / Vahetage tööelement
- / Kruvige ühendusvoolikud käega kinni
- / Vahetage O-rõngastihend
- / Seadke kuumaa vee piirang

- / Sooojaa vee temperatuur liiga madal

- / Kuumaa vee piirang valesti seatud



VARUOSAD (vt lk 44)

- XXX = Värvid
- 000 = Kroom
- 020 = Polished Chrome
- 130 = Polished Bronze
- 140 = Brushed Bronze
- 250 = Brushed Gold-Optic
- 260 = Brushed Chrome
- 300 = Polished Redgold
- 310 = Brushed Redgold
- 330 = Polished Black Chrome
- 340 = Brushed Black Chrome
- 800 = Stainless Steel Optic
- 820 = Brushed Nickel
- 830 = Polished Nickel
- 930 = Polished Brass
- 950 = Brushed Brass
- 990 = Polished Gold-Optic

SPETSIAALNE LISAVARUSTUS

(ei sisaldu komplektis)



Adapter (G $\frac{1}{2}$ / G $\frac{3}{4}$) #93395000 (vt lk 45)



PUHASTAMINE (vt lk 38)

KASUTAMINE (vt lk 37)

Hansgrohe soovitatav mitte kasutada esimest poolt liitrit hommikuti või pärast pikemat seisakuaega joogiveena.



KONTROLLSERTIFIKAAT (vt lk 43)

PAIGALDAMINE (vt lk 32)



△ DROŠĪBAS NORĀDES

- △ Montāžas laikā, lai izvairītos no saspiedumiem un iegrīzumiem, nepieciešams nēsāt cimdus.
- △ Jāizlīdzina spiediena atšķirības starp aukstā un karstā ūdens pievadiem.

NORĀDĪJUMI MONTĀŽAI

- / Pirms montāžas nepieciešams pārbaudīt, vai produktam transportēšanas laikā nav radušies bojājumi. Pēc iebūvēšanas bojājumi, kas radušies transportēšanas laikā, vai virsmas bojājumi netiek atzīti.
- / Caurulvadi un armatūra ir jāuzstāda, jāizskalo un jāpārbauda saskaņā ar spēkā esošajiem standartiem.
- / Jāievēro attiecīgās valstīs spēkā esošās montāžas prasības.
- / 39853000: Armatūru nevar izmantot kopā ar caurplūdes sildītāju.

TEHNISKIE DATI

- Darba spiediens: maks. 1 MPa
Ieteicamais darba spiediens: 0,1 - 0,5 MPa
Pārbaudes spiediens: 1,6 MPa
(1 MPa = 10 bar = 147 PSI)
- Karstā ūdens temperatūra: maks. 70°C
Ieteicamā karstā ūdens temperatūra: 65°C
Termiskā dezinfekcija: maks. 70°C / 4 min
- Izstrādājums ir paredzēts tikai dzeramajam ūdenim!

SIMBOLU NOZĪME



Neizmantot silikonu, kas satur etiķskābi!



IEREGULĒŠANA (skat. lpp. 36)

Karsta ūdens ierobežotāja regulēšana. Kopā ar caurteces sildītājiem nav ieteicams izmantot ūdens bloķētāju.



IZMĒRUS (skat. lpp. 42)



CAURPLŪDES DIAGRAMMA
(skat. lpp. 42)



REZERVES DAĻAS (skat. lpp. 44)

XXX = Krāsu kodi
000 = Hroma
020 = Polished Chrome
130 = Polished Bronze
140 = Brushed Bronze
250 = Brushed Gold-Optic
260 = Brushed Chrome
300 = Polished Redgold
310 = Brushed Redgold
330 = Polished Black Chrome
340 = Brushed Black Chrome
800 = Stainless Steel Optic
820 = Brushed Nickel
830 = Polished Nickel
930 = Polished Brass
950 = Brushed Brass
990 = Polished Gold-Optic

SPECIĀLI AKSESUĀRI
(komplektā netiek piegādāts)



Adapteris (G $\frac{1}{2}$ /G $\frac{3}{4}$) #93395000
(skat. lpp. 45)



TĪRĪŠANA (skat. lpp. 38)



LIEĻŪŠANA (skat. lpp. 37)

Hansgrohe iesaka no rīta vai pēc ilgākiem pārtraukumiem nelietot pirmo puslitru ūdens dzeršanai.



PĀRBAUDES ZĪME (skat. lpp. 43)

TRAUCĒJUMS

IEMESLS

BOJĀJUMU NOVĒRŠANA

/ Maz ūdens	/ Aerators aizkaļķojies, aizsērējis	/ Tīrīt/nomainīt aeratoru
/ Jaucējkrāns smagi grozāms	/ Bojāta kartuša, aizkaļķojusies	/ Nomainīt kartušu
/ Jaucējkrāns pil	/ Bojāta kartuša	/ Nomainīt kartušu
/ Ūdens noplūde pie nostiprinājuma	/ Pieslēguma šļūtenes nav līdz galam ieskrūvētas pamatelementā	/ Pieslēguma šļūtenes ar roku pievilkt stingrāk
	/ Bojāti pieslēguma šļūtenju O-gredzeni	/ Nomainīt O-gredzenu
/ Pārāk zema ūdens temperatūra	/ Nepareizi noregulāta karstā ūdens bloķēšana	/ Noregulēt karstā ūdens ierobežošanu

MONTĀŽA (skat. lpp. 32)



△ SIGURNOSNE NAPOMENE

- △ Prilikom montaže se radi sprečavanja prignječenja i posekotine moraju nositi rukavice.
- △ Velika razlika u pritisku između vruće i hladne vode mora biti izbalansirana.

INSTRUKCIJE ZA MONTAŽU

- / Pre montaže se mora proveriti da li je proizvod oštećen pri transportu. Nakon ugradnje se ne priznaju nikakve reklamacije koje se odnose na površinska i transportna oštećenja.
- / Vodovi i armatura moraju biti postavljeni, isprani i testirani prema važećim normama.
- / Treba se pridržavati propisa koji u određenim zemljama važe za instalacije.
- / 39853000: Armatura se ne može upotrebljavati u kombinaciji sa protočnim bojlerom.

TEHNIČKI PODACI

Radni pritisak:	maks. 1 MPa
Preporučeni radni pritisak:	0,1 - 0,5 MPa
Probni pritisak:	1,6 MPa
	(1 MPa = 10 bar = 147 PSI)
Temperatura vruće vode:	maks. 70°C
Preporučena temperatura vruće vode:	65°C
Termička dezinfekcija:	maks. 70°C / 4 min
Proizvod je koncipiran isključivo za pijaću vodu!	

OPIS SIMBOLA



Nemojte koristiti silikon koji sadrži siričetu kiselinu!



PODEŠAVANJE (vidi stranu 36)

Podešavanje ograničavača tople vode. U kombinaciji sa protočnim bojlerima ne preporučuje se primena sistema za blokiranje dotoka tople vode.



MERE (vidi stranu 42)

DIJAGRAM PROTOKA
(vidi stranu 42)



REZERVNI DELOVI (vidi stranu 44)

XXX = Oznake boja
 000 = Hrom
 020 = Polished Chrome
 130 = Polished Bronze
 140 = Brushed Bronze
 250 = Brushed Gold-Optic
 260 = Brushed Chrome
 300 = Polished Redgold
 310 = Brushed Redgold
 330 = Polished Black Chrome
 340 = Brushed Black Chrome
 800 = Stainless Steel Optic
 820 = Brushed Nickel
 830 = Polished Nickel
 930 = Polished Brass
 950 = Brushed Brass
 990 = Polished Gold-Optic

POSEBAN PRIBOR

(Nije sadržano u isporuci)



Adapter (G $\frac{1}{2}$ /G $\frac{3}{4}$) #93395000
(vidi stranu 45)



ČIŠĆENJE (vidi stranu 38)



RUKOVANJE (vidi stranu 37)

Hansgrohe preporučuje da ujutru ili nakon dužeg nekorišćenja prvih pola litre vode ne koristite za piće.



ISPITNI ZNAK (vidi stranu 43)

SMETNJA	UZROK	POMOĆ
/ Nedovoljno vode	/ Aerator je začepljen naslagama kamenca ili prljav	/ Očistite ili zamenite aerator
/ Ručica se zaglavila	/ Neispravna kartuša, nataloženi kamenac	/ Zamenite kartušu
/ Slavina kaplje	/ Neispravna kartuša	/ Zamenite kartušu
/ Voda izlazi na delu gde je slavina učvršćena	/ Priključna creva nisu potpuno učvršćena na telo	/ Priključna creva učvrstite rukom
	/ O prstenovi priključnih creva su neispravni	/ Zamenite O prsten
/ Preniska temperatura tople vode	/ Ograničavač vruće vode nije dobro podešen	/ Podesite ograničavač vruće vode

MONTAŽA (vidi stranu 32) 

△ SIKKERHETSHENVISNINGER

- △ Bruk hansker under montasjen for å unngå klem- og kuttskader.
- △ Store trykkdifferanser mellom kaldt- og varmtvannstilkoblinger skal utlignes.

MONTAGEHENVISNINGER

- / Før montasjen skal produktet sjekkes for transportskader. Etter monteringen aksepteres ikke noen transport- eller overflateskader.
- / Ledningene og armaturen skal monteres, spyles og sjekkes iht. de gjeldende normer.
- / Gjeldende retningslinjer for rørleggerarbeid i de enkelte land skal følges.
- / 39853000: Armaturen kan ikke brukes i forbindelse med en gjennomstrømningsvarmer.

TEKNISKE DATA

Driftstrykk	maks. 1 MPa
Anbefalt driftstrykk:	0,1 - 0,5 MPa
Prøvetrykk	1,6 MPa (1 MPa = 10 bar = 147 PSI)
Varmtvannstemperatur	maks. 70°C
Anbefalt temperatur for varmt vann	65°C
Termisk desinfisering:	maks. 70°C/4 min
Produktet er utelukkende designet for drikkevann!	

SYMBOLBESKRIVELSE



Ikke bruk silikon som inneholder eddiksyre!

JUSTERING (se side 36)

Innstilling av varmtvannsbegrensning. I forbindelse med gjennomstrømningsvarmere er det ikke anbefalt å bruke en varmtvannsperre.



MÅL (se side 42)



GJENNOMSTRØMNINGSDIAGRAM
(se side 42)



SERVICEDELER (se side 44)

XXX = Fargekode
000 = Krom
020 = Polished Chrome
130 = Polished Bronze
140 = Brushed Bronze
250 = Brushed Gold-Optic
260 = Brushed Chrome
300 = Polished Redgold
310 = Brushed Redgold
330 = Polished Black Chrome
340 = Brushed Black Chrome
800 = Stainless Steel Optic
820 = Brushed Nickel
830 = Polished Nickel
930 = Polished Brass
950 = Brushed Brass
990 = Polished Gold-Optic

EKSTRATILBEHØR

(ikke med i leveransen)



Adapter (G½/G¾) #93395000 (se side 45)



RENGJØRING (se side 38)



BETJENING (se side 37)

Om morgen og etter lengre stagnasjonstider anbefaler Hansgrohe å ikke bruke den første halvliteren som drikkevann.



PRØVEMERKE (se side 43)

FEIL	ÅRSAK	FEILRETTELSE
/ Lite vann	/ Luftsprudler forkalket, skitten	/ Luftsprudler rengjøres/byttes
/ Armatur ikke lett bevegelig	/ Kartusj defekt, forkalkning	/ Kartusj byttes
/ Armatur drypper	/ Kartusj defekt	/ Kartusj byttes
/ Vannlekkasje på festeskraft	/ Tilkoblingsslanger ikke skrudd helt inn i basiselement	/ Tilkoblingsslanger trekkes fast fra hånd
	/ O-ring på tilkoblingsslangen defekt	/ O-ring byttes
/ For lav varmtvannstemperatur	/ Varmtvannsbegrensning er feil innstilt	/ Varmtvannsbegrensning innstilles

MONTASJE (se side 32)



△ УКАЗАНИЯ ЗА БЕЗОПАСНОСТ

- △ При монтажа трябва да се носят ръкавици, за да се избегнат наранявания поради притискане или порязване.
- △ Големите разлики в налягането между изводите за студената и топлата вода трябва да се изравняват.

УКАЗАНИЯ ЗА МОНТАЖ

- / Преди монтажа продуктът трябва да се провери за транспортни щети. След монтажа не се признават транспортни или повърхностни щети.
- / Тръбопроводите и арматурата трябва да се монтират, промият и проверят в съответствие с валидните норми.
- / Трябва да бъдат спазвани валидните в съответните страни предписания за инсталиране.
- / 39853000: Арматурата не може да се използва във връзка с проточен нагревател.

ТЕХНИЧЕСКИ ДАННИ

Работно налягане:	макс. 1 МПа
Препоръчително работно налягане:	0,1 - 0,5 МПа
Контролно налягане:	1,6 МПа (1 МПа = 10 bar = 147 PSI)
Температура на горещата вода:	макс. 70°C
Препоръчителна температура на горещата вода:	65°C
Термична дезинфекция:	макс. 70°C / 4 мин
Продуктът е разработен само за питейна вода!	

ОПИСАНИЕ НА СИМВОЛИТЕ



Не използвайте силикон, съдържащ оцветна киселина!



ЮСТИРАНЕ (вижте стр. 36)

Настройка на ограничителя за топлата вода.
Във връзка с проточни нагреватели не се препоръчва блокировка за топлата вода



РАЗМЕРИ (вижте стр. 42)

ДИАГРАМА НА ПОТОКА
(вижте стр. 42)



СЕРВИЗНИ ЧАСТИ (вижте стр. 44)

XXX = Цветово кодиране
000 = Хром
020 = Polished Chrome
130 = Polished Bronze
140 = Brushed Bronze
250 = Brushed Gold-Optic
260 = Brushed Chrome
300 = Polished Redgold
310 = Brushed Redgold
330 = Polished Black Chrome
340 = Brushed Black Chrome
800 = Stainless Steel Optic
820 = Brushed Nickel
830 = Polished Nickel
930 = Polished Brass
950 = Brushed Brass
990 = Polished Gold-Optic

СПЕЦИАЛНИ ПРИНАДЛЕЖНОСТИ
(не се съдържа в обема на доставка)



Адаптер (G $\frac{1}{2}$ /G $\frac{3}{4}$) #93395000
(вижте стр. 45)



ПОЧИСТВАНЕ (вижте стр. 38)



ОБСЛУЖВАНЕ (вижте стр. 37)

Hansgrohe препоръчва, сутрин и след по-продължително спиране първият половин литър да не се използва като питейна вода.



КОНТРОЛЕН ЗНАК (вижте стр. 43)

НЕИЗПРАВНОСТ	ПРИЧИНА	ПОМОЩ
/ Малко вода	/ Аераторът е покрит с варовик, замърсен	/ Почистете/сменете аератора
/ Трудно подвижна арматура	/ Дефектна гилза, покрита с варовик	/ Сменете гилзата
/ Арматурата капе	/ Дефектна гилза	/ Сменете гилзата
/ Избиване на вода от закрепващата шийка	/ Свързващите маркучи не са напълно завинтени в основното тяло	/ Затегнете на ръка свързващите маркучи
	/ Дефектен О-образен пръстен на свързващия маркуч	/ Смяна на О-образен пръстен
/ Твърде ниска температура на водата	/ Ограничението за топлата вода е грушно настроено	/ Настройте ограничението за топлата вода

МОНТАЖ (вижте стр. 32)



△ UDHËZIME SIGURIE

- △ Për të evituar lëndimet e pickimeve ose të prerjeve gjatë procesit të montimit duhet që të vishni doreza.
- △ Ndryshimet e mëdha të presionit mes lidhjeve të ujit të ftohtë dhe atij të ngrohtë duhen ekuilibruar.

UDHËZIME PËR MONTIMIN

- / Përpara montimit duhet që produkti të kontrollohet për dëmtime nga transporti. Pas instalimit nuk do të njihet asnjë dëmtim nga transporti ose dëmtim i sipërfaqes.
- / Tubacionet dhe rubinetet duhet që të montohen, të shpëlahen dhe të kontrollohen sipas standardeve në fuqi
- / Duhet të respektohen linjat udhëzuese të instalimit, të vlefshme për vendet respektive.
- / 39853000: Armatura nuk mund të përdoret në kombinim me një ngrohës elektrik të ujit.

TË DHËNA TEKNIKE

Presioni gjatë punës	maks. 1 MPa
Presioni i rekomanduar:	0,1 - 0,5 MPa
Presioni për provë:	1,6 MPa
	(1 MPa = 10 bar = 147 PSI)
Temperatura e ujit të ngrohtë	maks. 70°C
Temperatura e rekomanduar e ujit të ngrohtë:	65°C
Dezinfektim Termik:	maks. 70°C / 4 min
Produkti është projektuar ekskluzivisht për ujë të pijshëm!	

PËRSHKRIMI I SIMBOLIT



Mos përdorni silikon që në përbërje ka acid acetik.



JUSTIMI (shih faqen 36)

Regullimi i kufizimit me ujë të nxehtë. Një kombinim me një bojler ujit nuk është i rekomanduar.



PËRMASAT (shih faqen 42)

DEMTIM

- / Pak ujë
- / Armatura punon rende
- / Armatura pikon
- / Dalje e ujit ne cilindrin fiksues
- / Temperaturë e ulët e ujit të ngrohtë

SHKAKU

- / Shperndaresi i ajrit me kalk, me papasterti
- / Kartusha me defekt, me kalk
- / Kartusha me defekt
- / Tubat e lidhjes jo komplet te vidhosur ne karkasen baze
- / Unaza O tek tubi lidhes me defekt
- / Kufiri i ujit te ngrohte eshte regjistruar gabim

NDIHME

- / Pastroni shperndaresin e ajrit/kembejeni
- / Kembeni kartushen
- / Kembeni kartushen
- / Shtrengojini manualisht tubat e lidhur
- / Kembeni unazen O
- / Regjistroni kufirin e ujit te ngrohte



DIAGRAMI I QARKULLIMIT

(shih faqen 42)



PJESËT E SERVISIT (shih faqen 44)

- XXX = Kodimi me anë të ngjyrave
- 000 = Krom
- 020 = Polished Chrome
- 130 = Polished Bronze
- 140 = Brushed Bronze
- 250 = Brushed Gold-Optic
- 260 = Brushed Chrome
- 300 = Polished Redgold
- 310 = Brushed Redgold
- 330 = Polished Black Chrome
- 340 = Brushed Black Chrome
- 800 = Stainless Steel Optic
- 820 = Brushed Nickel
- 830 = Polished Nickel
- 930 = Polished Brass
- 950 = Brushed Brass
- 990 = Polished Gold-Optic

PAJISJE TË POSAÇME

(nuk përfshihet në vëllimin e furnizimit)



Përshtatësi (G¹/₂/G³/₄) #93395000 (shih faqen 45)



PASTRIMI (shih faqen 38)



PËRDORIMI (shih faqen 37)

Hansgrohe rekomandon që në mëngjes ose pas periudhave të gjata që gjysmë litri i parë mos të pihet



SHENJA E KONTROLLIT

(shih faqen 43)



⚠ تنبيهات الأمان

- ⚠ يجب إرتداء قفازات الليد أثناء التركيب لتجنب حدوث أضرار الإنحشار أو الجروح
- ⚠ يجب أن يكون تيار الماء الساخن والماء البارد متعادلين في الضغط

تعليمات التركيب

- / قبل القيام بعملية التركيب، يجب فحص المنتج للتأكد من خلوه من أية تلفيات ناتجة عن النقل بعد القيام بعملية التركيب، لن يتم الاعتراف بوجود أية تلفيات سطحية أو تلفيات ناتجة عن عملية النقل.
- / يجب تركيب وغسيل واختبار التوصيلات وخلطات المياه طبقاً للمعايير السارية.
- / يجب مراعاة القواعد الخاصة بالتركيب وأعمال السباكة وفقاً للوائح الخاصة بكل بلد.
- / 39853000: لا يمكن استخدام خلط الماء مع جهاز تسخين الماء الفوري

المواصفات الفنية

- ضغط التشغيل: الحد الأقصى 1 ميجاباسكال
- ضغط التشغيل الموصى به: 0,5 - 0,1 ميجاباسكال
- ضغط الاختبار: 1,6 ميجاباسكال
- (1 ميجاباسكال = 10 بار = 147 PSI)
- درجة حرارة الماء الساخن: الحد الأقصى 70°C
- درجة الحرارة الموصى بها للماء الساخن: 65°C
- تعقيم حراري: الحد الأقصى 4/70°C الدقيقة
- المنتج مخصص فقط لماء الشرب!

وصف الرمز

هام! لا تستخدم السليكون الذي يحتوي على أحماض! 

الضبط (راجع صفحة 36) 

ضبط تحديد المياه الدافئة. لا ينصح باستخدام محدد المياه الدافئة مع سخان المياه الوتقي.

أبعاد (راجع صفحة 42) 

رسم للصراف (راجع صفحة 42)



قطع الغيار (راجع صفحة 44)



الألوان = XXX

كروم = 000

Polished Chrome = 020

Polished Bronze = 130

Brushed Bronze = 140

Brushed Gold-Optic = 250

Brushed Chrome = 260

Polished Redgold = 300

Brushed Redgold = 310

Polished Black Chrome = 330

Brushed Black Chrome = 340

Stainless Steel Optic = 800

Brushed Nickel = 820

Polished Nickel = 830

Polished Brass = 930

Brushed Brass = 950

Polished Gold-Optic = 990

ملحقات خاصة

(غير مدرج مع المحتويات المسلمة)

محول #93395000 (G^{1/2} / G^{3/4})

(راجع صفحة 45)

التنظيف (راجع صفحة 38)

التشغيل (راجع صفحة 37)

تتصح شركة هانز جروهي Hansgrohe بعدم استخدام أول نصف لتر من الماء لغرض الشرب وذلك في الصباح أو بعد توقف استخدام الماء لفترات طويلة نسبياً.

شهادة اختبار (راجع صفحة 43)



العلاج والإصلاح

السبب

العطل

/ الماء غير كافٍ / خلط الهواء متراكم عليه الجير / قم بتنظيف / تغيير خلط الهواء

/ الخلط ثقيل الحركة / الخرطوشة تالفة، تراكم عليها الجير / قم بتغيير الخرطوشة

/ تساقط قطرات مياه من الخلط / الخرطوشة تالفة / قم بتغيير الخرطوشة

/ خروج الماء من جزء التثبيت / خرطوم التوصيل ليست مربوطة في / اربط خرطوم التوصيل بيدك الجزء الرئيسي بشكل كامل

/ الحلقة الدائرية الخاصة بخرطوم التوصيل تالفة / الحلقة الدائرية الخاصة بخرطوم / قم بتغيير الحلقة الدائرية

/ درجة حرارة الماء الساخن منخفضة / محدد الماء الساخن مضبوط بشكل خاطيء / قم بضبط محدد الماء الساخن للغاية



التركيب (راجع صفحة 32)

△ BIZTONSÁGI UTASÍTÁSOK

- △ A szerelésnél a zúzódások és vágási sérülések elkerülése érdekében kesztyűt kell viselni.
- △ A hidegvíz- és melegvíz-csatlakozások közötti nagy nyomáskülönbséget kikell egyenlíteni!

SZERELÉSI UTASÍTÁSOK

- / A szerelés előtt ellenőrizni kell, hogy a terméknek nincs-e szállítási sérülése. Beépítés után a szállítási- vagy felületi sérüléseket nem ismerik el.
- / A vezetékeket és a csaptelepet az érvényes szabványoknak megfelelően kell felszerelni, öblíteni és ellenőrizni
- / Az egyes országokban érvényes installációs irányelveket be kell tartani.
- / 39853000: A vízcsapot nem lehet átfolyós vízmelegítővel használni.

MŰSZAKI ADATOK

Üzemi nyomás:	max. 1 MPa
Ajánlott üzemi nyomás:	0,1 - 0,5 MPa
Nyomáspróba:	1,6 MPa
	(1 MPa = 10 bar = 147 PSI)
Forróvíz hőmérséklet:	max. 70°C
Forróvíz javasolt hőmérséklete:	65°C
Termikus fertőtlenítés:	max. 70°C/4 perc

A terméket kizárólag ivóvízhez tervezték!

SZIMBÓLUMOK LEÍRÁSA



Ne használjon ecetsavtartalmú szilikon!



BEÁLLÍTÁS (lásd a oldalon 36)

A meleg víz korlátozás beállítása. Átfolyós vízmelegítőknél meleg víz korlátozó használata nem ajánlott.



MÉRETET (lásd a oldalon 42)



ÁTFOLYÁSI DIAGRAMM
(lásd a oldalon 42)



TARTOZÉKOK (lásd a oldalon 44)

- XXX = Szinkódolás
- 000 = Króm
- 020 = Polished Chrome
- 130 = Polished Bronze
- 140 = Brushed Bronze
- 250 = Brushed Gold-Optic
- 260 = Brushed Chrome
- 300 = Polished Redgold

- 310 = Brushed Redgold
- 330 = Polished Black Chrome
- 340 = Brushed Black Chrome
- 800 = Stainless Steel Optic
- 820 = Brushed Nickel
- 830 = Polished Nickel
- 930 = Polished Brass
- 950 = Brushed Brass
- 990 = Polished Gold-Optic

EGYÉB TARTOZÉK

(a szállítási egység nem tartalmazza)



Adapter (G $\frac{1}{2}$ / G $\frac{3}{4}$) #93395000
(lásd a oldalon 45)



TISZTÍTÁS (lásd a oldalon 38)



HASZNÁLAT (lásd a oldalon 37)

- / A csaptelepeken átfolyt víz hőmérséklete fogyasztásra szánt víz esetében a 65°C-ot nem haladhatja meg. A csaptelep nem eredményezheti az emberi fogyasztásra (pl. ivás és főzés céljából) szánt víz minőségromlását.
- / Beüzemelés és üzemszünetek után szigorúan be kell tartani a használati útmutatóban leírtakat. Beüzemeléskor a csaptelepet át kell öblíteni, legalább 2 percig törtéző hideg- és melegvízes folyatást javasunk. Minimum 1 napos üzemszünet után fogyasztás előtt a csaptelepben stagnáló hideg- illetve melegvíz fogyasztása nem javasolt, a csaptelepben stagnáló vizet ki kell engedni, legalább 2 perces folyatás javasolt. A kifolyatás során nyert vizet ivóvízként, illetve ételkészítési céllal felhasználni nem szabad.
- / Tekintettel arra, hogy a forró víz fémoldó képessége a hideg vizénél nagyobb, emiatt főzés ivás céljából az OKI a hideg víz használatát javasolja.
- / A csaptelepek perlatorát javasolt havonta vízköteníteni, illetve fertőtleníteni. A csaptelepek tisztítása, fertőtlenítése során kizárólag olyan vegyszer alkalmazható, amely megfelel a 201/2001. (X.25) Kormányrendelet, illetve a 38/2003. (VII.7) ÉSZCsM-FVM-KvVM együttes rendeletben leírtaknak.

- / A perlátor működési elvéből adódóan jelentős aeroszolt képez, így Legionella expozíció szempontjából fokozott kockázatot jelent. Ezért alkalmazása nem javasolt az egészségügyi intézmények fekvőbeteg ellátó szobáiban, illetve minden olyan helyen, ahol a hideg és/vagy használati melegvíz Legionella csíraszámja eléri a 49/2015 (XI.6.) EMMI rendelet alapján meghatározott beavatkozási szintet.



VIZSGAJEL (lásd a oldalon 43)

HIBA	OK	MEGOLDÁS
/ Kevés víz	/ A perlátor elvzikkövesedett, elszennyeződött	/ A perlátort megtisztítani/kicserélni.
/ Nehezen nyitható a csap.	/ A kerámiabetét meghibásodott, elvzikkövesedett.	/ A kerámiabetétet ki kell cserélni.
/ Csöpög a csap.	/ A kerámiabetét meghibásodott.	/ A kerámiabetétet ki kell cserélni.
/ Vízkilépés a rögzítőrúdon	/ A csatlakozótömlők nincsenek teljesen becsavarozva az akaptestbe / Csatlakozótömlő tömítőgyűrűje meghibásodott	/ A csatlakozótömlőket kézzel meghúzni / Tömítőgyűrű kicserélése
/ túl alacsony melegvíz hőmérséklet	/ A melegvíz szabályozó rosszul van beállítva.	/ A melegvíz szabályozót újra be kell állítani.



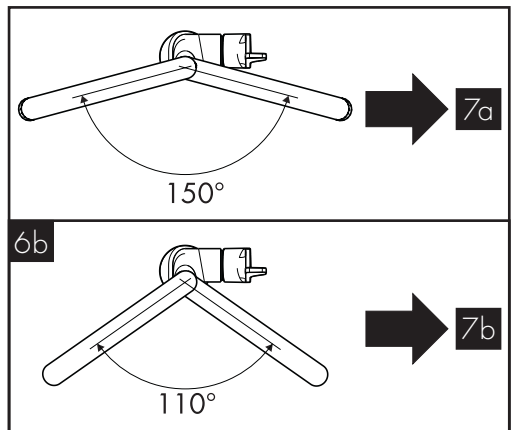
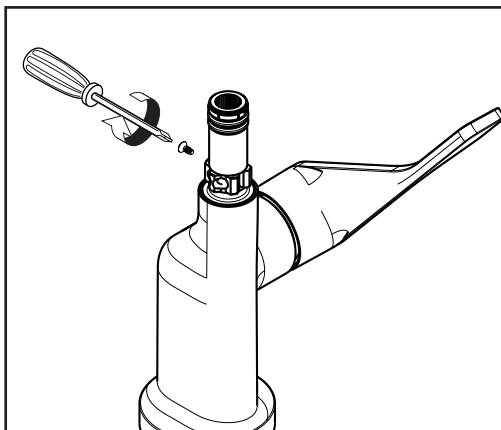
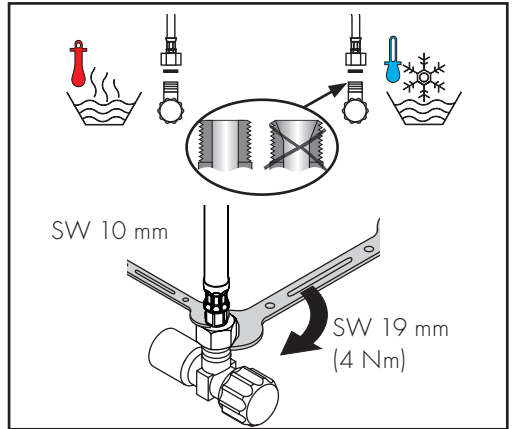
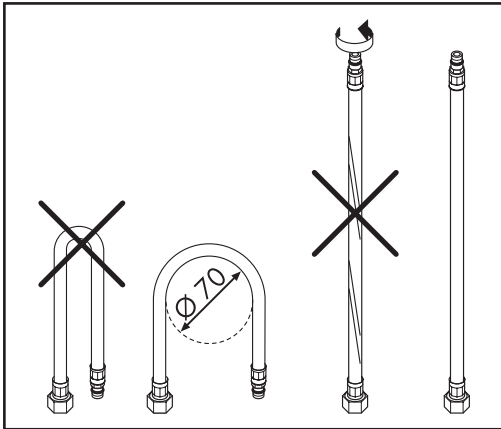
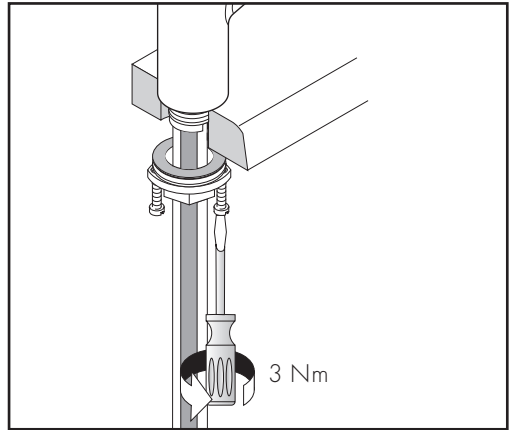
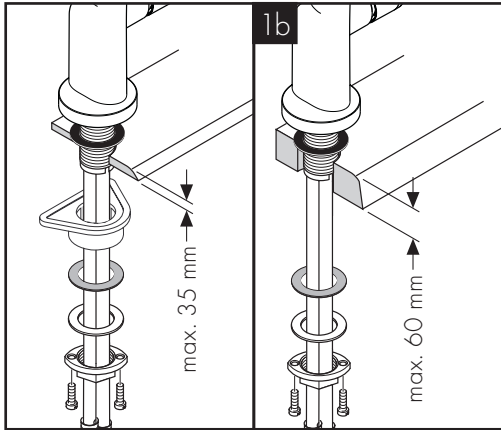

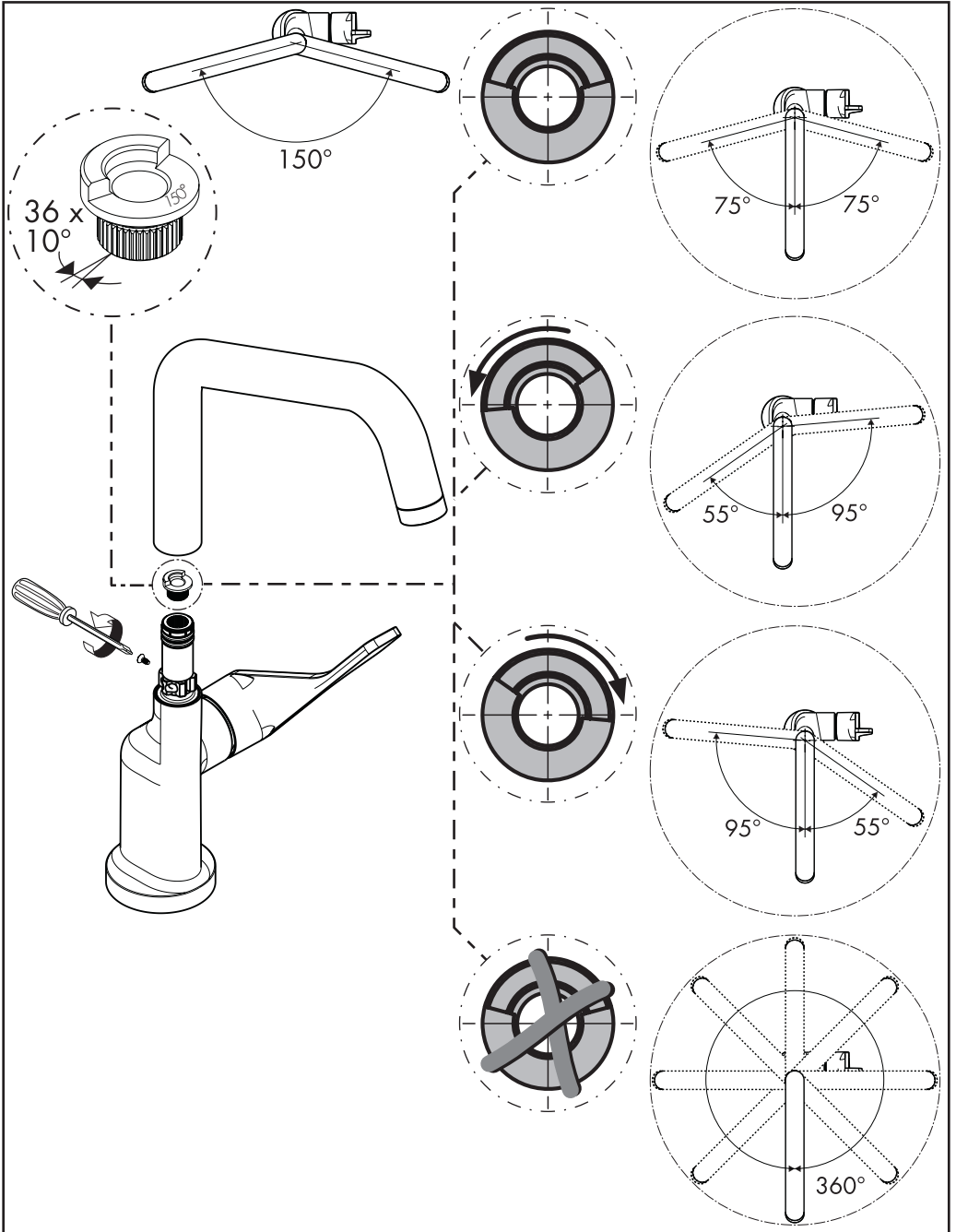



7b

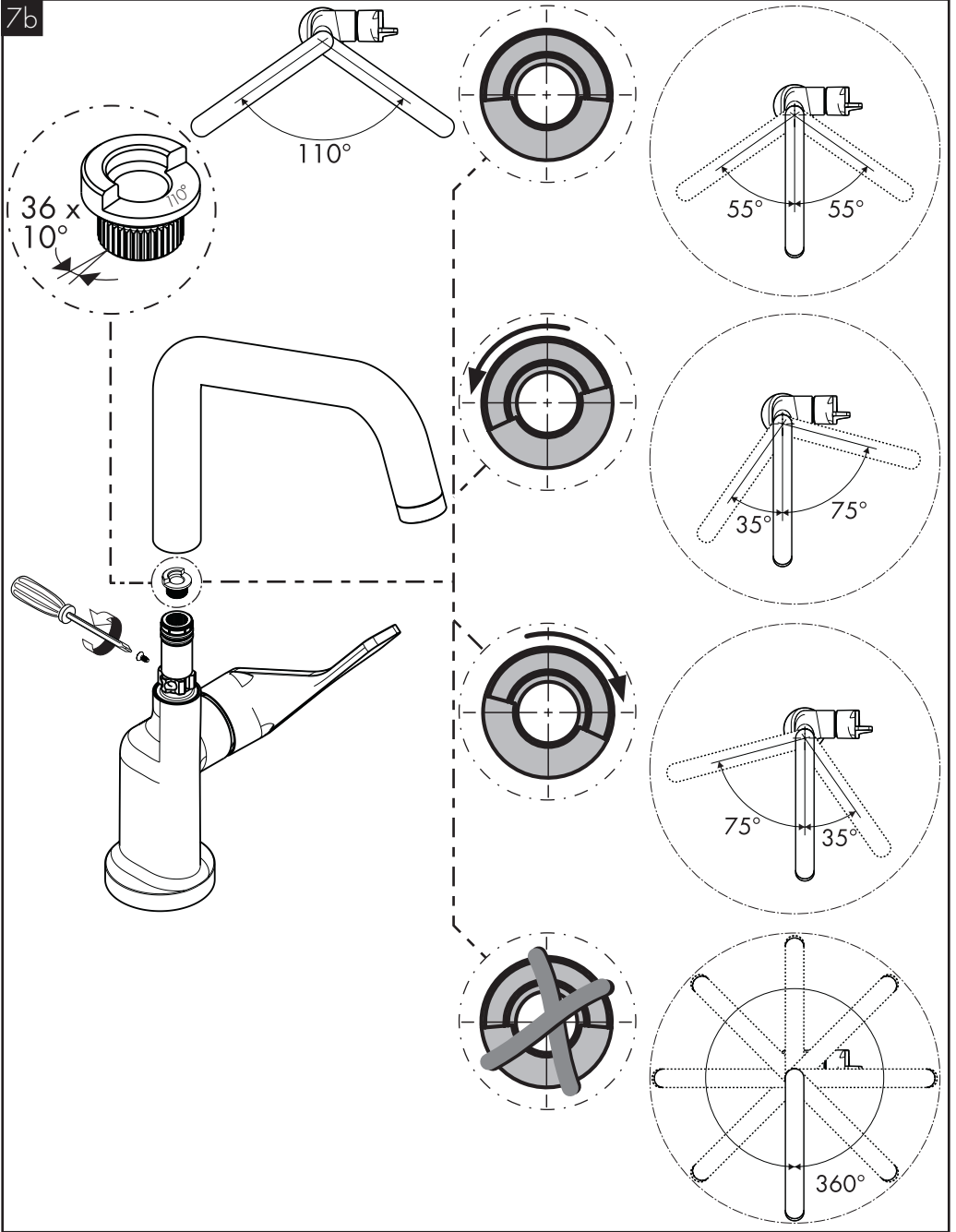

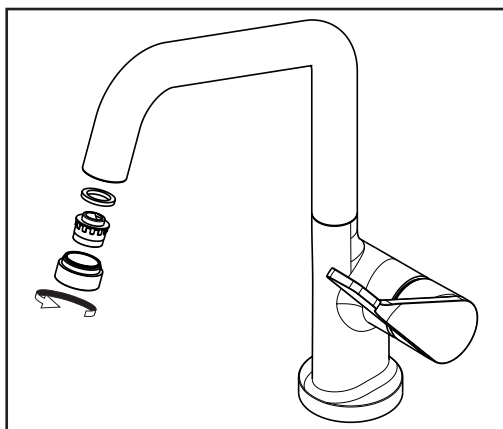
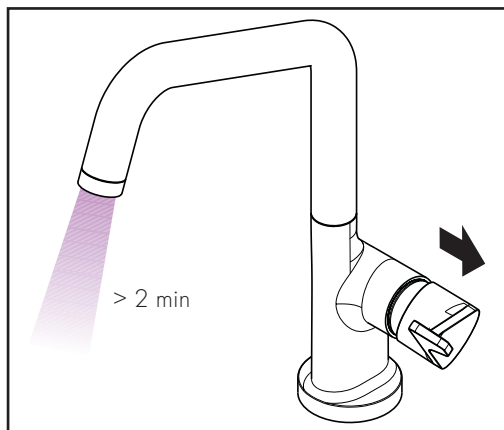
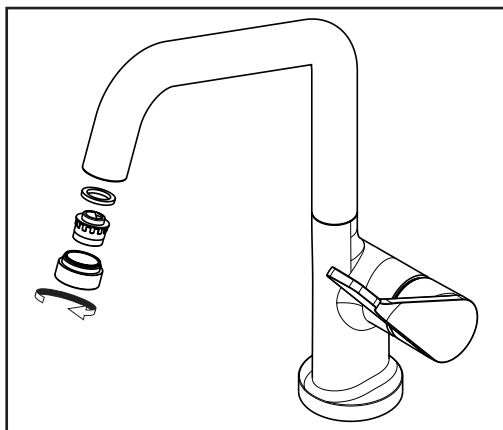

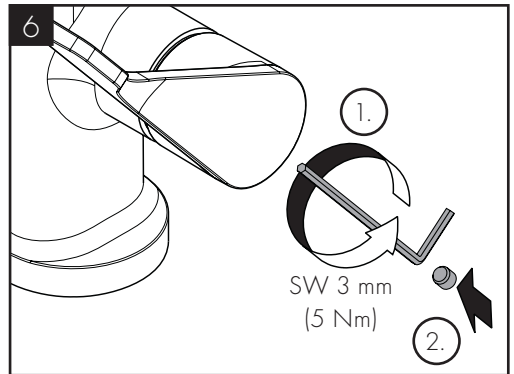
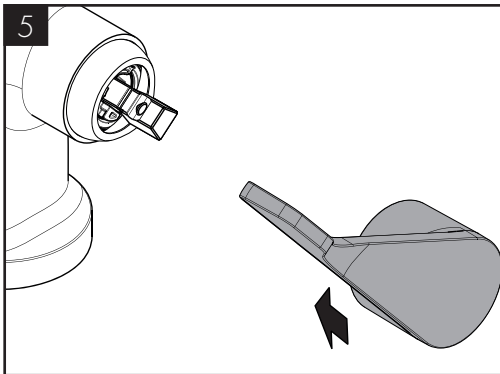
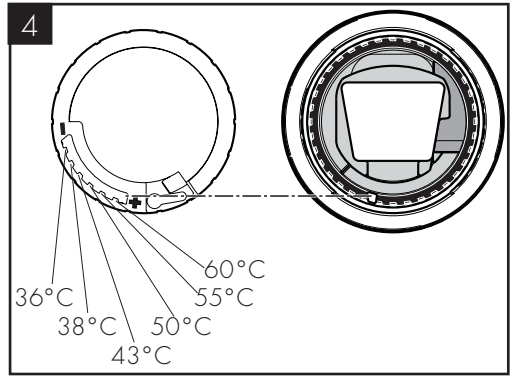
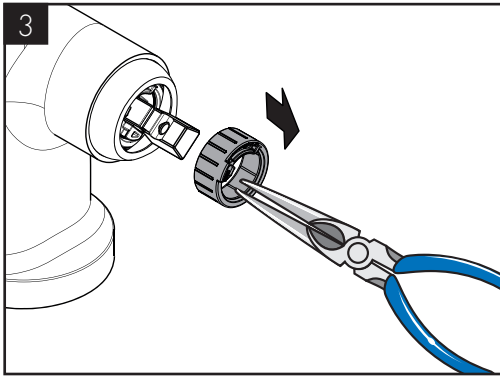
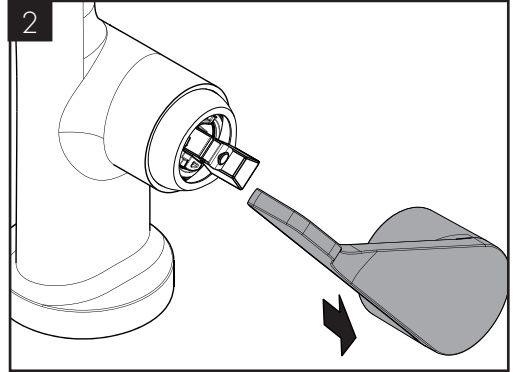
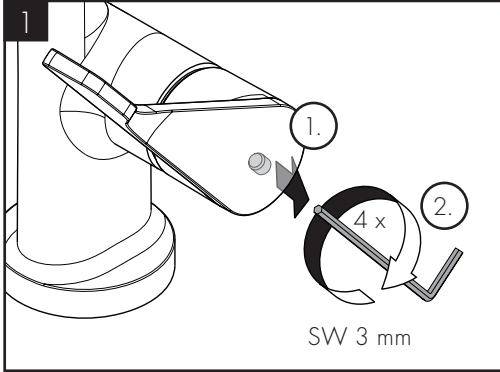

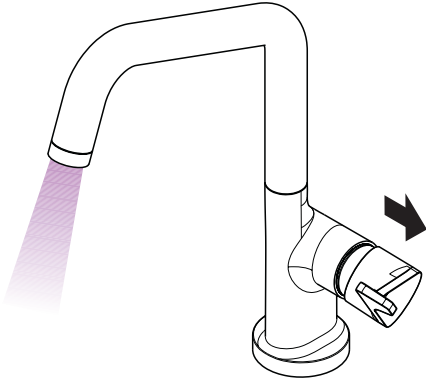

öfnnen / ouvert / open / aperto / abierto / open / åbne / abrir /
 otworzyć / otevřít / otvorit / 开 / открыть / nyitás /
 αναμινεν / öppna / atidaryti / Otvaranje / açmak /
 deschide / ανοικτό / odpreti / avage / atvērt / otvoriti / åpne /
 отваряне / hare / فتح

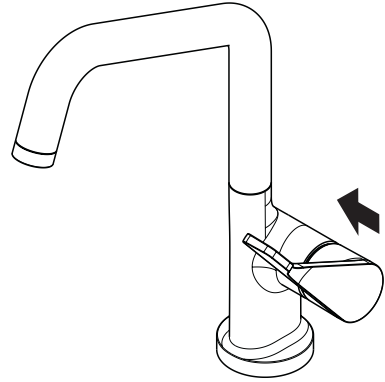

schließen / fermé / close / chiudere / cerrar / sluiten / lukke /
 fechar / zamknąć / zavřít / uzavrieť / 关 / закрыть / bezárás /
 sulkeminen / stänga / uždaryti / Zatvaranje / kapatmak /
 închide / κλειστό / zapreti / sulgege / aizvērt / zatvori / lukke /
 затваряне / mbylle / إغلاق

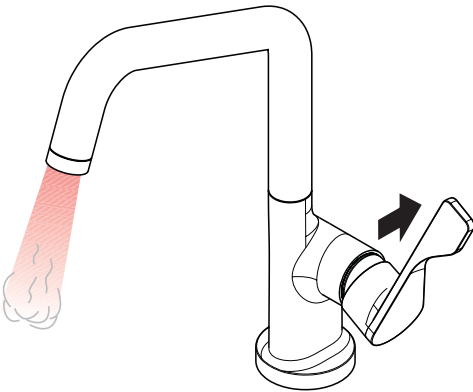

warm / chaud / hot / caldo / caliente / varm / varmt / quente /
 ciepła / teplá / teplá / 热 / горячая / meleg / lämmin / varmt /
 karštas / Vruća voda / sıcak / cald / ζεστό / toplo / kuum /
 karsts / topla / varm / тепло / i ngrohtë / ساخن

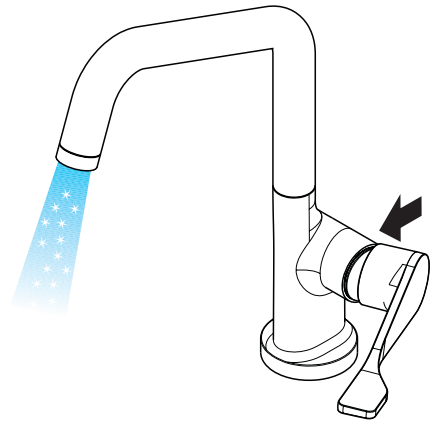

kalt / froid / cold / freddo / frío / koud / koldt / fría / zimna /
 studená / studená / 冷 / холодная / hideg / kylmä / kallt /
 šaltas / Hladno / soğuk / rece / κρύο / mrzlo / külm / auksts /
 hladno / kaldt / студено / i ftohtë / بارد



- DE / Reinigungsempfehlung / Garantie / Kontakt
 FR / Recommandation pour le nettoyage / Garanties / Contact
 EN / Cleaning recommendation / Warranty / Contact
 IT / Raccomandazione di pulizia / Garanzia / Contatto
 ES / Recomendaciones para la limpieza / Garantía / Contacto
 NL / Aanbevelingen inzake reiniging / Garantie / Contact
 DK / Rensning, anbefaling / Garanti / Kontakt
 PT / Recomendações de limpeza / Garantia / Contacto
 PL / Zalecenie dotyczące pielęgnacji / Gwarancja / Kontakt
 CS / Doporučení k čištění / Záruka / Kontakt
 SK / Odporúčania pre čistenie / Záruka / Kontakt
 ZH / 清洁指南 / 担保 / 接触
 RU / Рекомендации по очистке / Гарантия / Контакты
 HU / Tisztítási tanácsok / Garancia / érintkezés
 FI / Puhdistussuositus / Takuu / Kosketus
 SV / Rengöringsrekommendationer / Garanti / Contacto
 LT / Valymo rekomendacijos / Garantija / Kontaktai
 HR / Preporuke za čišćenje / Garancija / Kontakt
 TR / Temizleme önerisi / Garanti / Temas
 RO / Recomandări pentru curățare / Garanție / Contact
 EL / Σύσταση καθαρισμού / Εγγύηση / επαφή
 SL / Priporočilo za čišćenje / Garancija / Kontakt
 ET / Puhastussuovitused / Garantii / Kontakt
 LV / Tīrīšanas ieteikumi / Garantija / Kontakti
 SR / Preporuke za čišćenje / Garancija / Kontakt
 NO / Anbefaling for rengjøring / Garanti / Kontakt
 BG / Препоръка за почистване / Гаранция / Контакт
 SQ / Këshilla rreth pastrimit / Garancia / Kontakt
 KO / 세정시 권장사항 / 품질보증 / 접촉
 AR / توصيات التنظيف / الضمان (الولايات المتحدة الأمريكية) / اتصال



[www.axor-design.com/
cleaning-recommendation](http://www.axor-design.com/cleaning-recommendation)



[www.axor-design.com/
cleaning-recommendation](http://www.axor-design.com/cleaning-recommendation)



[www.axor-design.com/
cleaning-recommendation](http://www.axor-design.com/cleaning-recommendation)



[www.axor-design.com/
cleaning-recommendation](http://www.axor-design.com/cleaning-recommendation)



EcoSmart®
93507000

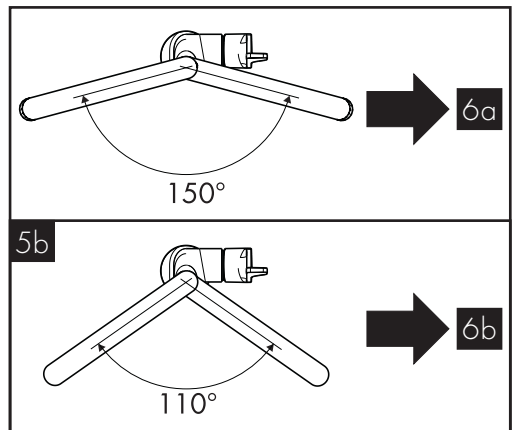
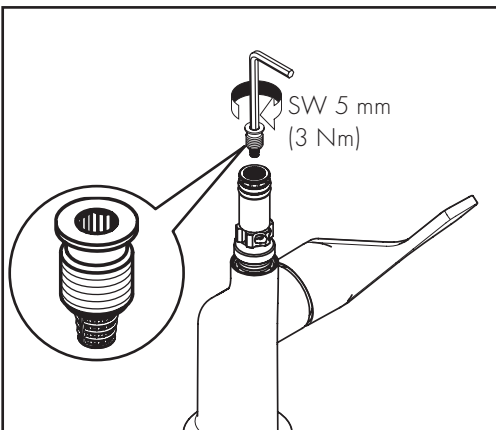
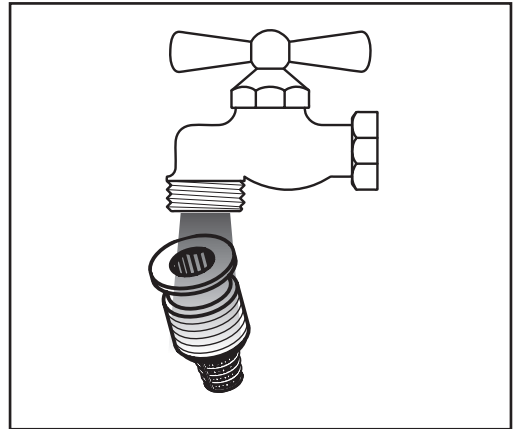
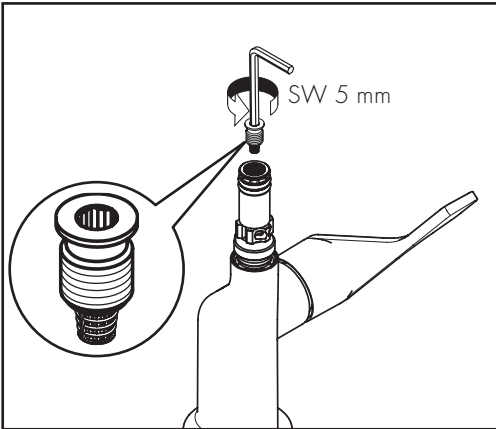
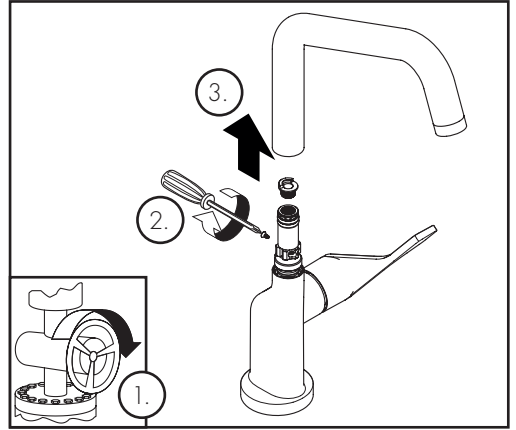

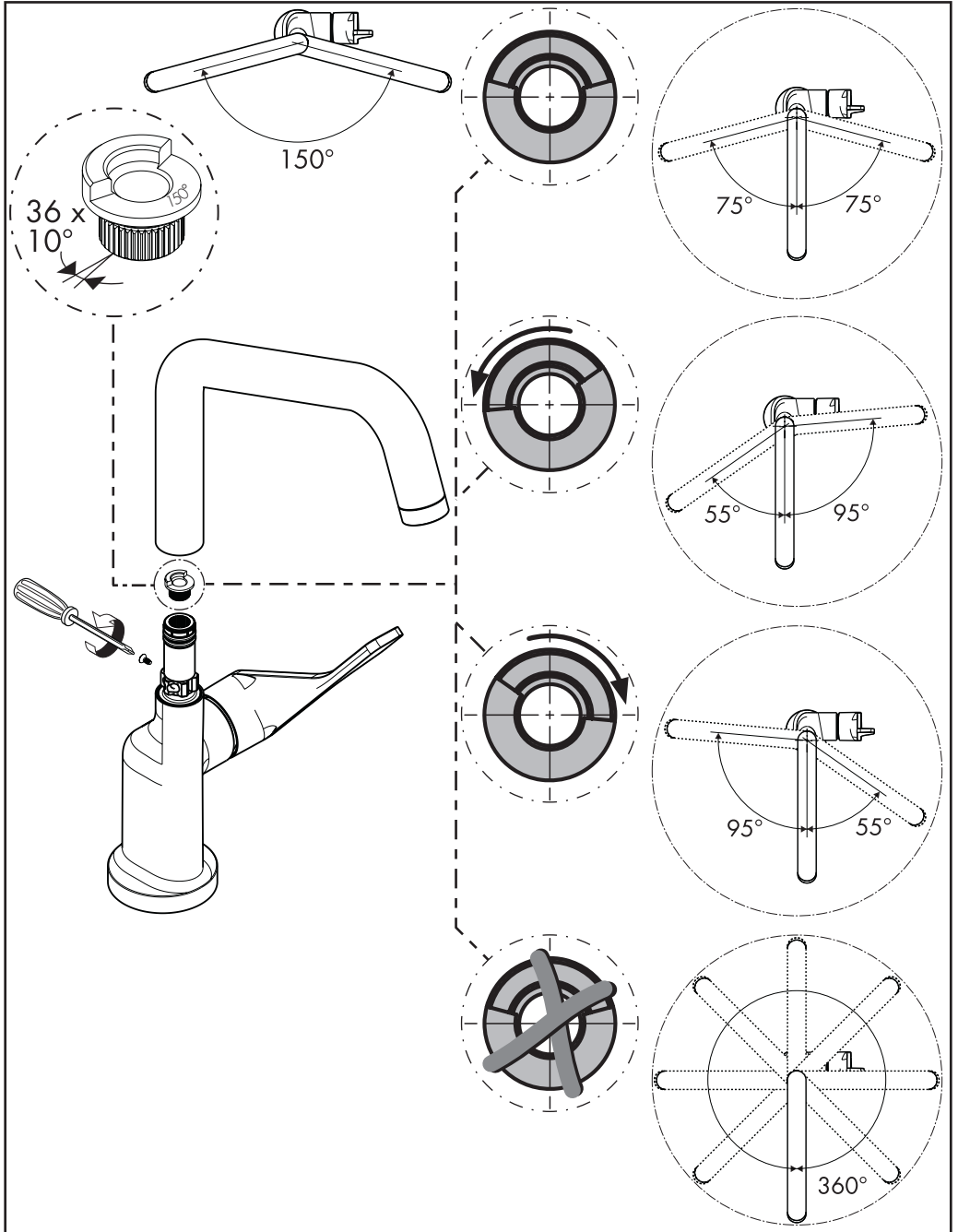



6b

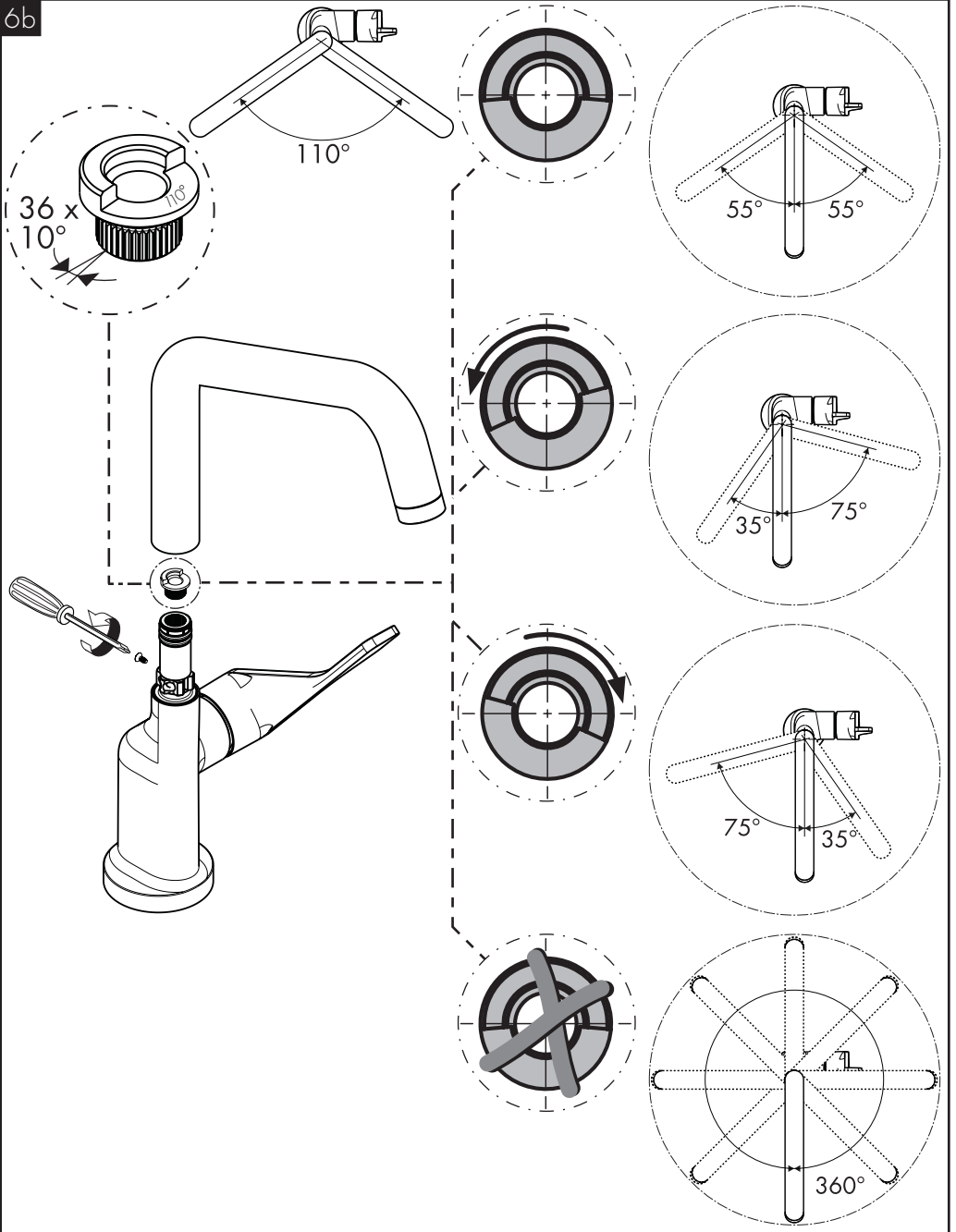



AXOR Citterio
39850XXX

AXOR Citterio Eco
39853000

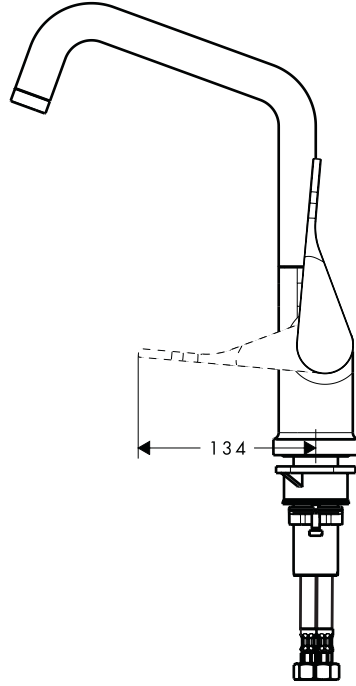
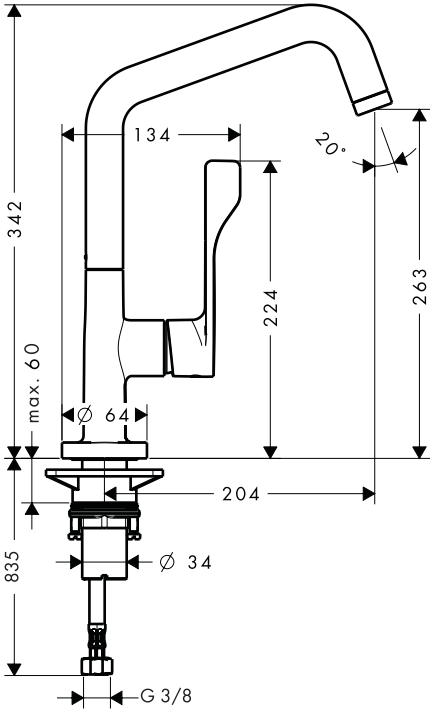

AXOR Citterio
39850XXX

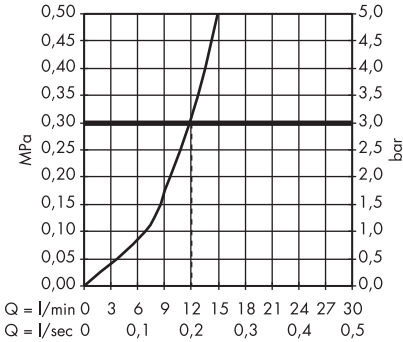

AXOR Citterio Eco
39853000

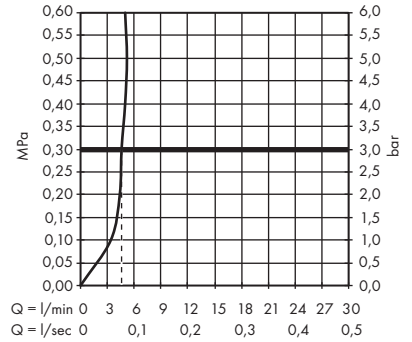



P-IX

DVGW

SINTEF

NF



ETA

GODKENDT
TIL DRIKKEVAND

39850XXX

P-IX 18330/1B

BT0603

X

X

X

39853000





AXOR Citterio
39850XXX

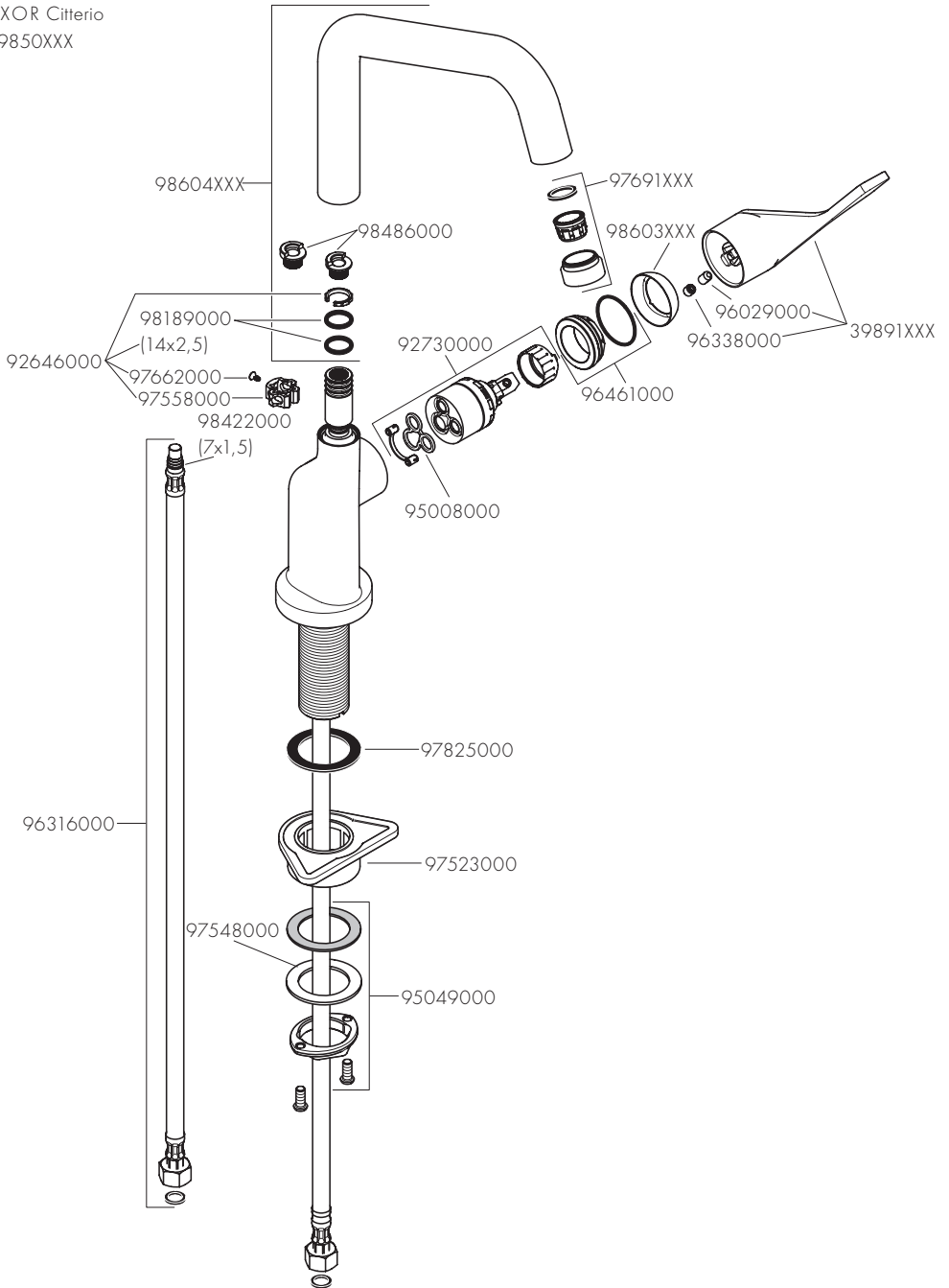



AXOR Citterio Eco
39853000

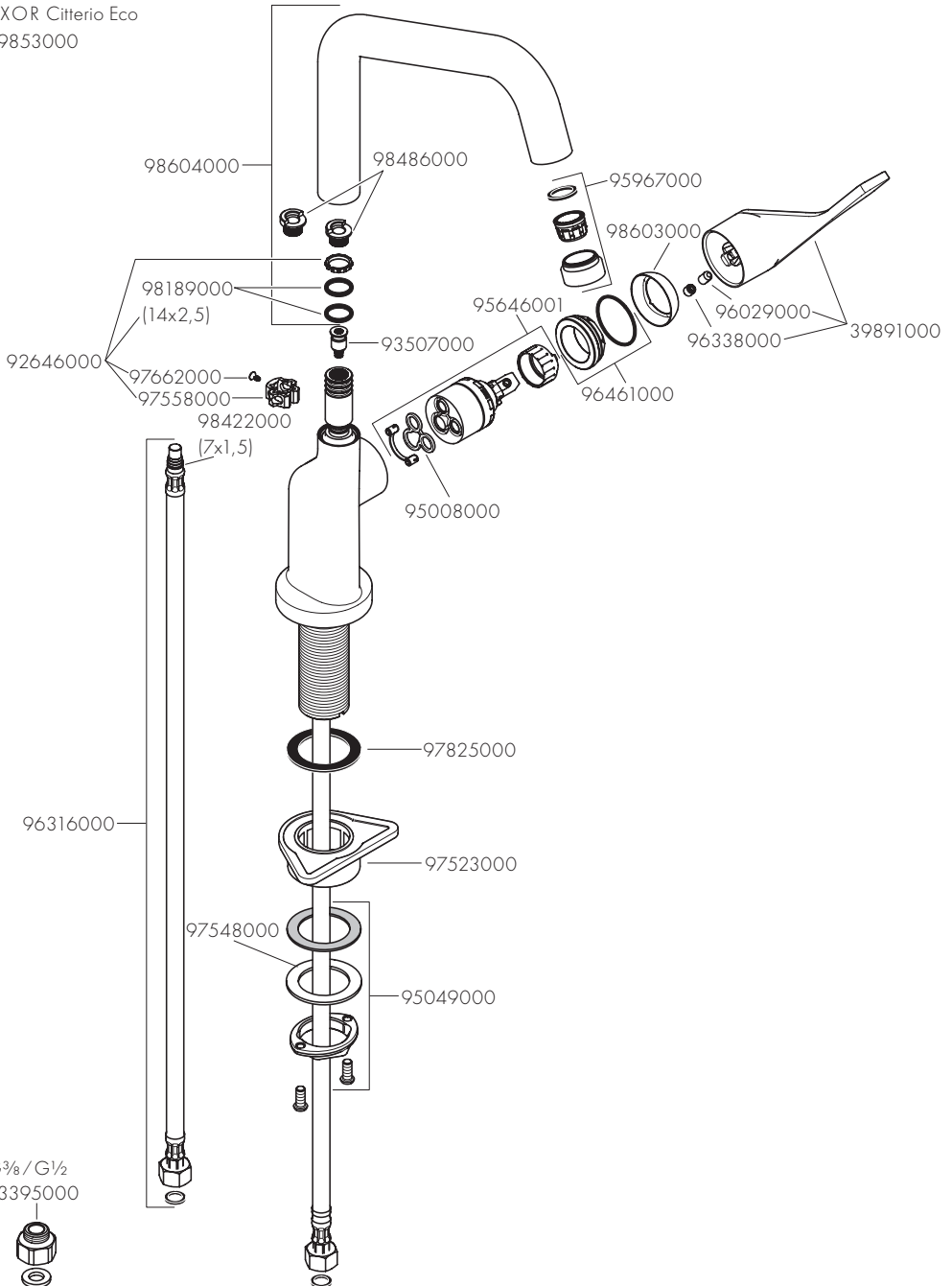

AXOR

AXOR / Hansgrohe SE
Austraße 5-9
77761 Schiltach
Deutschland

info@axor-design.com
axor-design.com

12/2019
9.05885.04