

NOVOHALL
Angle Sensor
non-contacting

Series RSC2800
analog



Special features

- non-contacting, magnetic
- electrical range up to 360°
- available with push-on coupling or marked shaft
- simple mounting
- protection class IP54, IP65, IP67
- long life
- very small hysteresis
- internal resolution 12 Bit
- independent linearity $\pm 0.5\%$
- single and redundant versions
- versions with digital interface see separate data sheet

The contactless sensor utilizes the orientation of a magnetic field for the determination of the measurement angle.

The magnetic field orientation is captured with an integrated circuit. An analogue output signal represents the calculated angle.

The housing is made of a special high grade temperature-resistant plastic material.

Fixings are in the form of elongated slots which allow simplicity in mounting together with ease of mechanical adjustment.

The special backlash-free push-on coupling ensures extremely quick and simple installation. The transducer is not sensitive to either dirt or humidity.

Electrical connection is made via a shielded cable which is sealed into the housing, M12 connector on request.

Description

Housing	high grade, temperature resistant plastic
Shaft	stainless steel
Bearings	bronze sleeve bearing
Electrical connections	shielded cable AWG26 (0.14 mm ²) M12 connector

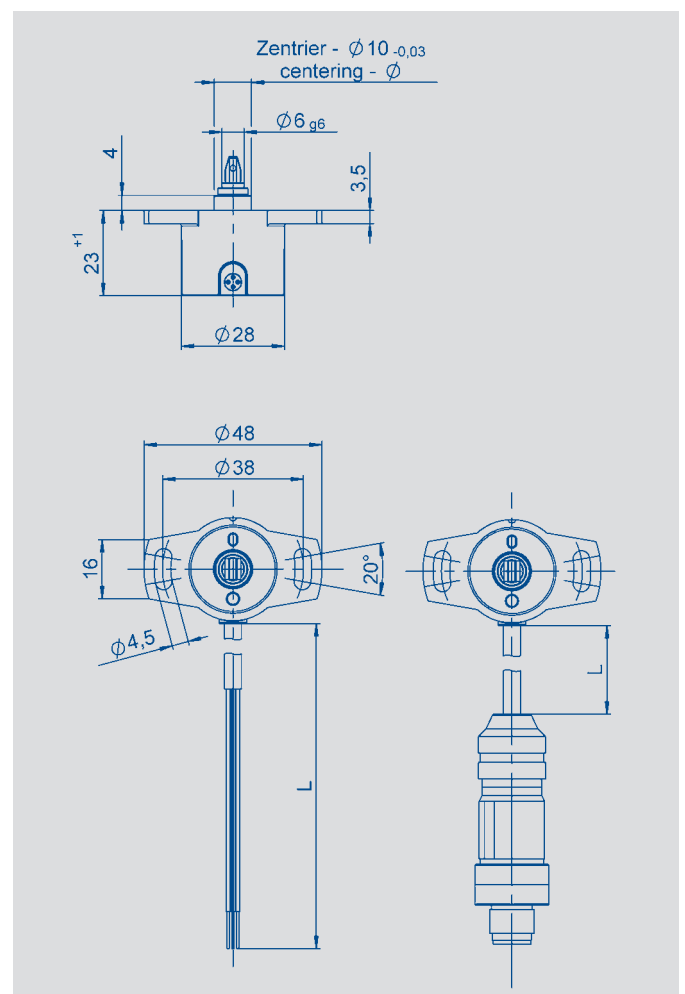

Output characteristic one-channel versions

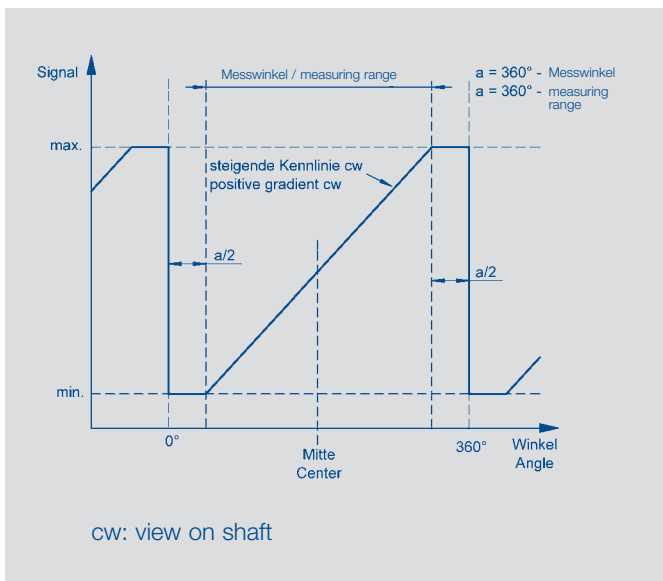

Output characteristics multi-channel versions

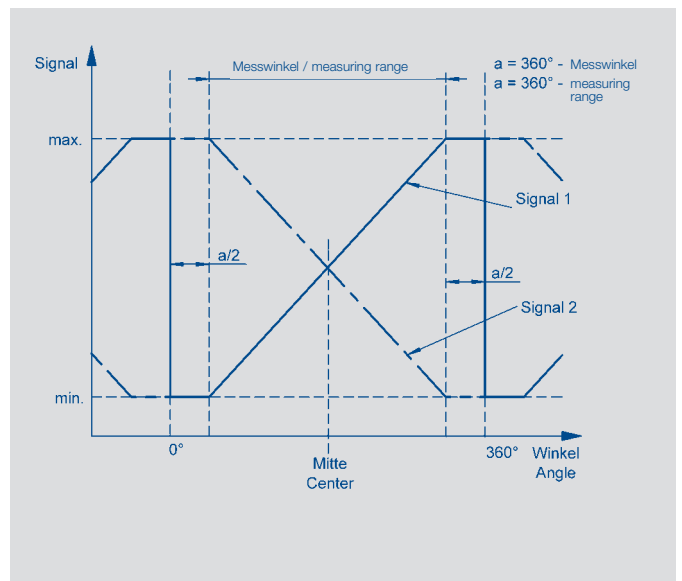

Shaft designs

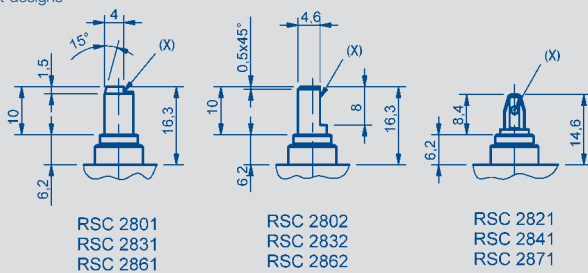

Recommended dimensions of driving shaft
for RSC2821 / RSC2841 / RSC2871
Parallel offset < 0.05 mm.

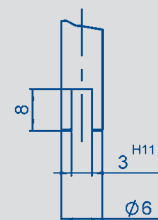

Recommended hole pattern
2 x Ø 4,3 or 2 x M4

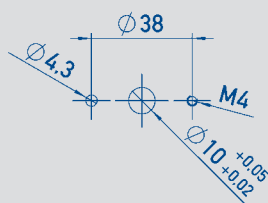

When the shaft marking is pointing to cable, the sensor is located in an electrical center position.

	M12 connector	cable
Ground	3	brown
Supply voltage	1	green
Output	2	white
Not assigned / output 2	4	yellow

Cable shielding connect to ground.

Type designations	RSC - 28 ratiometric	RSC - 28 voltage	RSC - 28 current	
Mechanical Data				
Dimensions	see dimension drawing			
Mounting	with 2 M4 screws and washer			
Starting torque of mounting clamps at housing flange	400			Ncm
Mechanical travel	360 continuous			°
Permitted shaft loading (axial and radial) static or dynamic force	20			N
Torque	1.0 (IP67); 0.5 (IP65); 0.15 (IP54)			Ncm
Maximum operational speed	120			min ⁻¹
Weight	ca. 50			g
Electrical Data				
Supply voltage Ub	5 (4.5 ... 5.5)	24 (18 ... 30)	24 (18 ... 30)	VDC
Current consumption (w/o load)	typical 15 (typ. 8 on request) per channel			mA
Reverse voltage	yes, only supply lines			
Short circuit protection vs. GND and Ub	yes	yes	yes	
Measuring range	0 ... 30 up to 0 ... 360, in 10° steps			°
Number of channels	1 / 2	1	1	
Update rate	5000 typ.			measur/s
Resolution	12 bit			
Repeatability	0,1			°
Hysteresis	< 0,1			°
Independent linearity	≤ 0,5 of signal range			%
Output signal	ratiometric to Ub 0.25...4.75 V 0.5...4.5 V (load ≥1 kΩ)	0,1...10 V (load ≥10 kΩ)	4...20 mA (burden max. 500 Ω)	
TC at measuring range 30 up to 170°	typ. 100	typ. 150	typ. 150	ppm/K
TC at measuring range 180 up to 360°	typ. 50	typ. 80	typ. 80	ppm/K
Insulation resistance (500 VDC)	≥ 10			MΩ
Cross-section cable	approx. 0.14			mm ²
Environmental Data				
Temperature range	-40...+85 (generally -25...+85 with M12 connector)			°C
Vibration (IEC 60068-2-6)	5...2000 A _{max} = 0.75 a _{max} = 20			Hz mm g
Shock (IEC 60068-2-27)	50 (6 ms)			g
Life	mechanically unlimited			
MTTF	290 (single) 209 (partially redundant)	98	111	years years
Protection class (DIN EN 60529)	IP67 / IP65 / IP67			
EMC compatibility	EN 61000-4-2 electrostatic discharges (ESD): 4kV, 8kV EN 61000-4-3 electromagnetic fields: 10V/m EN 61000-4-4 electrical fast transients (burst): 1kV EN 61000-4-6 conducted disturbances, induced by RF fields: 10V/m eff. EN 61000-4-8 power frequency magnetic fields: 3A/m EN 55011/EN 55022/A1 radiated disturbances: class B			



Ordering specifications

Preferred types printed in bold:

- delivery time up to 25 pcs. within 10 working days
- no low volume surcharge

Operating voltage U_b
 1: $U_b = 24\text{ V}$ (18 ... 30 V)
 2: $U_b = 5\text{ V}$ (4.5 ... 5.5 V)

Output signal $U_b = 24\text{ V}$
 1: 0.1 ... 10 V
 2: 4 ... 20 mA

Output signal $U_b = 5\text{ V}$
 1: 0.25 ... 4.75 V ratiometric to U_b
 2: 0.5 ... 4.5 V ratiometric to U_b

Output characteristics

- 1: rising CW
- 2: rising CCW
- 3: crossed output channel 1 rising / channel 2 falling CW (only $U_b = 5\text{ V}$)

Electrical connection

- 201: round cable 4-pol., 0.5 m shielded
- 202: round cable 4-pol., 1 m shielded**
- 206: round cable 4-pol., 3 m shielded**
- 210: round cable 4-pol., 5 m shielded
- 220: round cable 4-pol., 10 m shielded
- 501: connector M12 with round cable, L = 0.15 m, shielded version**

other cable lengths and assembled connectors on request

R S C - 2 8 3 2 - 6 3 6 - 2 1 1 - 2 0 2

Series

Measuring range

03: angle 0° ... 30° min.
 ...
06, 12, 18, 24, 36
 ...
 36: angle 0° ... 360° max.

Numbers of channels

- 6: one-channel**
- 7: redundant (two-channel) only $U_b = 5\text{ V}$

Mechanical version

- 2801: 6 mm shaft with marking, IP54*
- 2831: 6 mm shaft with marking, IP65*
- 2861: 6 mm shaft with marking, IP67*
- 2802: 6 mm shaft with marking, IP54
- 2832: 6 mm shaft with flattening, IP65**
- 2862: 6 mm shaft with flattening, IP67
- 2821: push-on coupling, IP54
- 2841: push-on coupling, IP65**
- 2871: push-on coupling, IP67

*) not recommended for new designs

Recommended accessories

Process-controlled indicators
 MAP300/400/4000 with
 display.

Available on request

- other measuring ranges
- other characteristics
- customized connectors
- other shaft designs