

Pressure reducing valve with DC motor operation, pilot operated

RE 29145/06.07
Replaces: 01 .00

1/12

Type DRG

Size 8 to 32
Component series 1X
Maximum operating pressure 315 bar
Maximum flow 300 l/min



tb0095

Table of contents

Content	Page
Features	1
Ordering code	2
Symbols	2
Function, section	3, 4
Technical data	5, 6
Electrical connection	7
Circuit example: Valve with limit switch	7
Characteristic curves	8
Unit dimensions	9 to 11
Mounting cavity for block installation	12

Features

- Actuation by a DC motor with reducing gear
- For subplate mounting:
Porting pattern to DIN 24340 Form D and ISO 5781
- For threaded connection
- For block installation
- 4 pressure ratings
- With actual value potentiometer or limit switch
- Check valve, optional
- Self-locking in the event of a power failure
(with variant with position switch, system pressure remains constant)

Further information:

Subplates to RE 45062

Information on available spare parts:
www.boschrexroth.com/spc

Ordering code



Pressure reducing valve with DC motor operation

Pilot operated valve = No code
 Pilot valve **without** main spool insert = C (do **not** enter size)
 Pilot valve **with** main spool insert = C (enter size **10** or **32**)

Size	Ordering code	
	Subplate mounting "No code"	Threaded connection "G"
8	-	= 8 (G3/8)
10	= 10	= 10 (G1/2)
16	-	= 15 (G3/4)
20	-	= 20 (G1)
25	= 20	= 25 (G1 1/4)
32	= 30	= 30 (G1 1/2)

For subplate mounting and block installation = No code
 For threaded connection = G

Further details in clear text

E1 = Limit switch
 P2 = Actual value potentiometer

Seal material
 No code = NBR seals
 V = FKM seals (other seals on request)

⚠ Attention!
 Observe compatibility of seals with hydraulic fluid used!

No code = With check valve
 M = Without check valve

Pilot oil flow
 Y = Pilot oil supply/drain see Symbols below

Pressure rating, max.
 50 = Set pressure up to 50 bar
 100 = Set pressure up to 100 bar
 200 = Set pressure up to 200 bar
 315 = Set pressure up to 315 bar

1X = Component series 10 to 19 (10 to 19: unchanged installation and connection dimensions)

Symbols

DRGC-1X/..Y

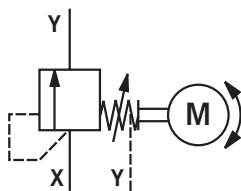

DRG..-1X/..Y..M
 DRG..G-1X/..Y..
 DRGC 10-1X/..Y.. and
 DRGC 30-1X/..Y..

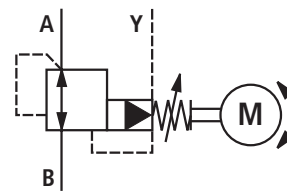

DRG..-1X/..Y

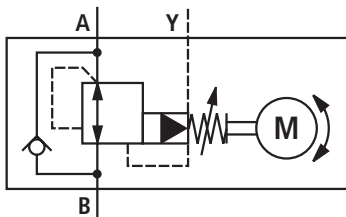

Function, section

Pressure control valves of type DRG are pilot operated pressure reducing valves.

They are used to reduce a system pressure.

Pressure reducing valves of this series basically consist of a pilot valve with electric motor with electric motor as pressure adjustment element, a main valve with main spool insert and an optional check valve.

The reduced pressure in A is adjusted by means of DC motor (16) with reducing gear (17). The output shaft of reducing gear (17) rotates cam (15), which changes the tension of spring (5) via spring plate (9) and thus causes a change in pressure.

The reduced pressure is present in port A, the inlet pressure in port B. The main fluid flow flows from B to A.

Actual value potentiometer (18) feeds back the position of cam (15).

Optionally, electrical limit switches can be installed instead of actual value potentiometer (18) for limiting the min. and max. pressure.

For the variant with limit switch, the min. adjustment time for the pressure range from p_{\min} to p_{\max} is 18 seconds.

The adjustment time of 18 seconds allows gradual reaching of the required pressure in the inching mode.

For the variant with actual value potentiometer the min. adjustment time for the pressure range from p_{\min} to p_{\max} is 1.3 seconds.

In conjunction with the associated amplifier type VT-VRM1-1 a program control can be realised.

With the help of 2 additional pressure switches, the min. and max. pressures can be limited.

With the variant with limit switch, the pressure setting on the valve is maintained in the event of a power failure (cable break, fuse failure, short-circuit, etc.).

Type DRG Sizes 8 and 10

The reduced pressure in A is applied simultaneously to the spring-loaded side of main spool (1) via orifice (2.1), pilot line (4), orifice (2.2) and orifice (3).

The pressure on the spring-loaded side of main spool (1) is by the pressure differential of compression spring (10.2) lower than the pressure in A. In the opening direction, compression spring (10.2) acts on main spool (1). According to the

opening cross-section of orifices (2.1; 2.2) and the pressure differential of compression spring (10.2), pilot oil flows through orifice (2.1), pilot line (4), orifice (2.2), poppet (6) into spring chamber (7) and further to the tank via Y (12.2) on the variant with subplate mounting or via (12.1) with the variant with threaded connection.

When the pressure in A rises above the value set on pilot valve (11), main spool (1) reduces the flow cross-section from B to A until the pressure set on pilot valve (11) is reached again in port A. Conversely, main spool (1) increases the flow cross-section from B to A, when the pressure in A is lower than the value set on pilot valve (11).

With a static oil column between A and the actuator, only the pilot oil flows via the main spool from B to A.

If, in this position, a lower pressure is set on pilot valve (11), main spool (1) interrupts the pilot oil supply from B to A until the oil volume isolated between A and the actuator has expanded to the lower pressure on pilot valve (11) via orifice (2.1), pilot line (4), orifice (2.2), poppet (6) and port Y.

A check valve (14) can optionally be installed to allow a free return flow from A to B.

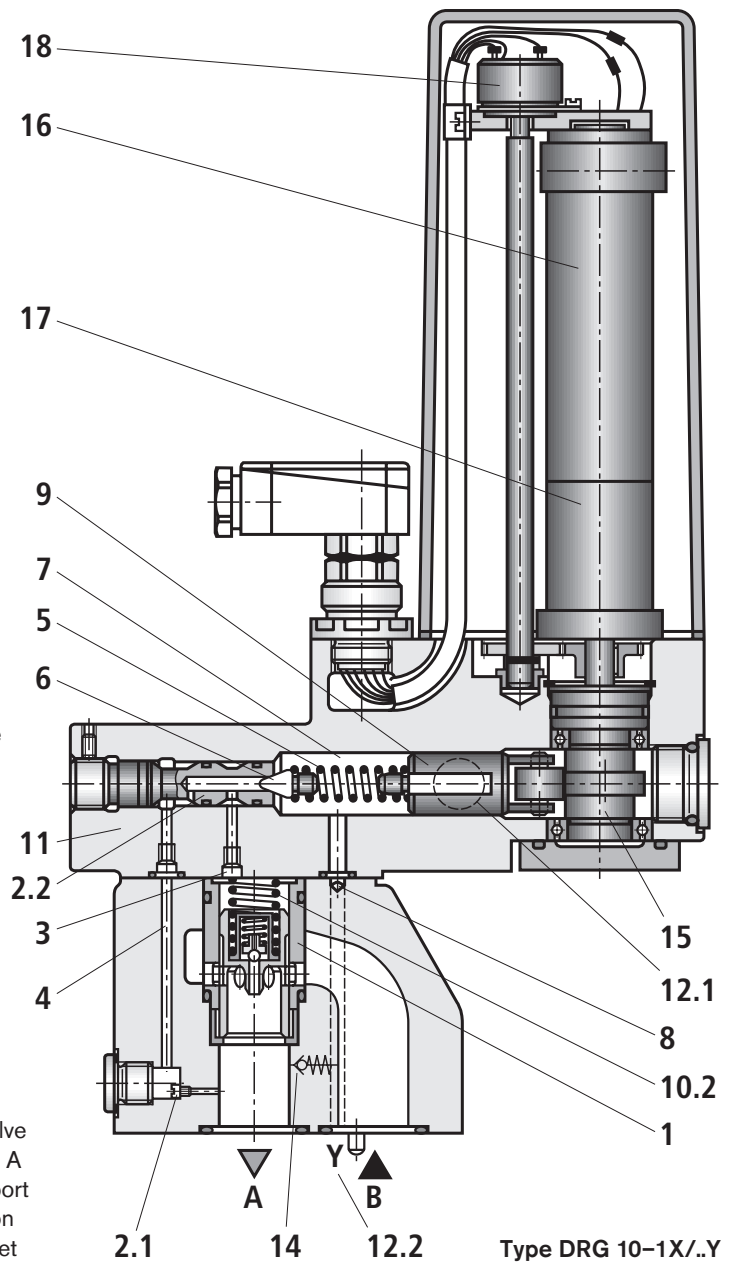

Type DRG 10-1X/.Y

Function, section

Type DRG sizes 16 to 32

Unlike with DRG 8 and DRG 10, with these valves, the pilot oil is taken from inlet pressure channel B. The flow regulator (13) holds the pilot oil flow constant.

If, with a static oil column between A and the actuator, a lower pressure is set on pilot valve (11), the oil column is unloaded via check valve (10.1), pilot line (4), poppet (6) and port Y.

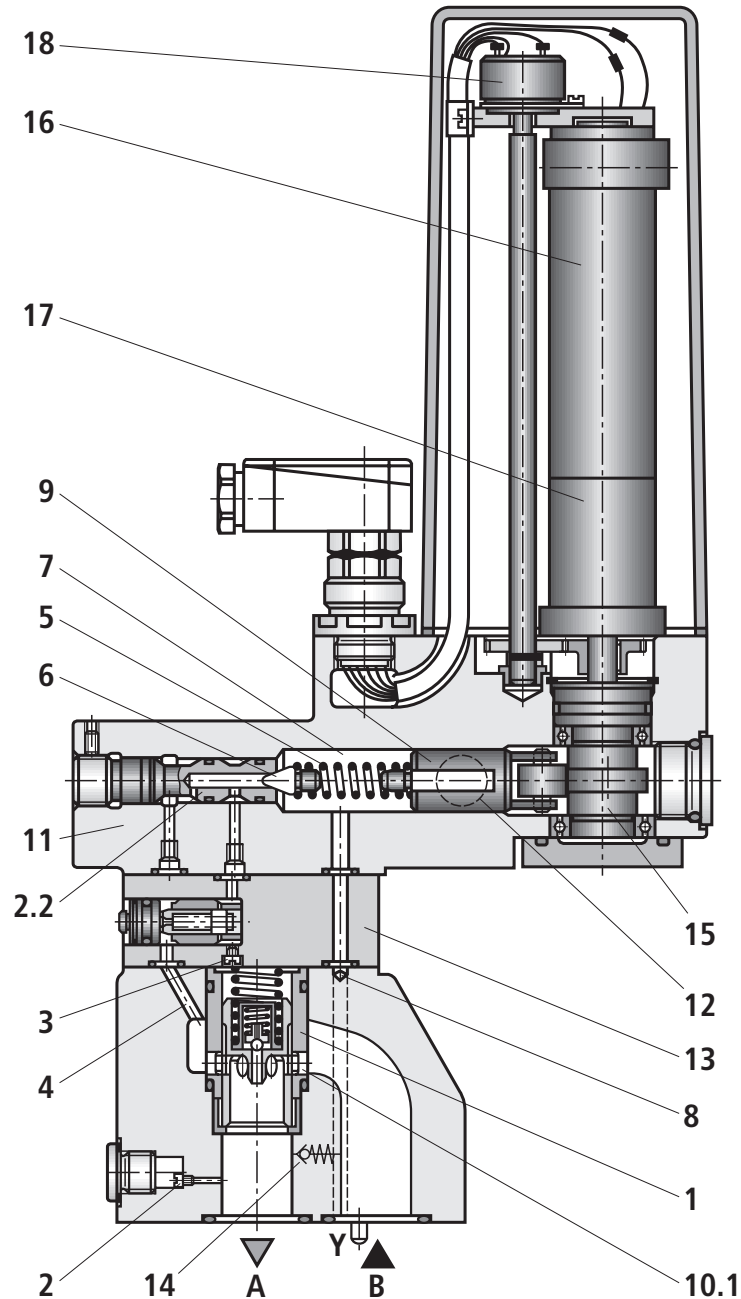

Type DRG 20-1X/..Y

Technical data (for applications outside these parameters, please consult us!)**General**

Size	Size	8	10	16	20	25	32		
Weight	– Subplate mounting	DRG...	kg	–	7.8	–	–	10.0	12.8
	– Threaded connection	DRG..G	kg	8.4	8.4	9.5	9.5	10.4	10.4
	– Block installation	DRGC 10..	kg	5.5	–	–	–	–	6.1
		DRGC 30..	kg	5.5	–	–	–	–	6.1
– Pilot valve without main spool insert	DRGC	kg	5.2	–	–	–	–	5.8	
Installation position				Optional					
Ambient temperature range			°C	–20 to +50					

Hydraulic

Inlet pressure	– Port B	bar	up to 315					
Pressure rating		bar	50	100	200	315	400	
Outlet pressure, can be regulated	– Port A	bar	up to 50	up to 100	up to 200	up to 315	up to 400	
Minimum set pressure		bar	Depending on q_v (see Characteristic curves on page 8)					
Backpressure	– Port Y	bar	up to 10					
Size	Size		8	10	16	20	25	32
Maximum flow	– Subplate mounting	l/min	–	80	–	–	200	300
	– Threaded connection	l/min	80	80	200	200	200	300
Pilot oil flow		l/min	0.5			1.3		
Hydraulic fluid			Mineral oil (HL, HLP) to DIN 51524 ¹⁾ ; fast bio-degradable hydraulic fluids to VDMT 24568 (see also RE 90221); HETG (rape seed oil) ¹⁾ ; HEPG (polyglycols) ²⁾ ; HEES (synthetic esters) ²⁾ ; other hydraulic fluids on request					
Hydraulic fluid temperature range		°C	–20 to +70					
Viscosity range		mm ² /s	2.8 to 380					
Permissible max. degree of contamination of the hydraulic fluid - cleanliness class to ISO 4406 (c)			Class 20/18/15 ³⁾					

Electrical, drive motor

Type of voltage			DC voltage					
Supply voltage		V–	24					
Rated power	– With limit switch	W	18					
	– With actual value potentiometer	W	24					
Electrical connection			Mating connector DIN 43651, 6-pin + PE					
Type of protection to EN 60529			IP 65 with mating connector mounted and locked					

¹⁾ Suitable for NBR **and** FKM seals

²⁾ Suitable **only** for FKM seals

³⁾ The cleanliness classes specified for components must be adhered to in hydraulic systems.

Effective filtration prevents malfunction and, at the same time, prolongs the service life of components.
For the selection of filters, see data sheets RE 50070, RE 50076, RE 50081, RE 50086 and RE 50088.

Technical data (for applications outside these parameters, please consult us!)**Adjustment with limit switch in inching mode: Ordering code "E1"**

Adjustment time, p_{\min} to p_{\max}	s	18					
Position switch variant:	– Micro-switch	20 V; 2 A DC					
	– Electric load	250 V; 5 A AC					
Pressure lag:	– Pressure rating	bar	50	100	200	315	400
	– Without short-circuit bridge	bar	1	2.5	5	7.5	10
	– With short-circuit bridge	bar	0.5	1	1.5	2	2.5

Adjustment with actual value potentiometer for cam position feedback function: Ordering code "P2"

Adjustment time, p_{\min} to p_{\max}	s	1.3					
Potentiometer	– Resistance	k Ω	5				
	– Power	W	1.75				

Adjustment hysteresis: Start-up pressure – deviation > 10 bar from nominal pressure

– Pressure rating	bar	50	100	200	315	400
– Hysteresis	bar	< 0.5	< 1	< 2.5	< 4	< 5

Adjustment hysteresis: Start-up pressure – deviation > 20 bar from nominal pressure

– Pressure rating	bar	50	100	200	315	400
– Hysteresis	bar	< 0.3	< 0.5	< 1	< 1.5	< 2
Repeatability	bar	< 0.5	< 1	< 1.3	< 1.7	< 2

Amplifier

Electrical amplifier	VT-VRM1-1, component series 1X – see RE 30405-D
----------------------	---

Electrical connection

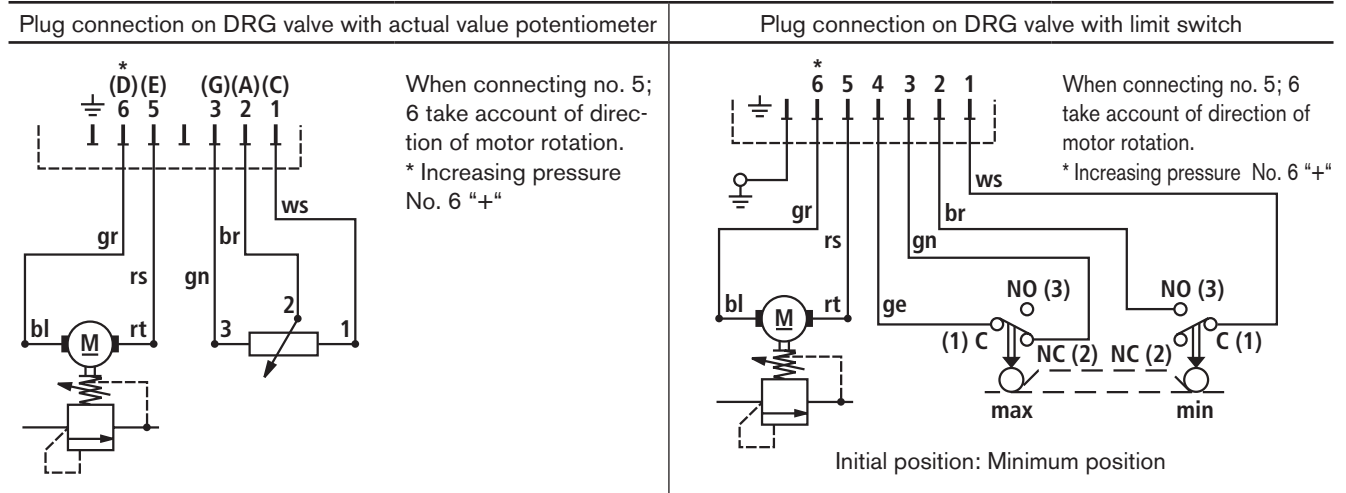

Circuit example: DRG valve with limit switch

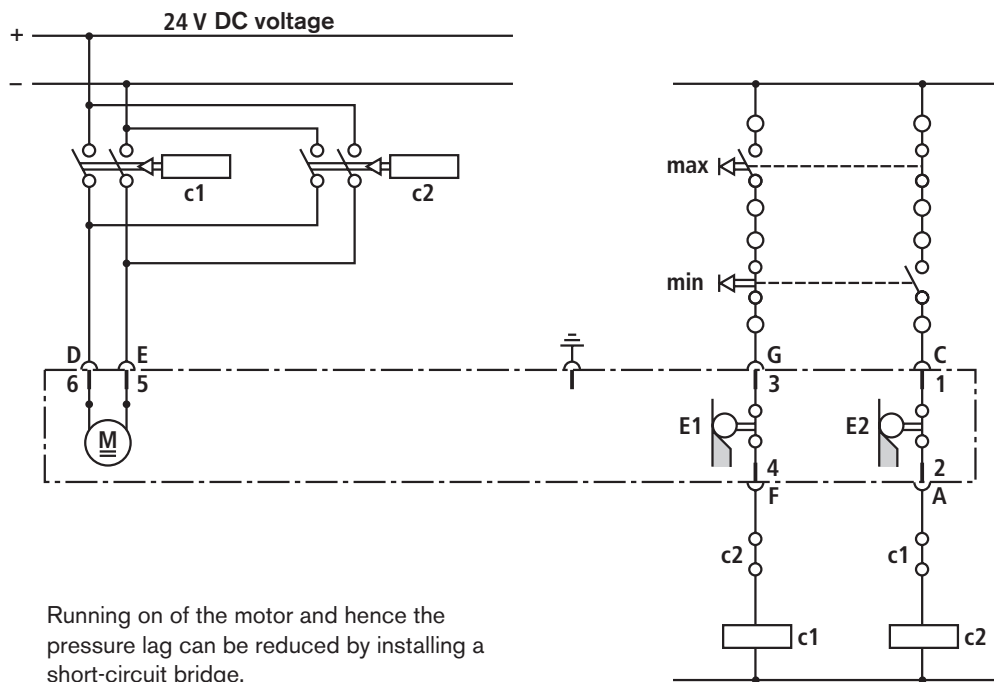

Characteristic curves (measured at $v = 41 \text{ mm}^2/\text{s}$ and $\vartheta_{\text{oil}} = 50 \text{ }^\circ\text{C}$)

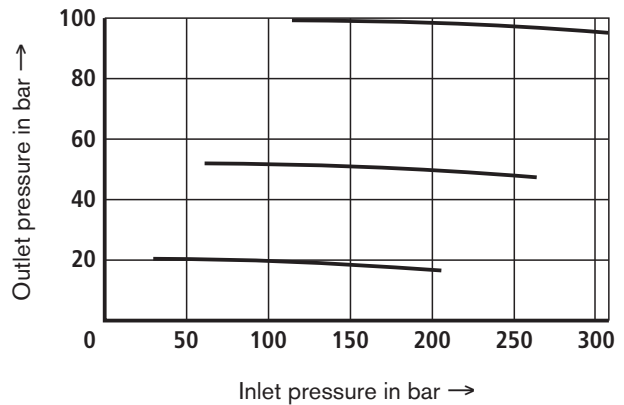
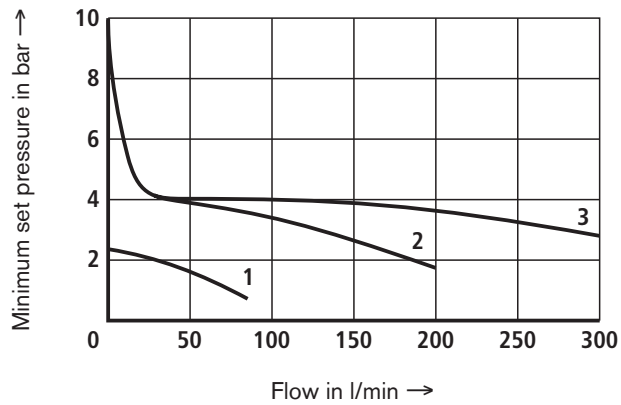
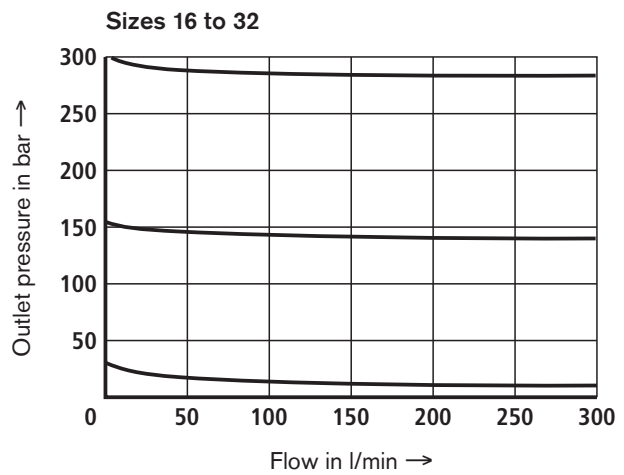
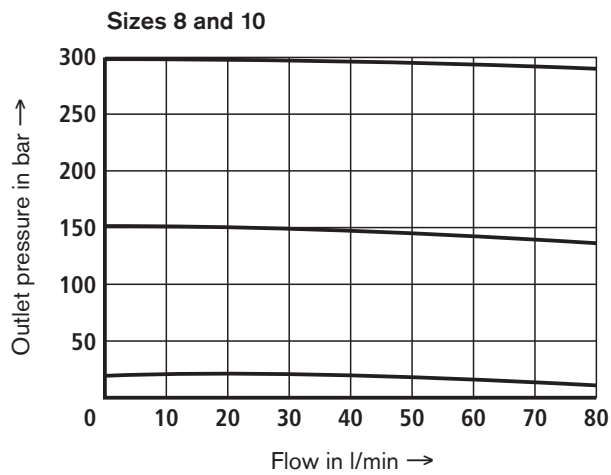

- 1 = DRG 8 and 10
- 2 = DRG 16 to 25
- 3 = DRG 30

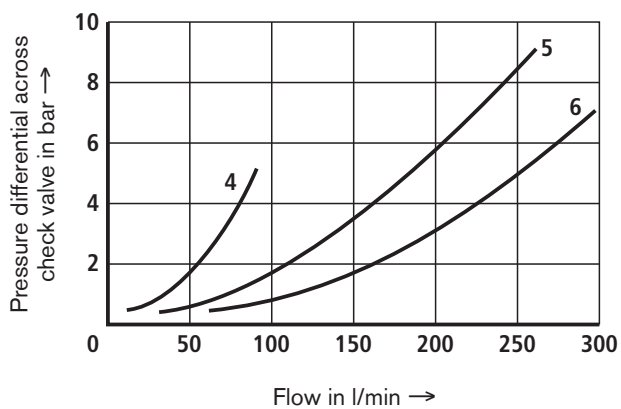

- 4 = DRG 10
- 5 = DRG 20
- 6 = DRG 30

Unit dimensions: Subplate mounting (dimensions in mm)

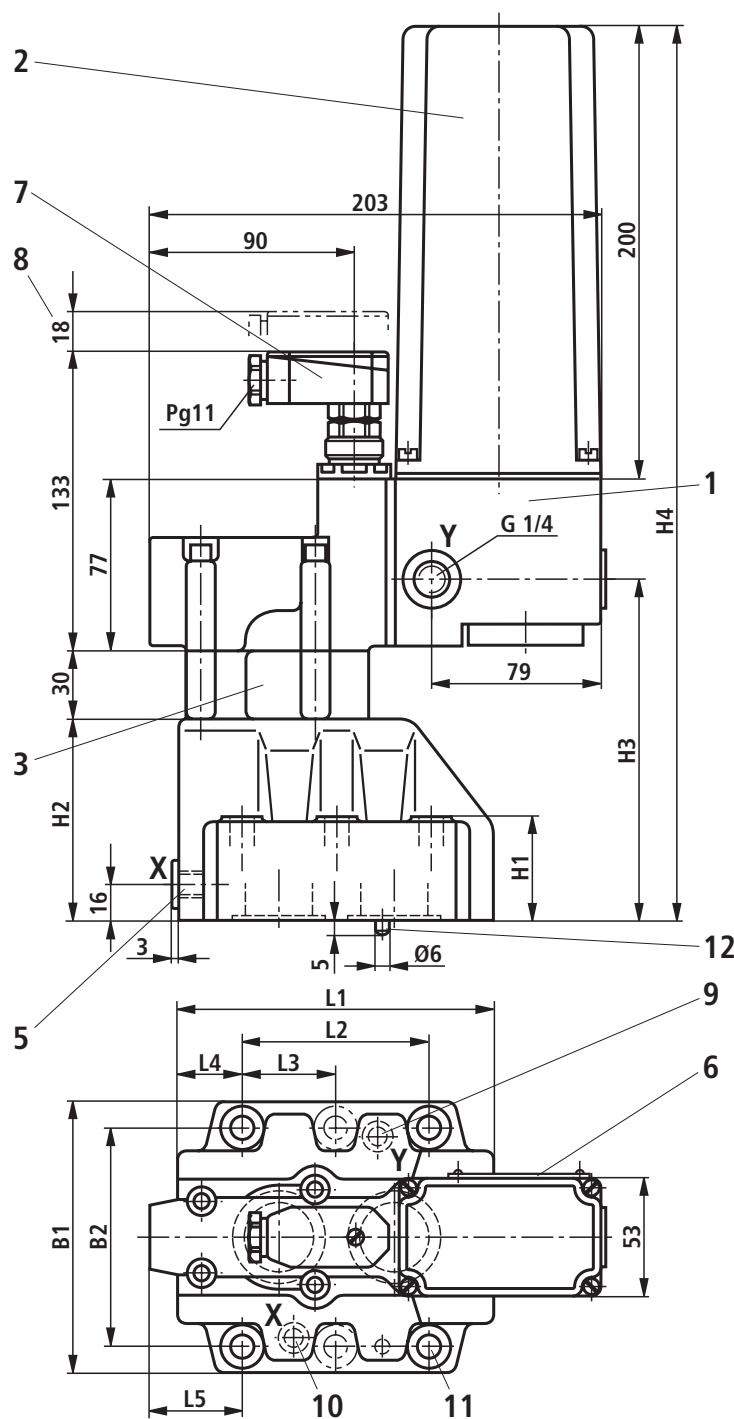

0,01/100mm
 Rzmax 4
 Required surface quality of valve mounting face

- 1 Pilot valve
- 2 DC motor
- 3 Constant flow regulator (only with sizes 25 and 32)
- 5 Port "X" for remote control on size 10
Port M for pressure gauge on sizes 25 and 32
- 6 Nameplate
- 7 Mating connector (included in scope of supply)
- 8 Space required to remove mating connector
- 9 Port "Y"
- 10 Port "X" without function (blind hole)
- 11 4 valve mounting bores for sizes 10 and 25
6 valve mounting bores for size 32
- 12 Locating pin

Subplates to data sheet RE 45062 (separate order)

- Size 10 G 460/01 (G3/8)
 G 461/01 (G1/2)
- Size 25 G 412/01 (G3/4)
 G 413/01 (G1)
- Size 32 G 414/01 (G1 1/4)
 G 415/01 (G1 1/2)

Valve fixing screws (separate order)

For strength reasons, only the following valve fixing screws may be used:

- Size 10
4 hexagon socket head cap screws ISO4762 - M10x50 - 10.9-fIZn-240h-L to VDA 235-101
 Friction coefficient $\mu_{total} = 0.09$ to 0.14 ,
 tightening torque $M_T = 59 \text{ Nm} \pm 10\%$,
 Material no. **R913000471**
- Size 25
4 hexagon socket head cap screws ISO4762 - M10x60 - 10.9-fIZn-240h-L to VDA 235-101
 Friction coefficient $\mu_{total} = 0.09$ to 0.14 ,
 tightening torque $M_T = 59 \text{ Nm} \pm 10\%$,
 Material no. **R913000116**
- Size 32
6 hexagon socket head cap screws ISO4762 - M10x70 - 10.9-fIZn-240h-L to VDA 235-101
 Friction coefficient $\mu_{total} = 0.09$ to 0.14 ,
 tightening torque $M_T = 59 \text{ Nm} \pm 10\%$,
 Material no. **R913000126**

The tightening torques given are guidelines when screws of the specified friction coefficients and a torque wrench (tolerance $\pm 10\%$) are used.

Tolerances according to:
 - General tolerances ISO 2768-mK

Size	B1	B2	H1	H2	H3	H4	L1	L2	L3	L4	L5	O-ring Port Y	O-ring Port A, B
10	85	66.7	28	72	102	349	90	42.9	-	35.5	44.5	9.25 x 1.78	17.12 x 2.62
25	102	79.4	38	82	142	389	112	60.3	-	33.5	46.5	9.25 x 1.78	28.17 x 3.53
32	120	96.8	46	90	150	397	140	84.2	42.1	28	41.5	9.25 x 1.78	34.52 x 3.53

Unit dimensions: Threaded connection (dimensions in mm)

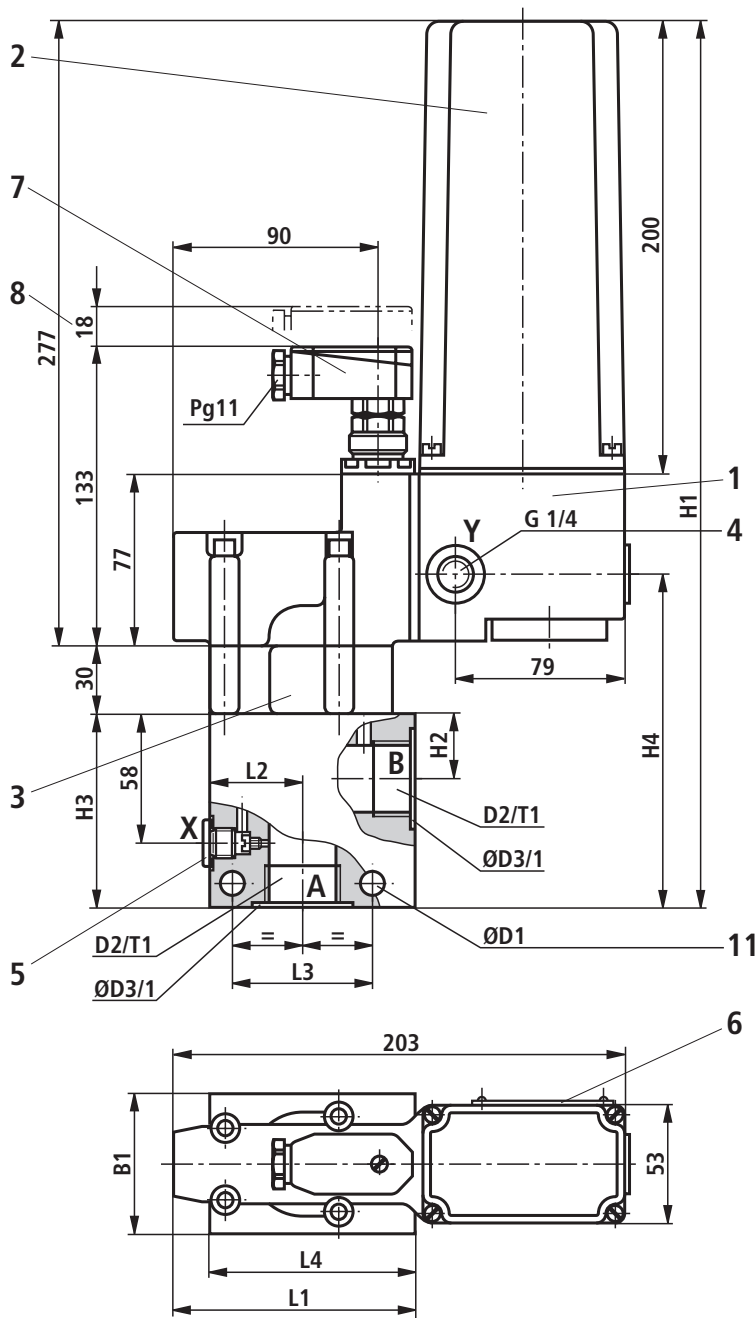

- 1 Pilot valve
- 2 DC motor
- 3 Constant flow regulator (only on sizes 16 to 32)
- 4 Port "Y" for external pilot oil drain
- 5 Port "X" for remote control on sizes 8 and 10
Port M for pressure gauge on sizes 16 to 32
- 6 Nameplate
- 7 Mating connector (included in scope of supply)
- 8 Space required to remove mating connector
- 11 Valve mounting bore

Note!

On this valve variant, no check valve is integrated in the valve to allow a free return flow from A to B.

Tolerances according to:

– General tolerances ISO 2768-mK

Size	B1	ØD1	D2	ØD3	H1	H2	H3	H4	L1	L2	L3	L4	T1	
8	63	9	G3/8	28	362	23	75	115	108	40	62	90	12	
10			G1/2	34									14	
16			G3/4	42	392			28					145	16
20			G1	47										18
25	70	11	G1 1/4	56	405	34	85	158	111	46	72	99	20	
32			G1 1/2	61									22	

Unit dimensions: Block installation (dimensions in mm)

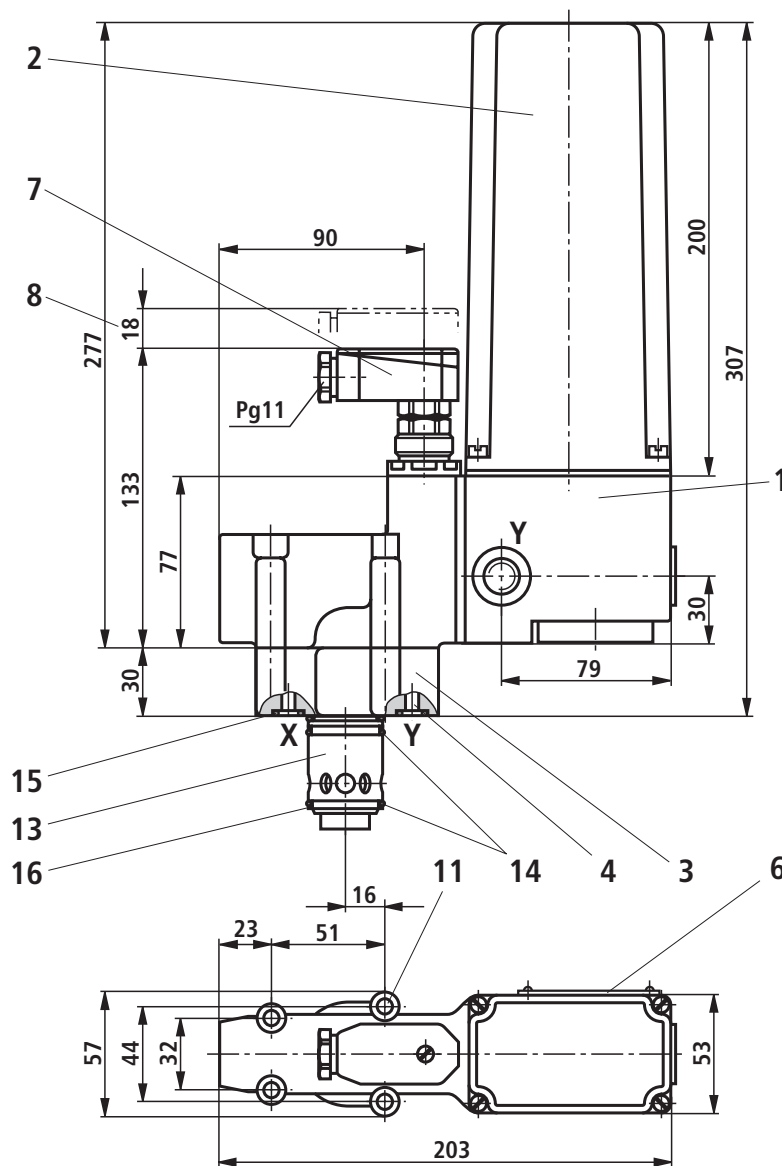

- 1 Pilot valve
- 2 DC motor
- 3 Constant flow regulator (only on size 32)
- 4 Port "Y" for pilot oil drain
- 6 Nameplate
- 7 Mating connector (included in scope of supply)
- 8 Space required to remove mating connector
- 11 Valve mounting bores
- 13 Main spool insert
- 14 O-ring 27.3 x 2.4
- 15 O-ring 9.25 x 1.78
- 16 Back-up ring 32/28.4 x 0.8

Valve fixing screws (separate order)

For strength reasons, only the following valve fixing screws may be used:

- Size 10

4 hexagon socket head cap screws ISO4762 - M8x50 - 10.9-fIZn-240h-L to VDA 235-101

Friction coefficient $\mu_{\text{total}} = 0.09$ to 0.14 ,
tightening torque $M_T = 31 \text{ Nm} \pm 10\%$,
Material no. **R913000543**

- Size 32

4 hexagon socket head cap screws ISO4762 - M8x80 - 10.9-fIZn-240h-L to VDA 235-101

Friction coefficient $\mu_{\text{total}} = 0.09$ to 0.14 ,
tightening torque $M_T = 31 \text{ Nm} \pm 10\%$,
Material no. **R913000276**

The tightening torques given are guidelines when screws of the specified friction coefficients and a torque wrench (tolerance $\pm 10\%$) are used.

Mounting cavity for block installation (dimensions in mm)

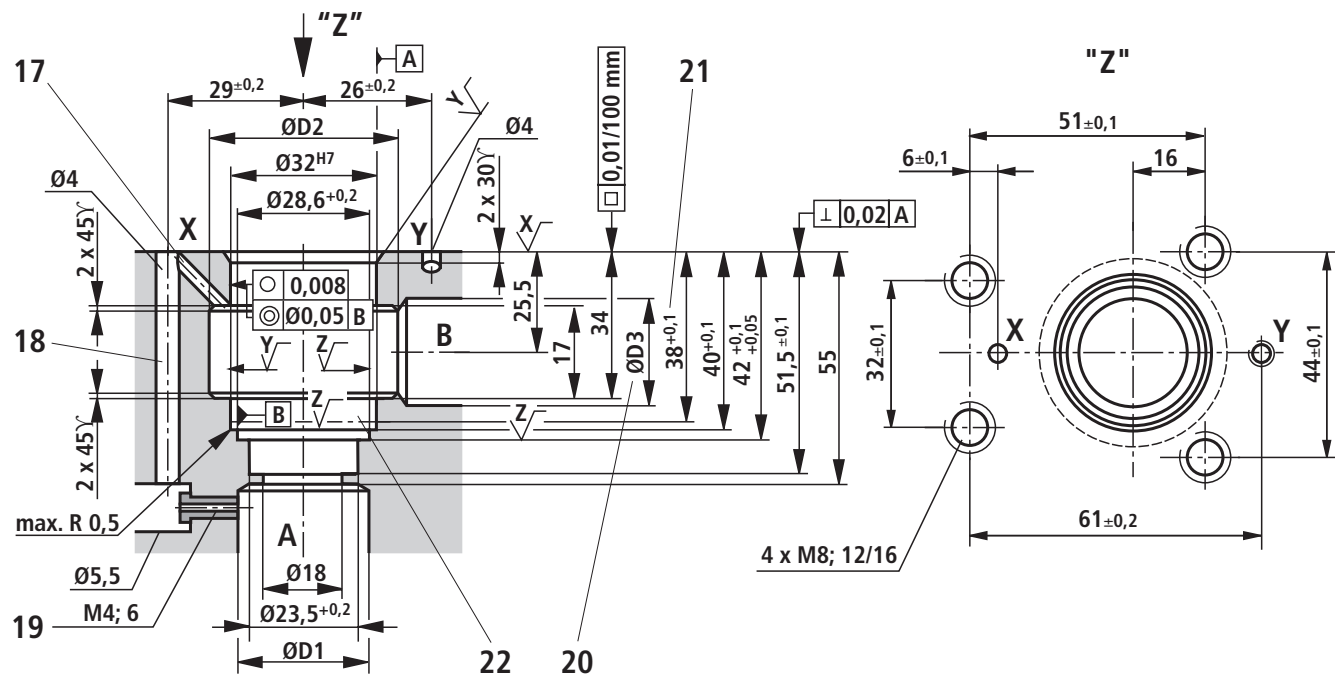

$$\sqrt{X} = \sqrt{Rz_{max} 4}$$

$$\sqrt{Y} = \sqrt{Rz_{max} 8}$$

$$\sqrt{Z} = \sqrt{Rz 16}$$

Size	ØD1	ØD2	Ø D3
10	10	40	10
32	32	45	32

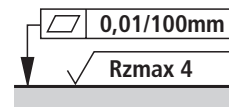

Required surface quality of valve mounting face

Tolerances according to:

- General tolerances ISO 2768-mK

- 17 Pilot oil tapping on size 32
- 18 Pilot oil tapping on size 10
- 19 Pilot oil tapping nozzle on size 10
- 20 Bore ØD3 can intersect ØD2 at any point. However, care must be taken that connection bore X and the fixing screws are not damaged.
- 21 Depth of fit
- 22 The back-up ring and the O-ring must be inserted in this bore before the main spool is installed