

ADAPTOR
TNC 50 Ω jack - jack

56K101-K00N5

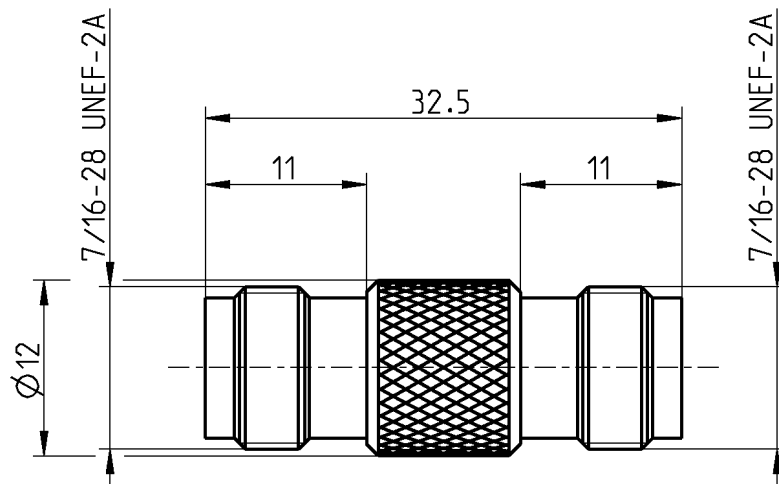

All dimensions are in mm; tolerances according to ISO 2768 m-H

Interface

According to IEC 60169-17, MIL-PRF-39012, DIN EN 122200

Documents

N/A

Material and plating

Connector parts

- Center contact
- Outer contact
- Body
- Dielectric

Material

- Spring bronze
- Brass
- Brass
- PTFE

Plating

- AuroDur®, gold plated
- Flash white bronze over silver(e.g. Optargen®)
- Flash white bronze over silver(e.g. Optargen®)

ADAPTOR
TNC 50 Ω jack - jack

56K101-K00N5

Electrical data

Impedance	50 Ω
Frequency	DC to 10 GHz
Return loss	≥ 30 dB, DC to 2.5 GHz ≥ 20 dB, 2.5 to 6 GHz
Insertion loss	≤ 0.05 dB, DC to 6 GHz
Insulation resistance	≥ 5 x10 ³ MΩ
Center contact resistance	≤ 1.5 mΩ
Outer contact resistance	≤ 1 mΩ
Test voltage	1500 V rms
Working voltage	500 V rms
Power handling (at 20 °C, sea level, VSWR 1.0)	≤ 80 W @ 2 GHz

Mechanical data

Mating cycles	min. 500
Center contact captivation: axial	≥ 15 N
Coupling test torque	max. 1.7 Nm
Recommended torque	0.46 Nm to 0.69 Nm

Environmental data

Temperature range	-45°C to +85°C
Thermal shock	MIL-STD-202, Meth. 107, Cond. B
Corrosion	MIL-STD-202, Meth. 101, Cond. B
Vibration	MIL-STD-202, Meth. 204, Cond. B
Shock	MIL-STD-202, Meth. 213, Cond. G
Moisture resistance	MIL-STD-202, Meth. 106
RoHS	compliant

Tooling

N/A

Suitable cables

N/A

Packing

Standard	1 pce in bag
Weight	13.5 g/pce

While the information has been carefully compiled to the best of our knowledge, nothing is intended as representation or warranty on our part and no statement herein shall be construed as recommendation to infringe existing patents. In the effort to improve our products, we reserve the right to make changes judged to be necessary.

Draft	Date	Approved	Date	Rev.	Engineering change number	Name	Date
Chr. Entsfellner	24/07/08	Gasteiger A.	19.09.13	c01	13-0008	J. Krautenbacher	08.10.13
Rosenberger Hochfrequenztechnik GmbH & Co. KG P.O.Box 1260 D-84526 Tittmoning Germany www.rosenberger.de					Tel.: +49 8684 18-0 Fax: +49 8684 18-499 email: info@rosenberger.de		Page 2 / 2