

# GN 269 | Crank handles

Stainless steel



## MATERIAL

Cast AISI CF-8 stainless steel, sandblasted matte finish.

## STANDARD EXECUTION

Handle l.280 (see page 560) in Duroplast with AISI 304 stainless steel revolving pin.

- **GN 269-B:** H9 reamed hole.
- **GN 269-V:** H11 square hole.

# GN 369 | Crank handles

Steel



## MATERIAL

Sandblasted and nickel-plated steel with arm welded to the hub.

## HUB CAP

Technopolymer, black colour.

## STANDARD EXECUTION

Hub, H9 hole with end grooving. Handle l.280 (see page 560) in Duroplast.

## SPECIAL EXECUTIONS ON REQUEST

Hub without end grooving.

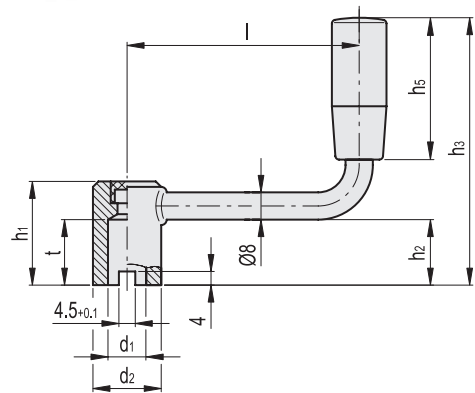
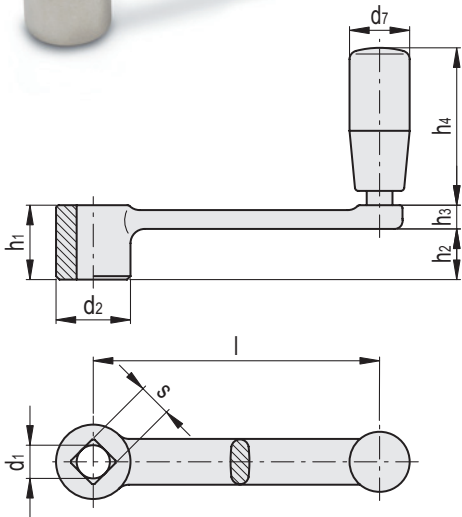

Code	Description	l	d1 H9	s H11	d2	h1	h2	h3	h5	△
GN.56851	GN 269-80-B10	80	10	-	22	22	15.4	6.6	45	120
GN.56852	GN 269-80-V10	80	-	10	22	22	15.4	6.6	45	123
GN.56856	GN 269-100-B12	100	12	-	26	26	17.7	8.3	55	200
GN.56857	GN 269-100-V12	100	-	12	26	26	17.7	8.3	55	187
GN.56861	GN 269-125-B14	125	14	-	28	28	18.8	9.2	71	300
GN.56862	GN 269-125-V14	125	-	14	28	28	18.8	9.2	71	320
GN.56866	GN 269-160-B17	160	17	-	32	32	22.6	9.4	71	380
GN.56867	GN 269-160-V17	160	-	17	32	32	22.6	9.4	71	370
GN.56871	GN 269-200-B19	200	19	-	38	38	28	9.4	71	384
GN.56872	GN 269-200-V19	200	-	19	38	38	28	9.4	71	374

Code	Description	l	d1 H9	d2	h1	h2	h3	h5	t±0.5	△
GN.22101	GN 369-63-B10-N	63	10	18	28	18	74	40	18	87
GN.22111	GN 369-80-B10-N	80	10	18	28	18	74	40	18	93
GN.22121	GN 369-100-B12-N	100	12	20	30	20	88	50	20	121
GN.22131	GN 369-125-B12-N	125	12	20	30	20	88	50	20	131