

## NC transport trolley

### Application:

For safe and professional storage of tool holders

### Execution:

- Very robust and stable construction

### Advantage:

- Safe storage and provision of tools
- Tool storage and transportation in one trolley

<b>Art. no.</b>	<b>50304 178</b>
<b>Brand</b>	LISTA
<b>Manufacturer Part Number</b>	15.419.010
<b>Depth</b>	514 mm
<b>Width</b>	1077 mm
<b>Height</b>	932 mm
<b>Gross Weight</b>	61.000 kg
<b>Product Group</b>	5AN

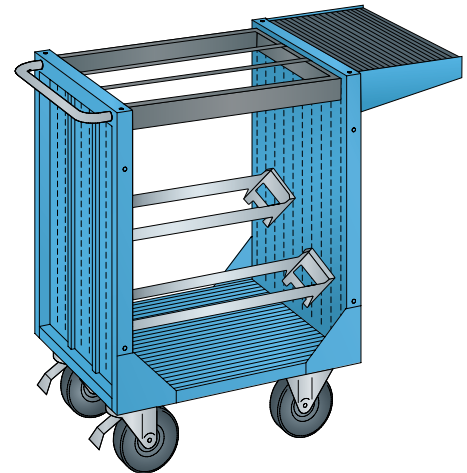

### EAN

7612269049954