

The supplier acknowledges that, with the acceptance of the drawing, he is in a position to manufacture the illustrated part in accordance with the drawing in reproducible form and series production. Through the selected manufacturing processes no impairments will arise in the material and structure which could subsequently lead to an impairment of the component. Verbal agreements over and above that are not valid. Deviations from this rule must be written and must be signed by the purchaser.

This drawing may not be copied, reproduced or made available to third parties in any whatsoever without the prior written approval.

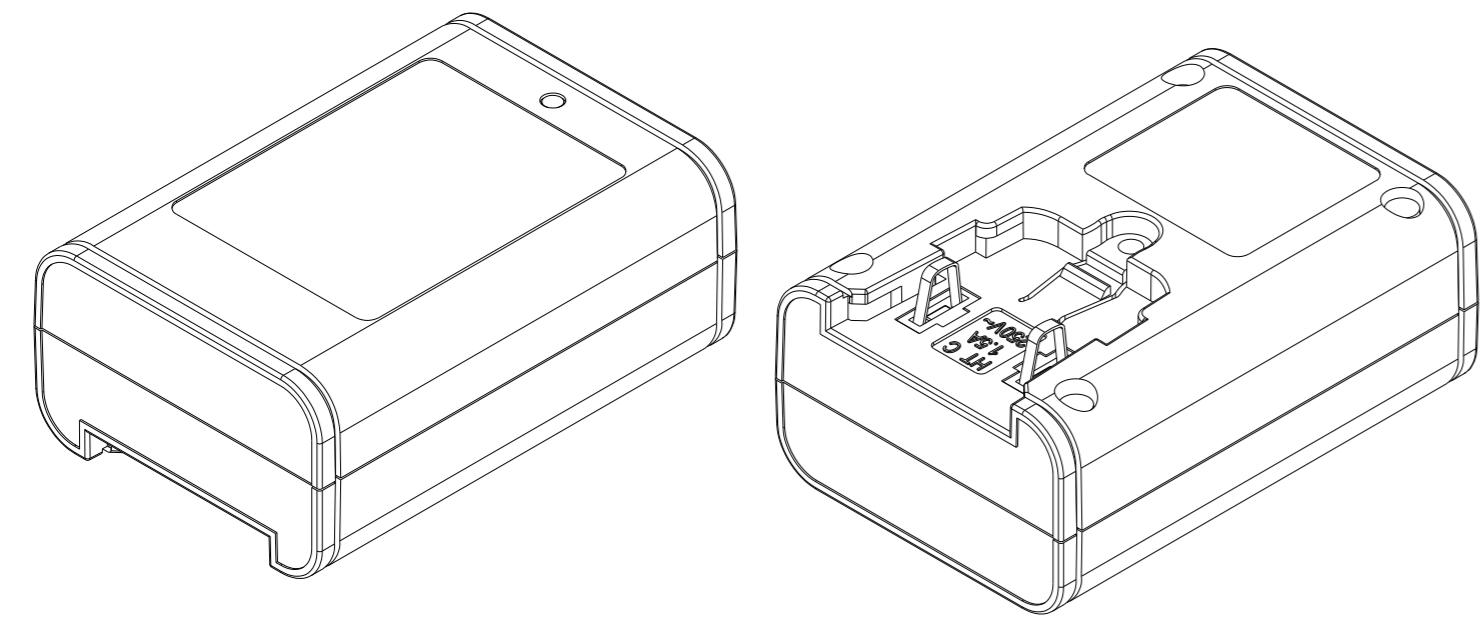

Technische Daten/ technical data	: Steckerladegerät/ plug-in charger
Chemie/ chemistry	: Li-Ion
Zellenzahl/ no. of cells	: 2 Zellen/ cells
ladbare Kapazität/ loadable capacity	: max. 17.4Ah
Eingangsspannung/ input voltage	: 100-240VAC ±10% / 50-60Hz
Eingangs-Schutz/ primary electrical protection	: Sicherung T3.15A fuse
Leistungsaufnahme im Leerlauf/ stand-by power consumption	: ≤ 0.5W
Nenn-Leistungsaufnahme/ nominal power consumption	: ≤12W
Ableitstrom/ Leakage current	: < 250uA
Ausgangsspannung im Leerlauf/ no load output voltage	: ca./ approx. 0-10VDC (pulsing)
Vorladespannung/ pre-charge voltage	: 6V
Vorladestrom/ pre-charge current	: 0.04A (U<5.0V) / 0.12A (U>=5.0V)
Nennausgangsspannung/ nominal output voltage	: 7.4V
Nennladestrom/ nominal charge current	: 1.45A
Ladeschlußspannung/ charge end voltage	: 8.42V
Ladeschlußstrom/ charge end current	: 0.2A
Lade Wiedereinschaltspannung/ charge restart voltage	: 8V
Rückstrom ohne Netzspannung/ reverse current without AC	: < 100uA bei/ at 16.8VDC
Ausgangs-Schutz/ secondary electrical protection	: Kurzschluss/ short circuit
Akku-Vollerkennung/ battery full detection	: CCCV
Sicherheitstimer/ safety timer	: 1hr (pre-charge) / 12hr (charge)
Spannungsfestigkeit/ electric strength	: 4 kV Eingang/Ausgang primary/secondary
Schutzklasse/ protection class	: II
Betriebstemperatur/ operating temperature	: 0°C...+40°C
Lagertemperatur/ storage temperature	: -25°C...+60°C
Luftfeuchtigkeit im Betrieb/ humidity: operation	: 10%-90% (non-condensing)
Transport & Lagerung/ transport & storage	: 10%-95% (non-condensing)
Einsatzhöhe/ altitude	: max. 2000m
Transport & Lagerung/ transport & storage	: max. 12000m
Luftdruck im Betrieb/ Air pressure: operation	: 795-1060hPa
Transport & Lagerung/ transport & storage	: 500-1060hPa

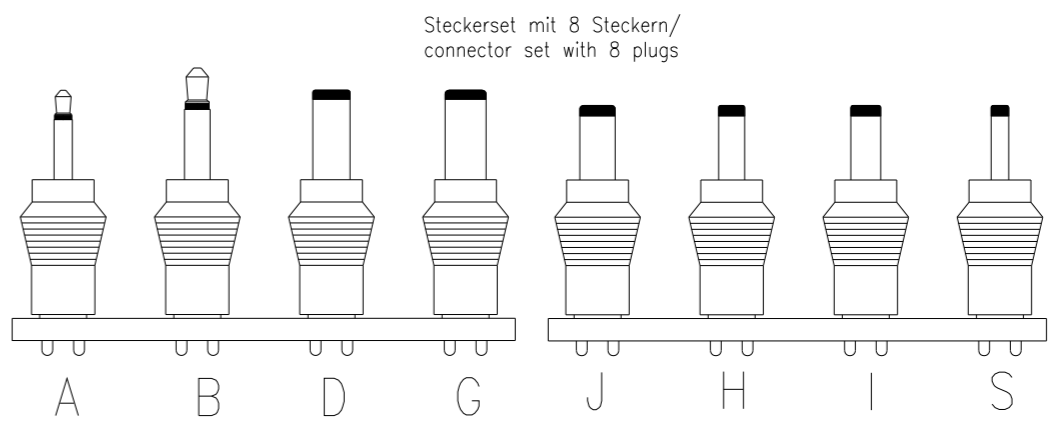
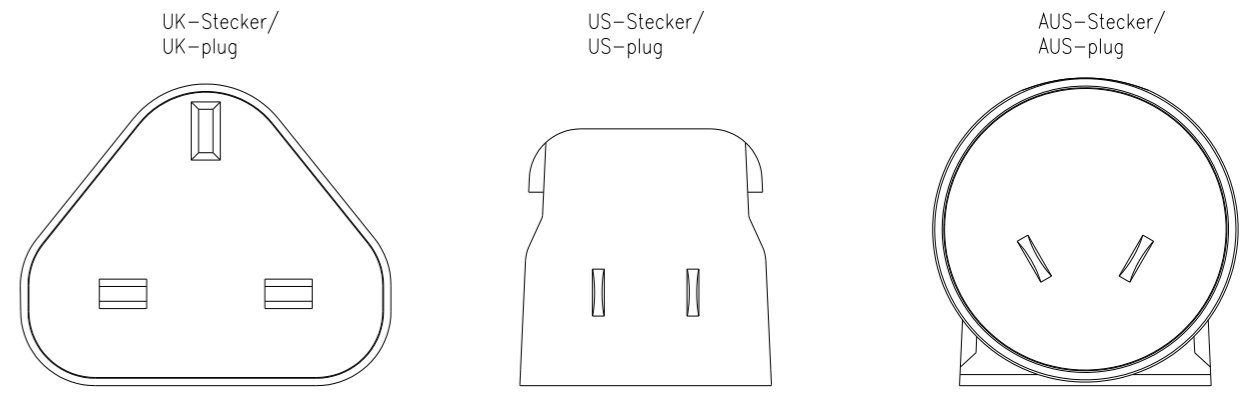
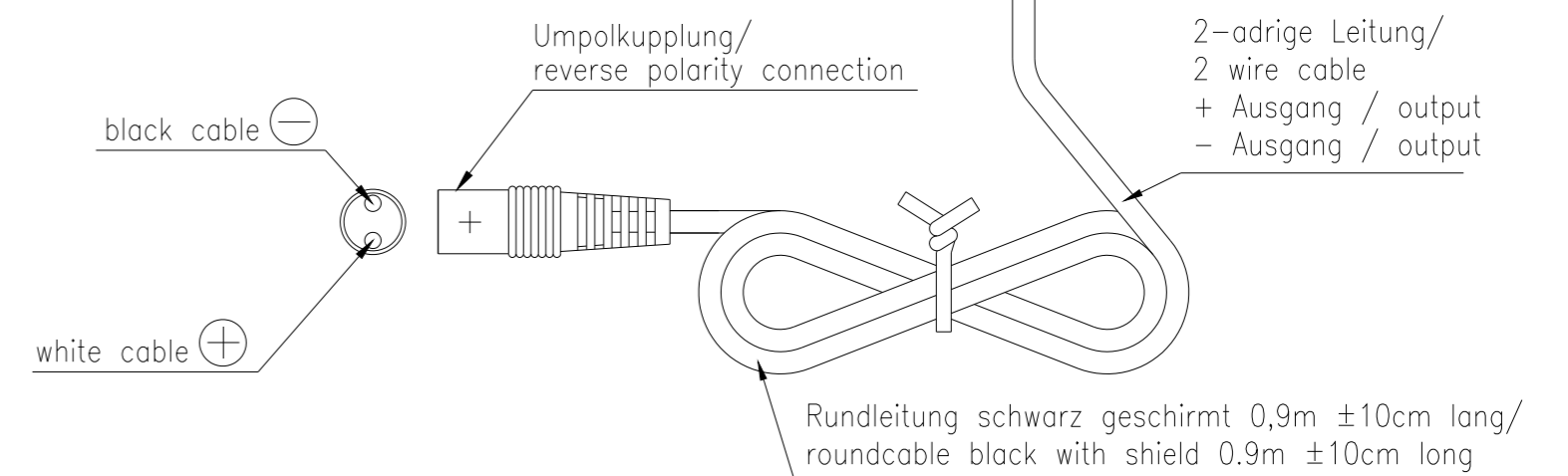
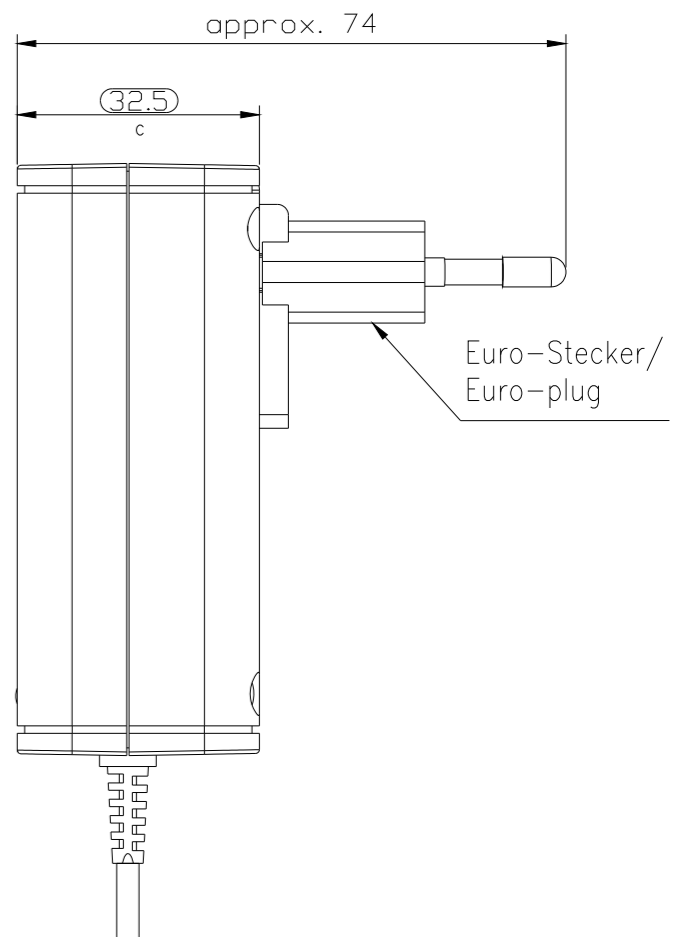
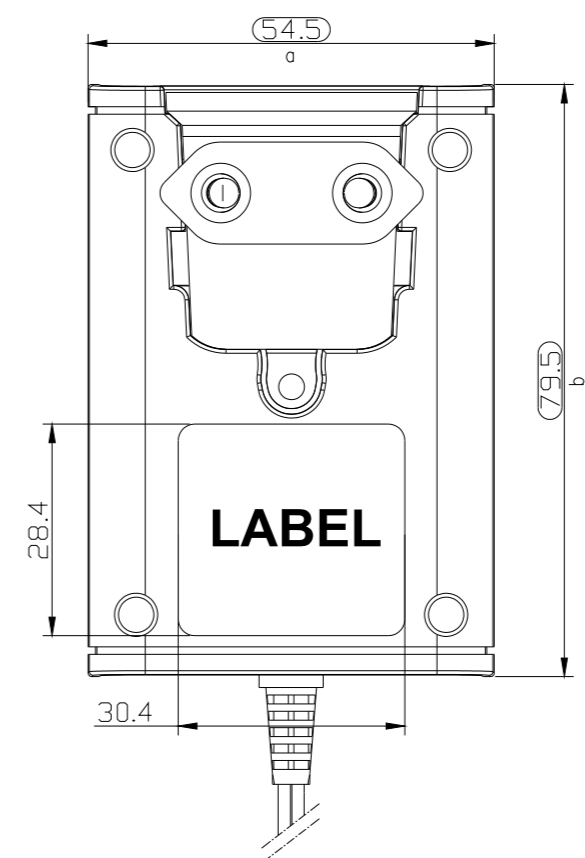
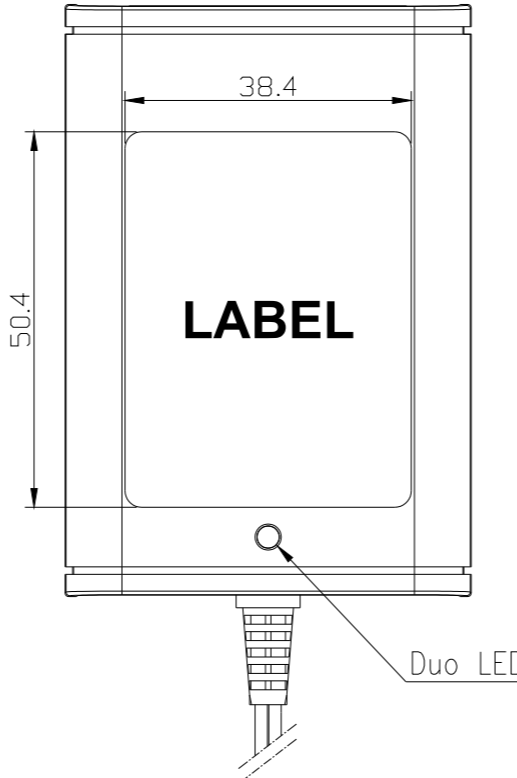

plug	plug description	plug size	part number
A	jackplug	2.5x12mm	10950038
B	jackplug	3.5x15mm	10950037
D	hollowplug	2.1x5x12mm	10950107
G	hollowplug	2.5x5.5x12mm	10950377
J	hollowplug	1.75x4.75x10mm	10950105
H	hollowplug	1.35x3.5x10mm	10950036
I	hollowplug	1.7x4x10mm	10950399/01
S	hollowplug	2.35x0.75x10mm	10950078

Nettogewicht/ net weight	: 150g
Gehäuse/ case	: Steckergehäuse, schwarz, Typ/ APS1500T plug-in housing, black, type
Gehäusematerial/ case material	: PC plastic UL94V-0
Leiterplattenmaterial/ pcb material	: FR4
Schutzart/ case protection	: IP 20
Typenschild Vorderseite/ ratingplate front	: Weißes Label mit schwarzer Bedruckung/ white label with black printing
Typenschild Rückseite/ ratingplate back	: ---
Anleitungen/ instructions	: mehrsprachig/ multilingual
Approbationen/ approvals	: CE, UKCA, CB report
Normen/ standards	: CB IEC 60335-2-29, IEC 60335-1, CE EMC EN 55015-1, EN 61000-3-2, EN 61000-3-3, EN 55014-2
Duo LED indicator	
charging inactive (power on)	: flash green 0.2Hz
charging (CC/CV)	: flash green 1Hz
charging finished	: lights green
error (battery/charger/muting)	: flash red
(under-voltage, over-voltage, short circuit)	

Allowable deviation general tolerances		Surface:	Material:	Weight
DIN ISO 2768-m		Date	Scale (DIN A2): 1:1	Projection method 1
Date		Name	Product name:	
Drawn by 24.11.2022		DS		IPC-12-Uni-charger-LI-ION-2-cell
Changed by				
Part number 2000-3012		Project: IS-711052		Sheet 1/1
Application range for inquiry		XXX/XX		



V0	---	XX.XX.XXXX	XX
Version	Change	Date	Name