



Product Change Notification

Date Issued :	March 23, 2023	PCN Number :	513474
Reason for Change :	Capacity change or tool replacement		
Description of Change :	Due to OEM increase in product, we are experiencing extremely high demand beyond our capacity to respond within lead time. so this letter is to inform the additional component tooling to increase output.		
Reason for Short Notice :	Capacity Increase		
Assessment of Change :	First Article Inspection		
Planned Implementation Date :	July 14, 2023		
Sample Availability Date:	May 31, 2023		
Internal Molex Qualification Date :	July 01, 2023		
Last date to request Samples by Customer :	June 23, 2023		
Traceability Code Markings / Date :	Product made after planned implementation date can contain the change		

Before Picture

Overview

- Due to OEM increase in product, we are experiencing extremely high demand beyond our capacity to respond within lead time. so this letter is to inform the additional component tooling to increase output.
- Product Impact
 - “no impact to fit, form or function”
- Part Number Impact
 - Please refer attached impacted part list.
- Qualification Reports and samples available from 1st of July.
- PPAP will be available on 14/07/2023.
 - If PPAP requested, disposition response required within 5 days of submit date or it will be considered approved.
 - If no PPAP requested by 16/07/2023, the PPAP will be considered approved.

After Picture

- Affected products as shown below,

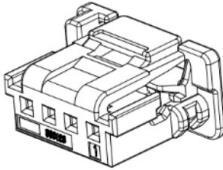
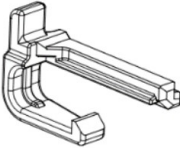
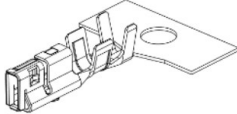
Receptacle 560123 560235	ISL 560125 560237	Terminal 560124 560236
		

RELEASED

You may address inquires regarding this PCN by clicking on the below link
mailto:pcn_coordinator@molex.com?subject=PCN_Notification:513474
 or contact your Local Sales Engineer.

Note: While responding, please retain " PCN Notification : **PCN Notification: 513474** " in the e-mail Subject line for faster response.

[Molex, LLC](#)
 2222 Wellington Court
 Lisle, IL 60532
 TEL (800) 786-6539
www.molex.com