

Display Elektronik GmbH

DATA SHEET

LCD MODULE

DEM 16227 SBH-PW-N

Product Specification

Version : 2

28.03.2013

DOCUMENT REVISION HISTORY

Version	DATE	DESCRIPTION	CHANGED BY
00	25.02.2013	First issue	MH
01	06.03.2013	Delete the explanation of the mould's deadline	MH
02	28.03.2013	Add the drawing of packing and appendix (Page 23,24)	MH

CONTENTS

1. Functions & Features	1
2. Mechanical Specifications	1
3. Block Diagram	1
4. Dimensional Outline	2
5. Pin Description	3
6. Maximum Absolute Limit	3
7. Backlight Characteristics	3
8. Electrical Characteristics	4
9. Electro-Optical Characteristics	6
10. Control and Display Command	7
11. Font Characteristic	8
12. Precaution For Using LCD/LCM	9
13. Appendix (Jumper Configuration)	11

1. FUNCTIONS & FEATURES

Display Format	: 16x2 characters
LCD Mode	: STN-BLUE, Negative, Transmissive
Viewing Direction	: 6 O'clock
Driving Scheme	: 1/16 Duty cycle, 1/5 Bias
Power Supply Voltage (V _{DD})	: 5.0 Volt (typ.)
1.6. LCD driving voltage	: 3.9 Volt (typ.)
Operation Temperature	: -20 to +70°C
Storage Temperature	: -30 to +80°C
Backlight Color	: LED, Edge, White

2. MECHANICAL SPECIFICATIONS

Module Size	: 85.00 x 30.00 x 13.60 mm
Viewing Area	: 65.00 x 17.20 mm
Character Pitch	: 3.65 x 5.05 mm
Character Size	: 2.95 x 4.35 mm
Dot Pitch	: 0.60 x 0.55 mm
Dot Size	: 0.55 x 0.50 mm

3. BLOCK DIAGRAM

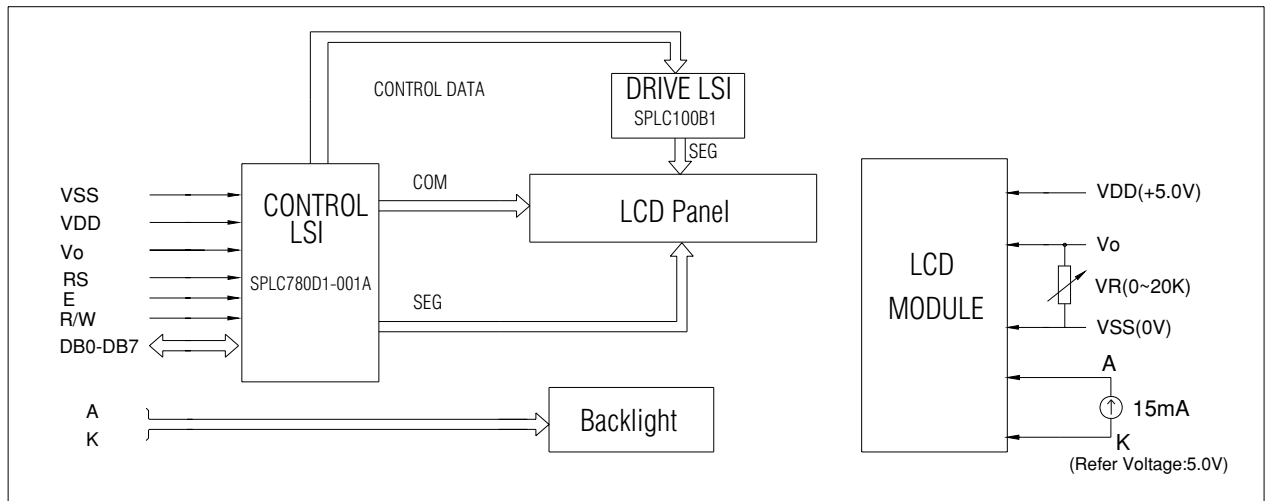
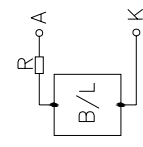
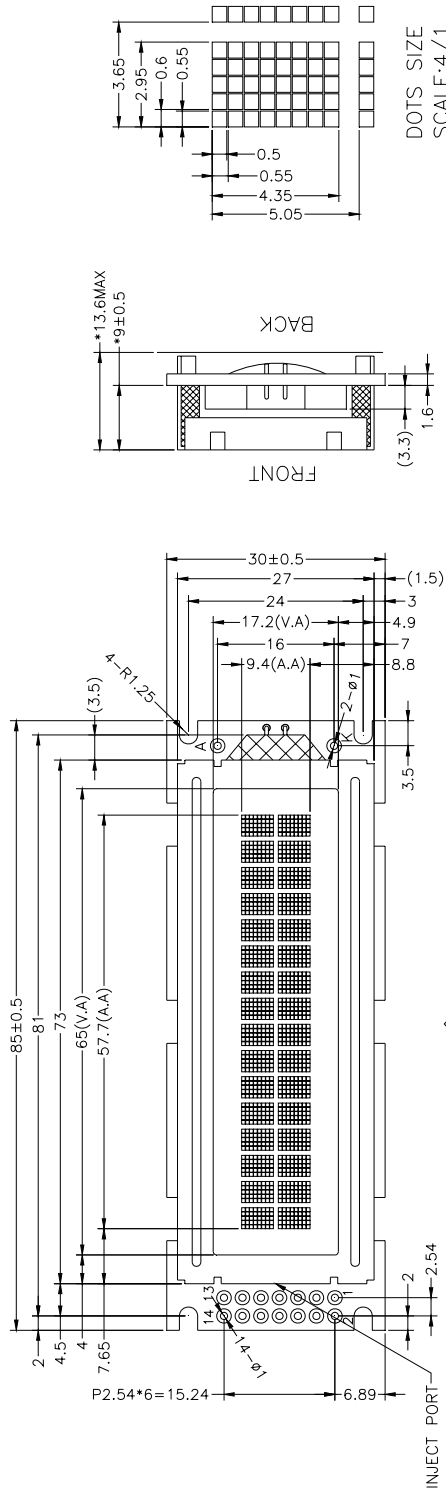

Figure 1 . Block Diagram

4. DIMENSIONAL OUTLINE



CONSTANT CURRENT: 15mA, 5.0V(REF.)
 BACKLIGHT DRIVER CIRCUIT DIAGRAM

PIN	1	2	3	4	5	6	7
CONNECTION	VDD	VSS	VO	RS	R/W	E	DB0
PIN	8	9	10	11	12	13	14
CONNECTION	DB1	DB2	DB3	DB4	DB5	DB6	DB7

Remark: The white print is on the rear side of PCB only

5. PIN DESCRIPTION

No.	Symbol	Function
1	VDD	Power supply(+5.0V)
2	VSS	GND(0V)
3	V0	Supply voltage for LCD
4	RS	Register selection. (H: Data register L: Instruction register)
5	R/W	Read /write selection. (H: Read L: write)
6	E	Enable signal for chip
7~14	DB0~DB7	Data bus line

6. MAXIMUM ABSOLUTE LIMIT

Item	Symbol	MIN	MAX	Unit
Supply Voltage for Logic	V _{DD}	-0.3	7.0	V
Supply Voltage for LCD	V ₀	V _{DD} -10.0	V _{DD} +0.3	V
Input Voltage	V _{in}	-0.3	V _{DD} +0.3	V
Supply Current for Backlight	I _F (Ta = 25°C)	---	15	mA
Reverse Voltage for Backlight	V _R (Ta = 25°C)	---	5.0	V
Operating Temperature	Top	-20	70	°C
Storage Temperature	Tst	-30	80	°C

7. BACKLIGHT CHARACTERISTICS

LCD Module with Edge White LED Backlight

ELECTRICAL RATINGS

Ta = 25°C

Item	Symbol	Condition	Min	Typ	Max	Unit
Forward Voltage	V _F	I _F =20mA	3.0	3.1	3.4	V
Reverse Current	I _R	V _R =5.0V	---	10	---	uA
Luminous Intensity(Without LCD)	L _v	I _F =20mA	330	450	---	cd/m ²
Chromaticity Coordinates	X	I _F =20mA	0.30	---	0.35	
	Y		0.30			
Color	White					

Note:

For operation above 25°C, The I_{fm} & P_d must be derated, the Current derating is -0.36mA/°C for DC drive and -0.86mA/°C for Pulse drive, the power dissipation is -0.75mW/°C. The product working current must not more than the 60% of the I_{fm} or I_{fp} according to the working temperature

8. ELECTRICAL CHARACTERISTICS**8.1 DC characteristics ($V_{DD} = 4.5V - 5.5V$, $T_A = 25^\circ C$)**

Characteristics	Symbol	Limit			Unit	Test Condition
		Min.	Typ.	Max.		
Operating Current	I_{DD}	-	0.55	0.8	mA	External clock (Note)
Input High Voltage	V_{IH1}	2.5	-	VDD	V	Pins:(E, RS, R/W, DB0 - DB7) VDD=5V
Input Low Voltage	V_{IL1}	-0.3	-	0.6	V	
Input High Voltage	V_{IH2}	VDD-1	-	VDD	V	Pin OSC1
Input Low Voltage	V_{IL2}	-0.2	-	1.0	V	Pin OSC1
Input High Current	I_{IH}	-2.0	-	2.0	μA	Pins: (RS, R/W, DB0 - DB7) VDD = 5.0V
Input Low Current	I_{IL}	-20	-125	-250	μA	
Output High Voltage (TTL)	V_{OH1}	2.4	-	VDD	V	$I_{OH} = -0.1mA$ Pins: DB0 - DB7
Output Low Voltage (TTL)	V_{OL1}	-	-	0.4	V	$I_{OL} = 0.1mA$ Pins: DB0 - DB7
Output High Voltage (CMOS)	V_{OH2}	0.9VDD	-	VDD	V	$I_{OH} = -40\mu A$, Pins: CL1, CL2, M, D
Output Low Voltage (CMOS)	V_{OL2}	-	-	0.1VDD	V	$I_{OL} = 40\mu A$, Pins: CL1, CL2, M, D
Driver ON Resistance (COM)	R_{COM}	-	-	20	K Ω	$I_O = \pm 50\mu A$, $V_{LCD} = 4.0V$ Pins: COM1 - COM16
Driver ON Resistance (SEG)	R_{SEG}	-	-	30	K Ω	$I_O = \pm 50\mu A$, $V_{LCD} = 4.0V$ Pins: SEG1 - SEG40
LCD Voltage	V_{LCD}	3.0	-	8	V	VDD-V5, 1/4 bias or 1/5 bias

Note: $F_{clk} = 250KHz$, VDD = 5.0V, pin E = "L", RS, R/W, DB0 - DB7 are open, all outputs are no loads.

8.2 AC characteristics ($V_{DD} = 4.5V-5.5V, TA=25^{\circ}C$)

Write mode (writing data from MPU to SPLC780D1)

Characteristics	Symbol	Limit			Unit	Test Condition
		Min.	Typ.	Max.		
E Cycle Time	t_c	400	-	-	ns	Pin E
E Pulse Width	t_{pw}	150	-	-	ns	Pin E
E Rise/Fall Time	t_r, t_f	-	-	25	ns	Pin E
Address Setup Time	t_{SP1}	30	-	-	ns	Pins: RS, R/W, E
Address Hold Time	t_{HD1}	10	-	-	ns	Pins: RS, R/W, E
Data Setup Time	t_{SP2}	40	-	-	ns	Pins: DB0 - DB7
Data Hold Time	t_{HD2}	10	-	-	ns	Pins: DB0 - DB7

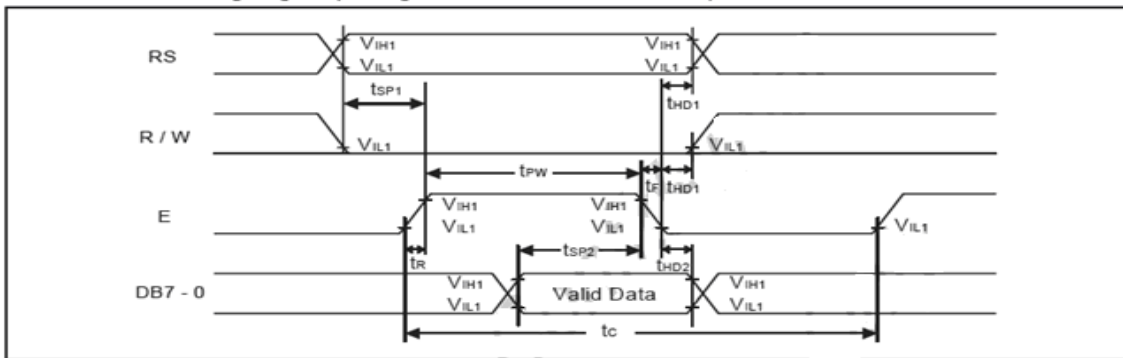

Read mode (reading data from SPLC780D1 to MPU)

Characteristics	Symbol	Limit			Unit	Test Condition
		Min.	Typ.	Max.		
E Cycle Time	t_c	400	-	-	ns	Pin E
E Pulse Width	t_{pw}	150	-	-	ns	Pin E
E Rise/Fall Time	t_r, t_f	-	-	25	ns	Pin E
Address Setup Time	t_{SP1}	30	-	-	ns	Pins: RS, R/W, E
Address Hold Time	t_{HD1}	10	-	-	ns	Pins: RS, R/W, E
Data Output Delay Time	t_o	-	-	100	ns	Pins: DB0 - DB7
Data hold time	t_{HD2}	5.0	-	-	ns	Pin DB0 - DB7

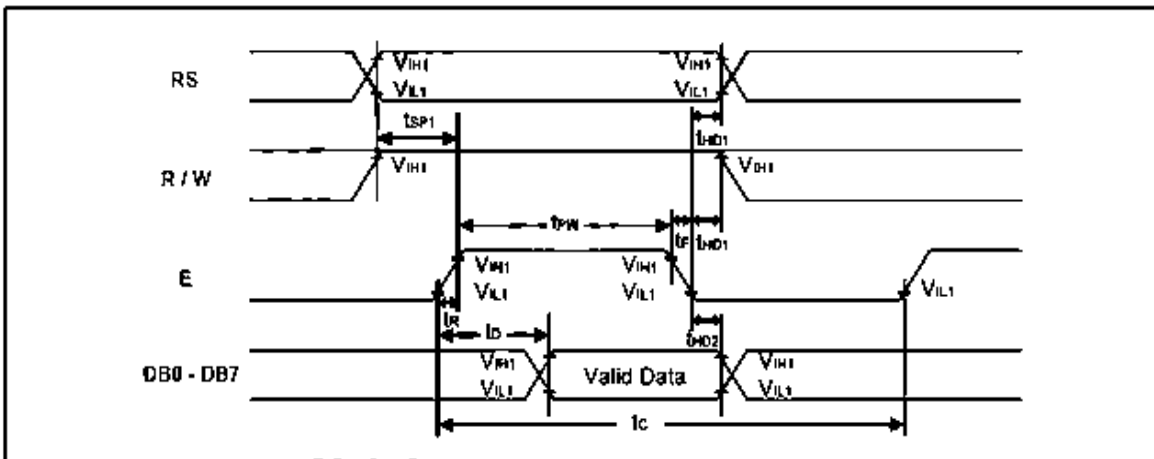

Interface mode with LCD driver

Characteristics	Symbol	Limit			Unit	Test Condition
		Min.	Typ.	Max.		
Clock pulse width high	t_{PWH}	800	-	-	ns	Pins: CL1, CL2
Clock pulse width low	t_{PWL}	800	-	-	ns	Pins: CL1, CL2
Clock setup time	t_{CSP}	500	-	-	ns	Pins: CL1, CL2
Data setup time	t_{DSP}	300	-	-	ns	Pins: D
Data hold time	t_{HD}	300	-	-	ns	Pins: D
M delay time	t_D	-1000	-	1000	ns	Pins: M

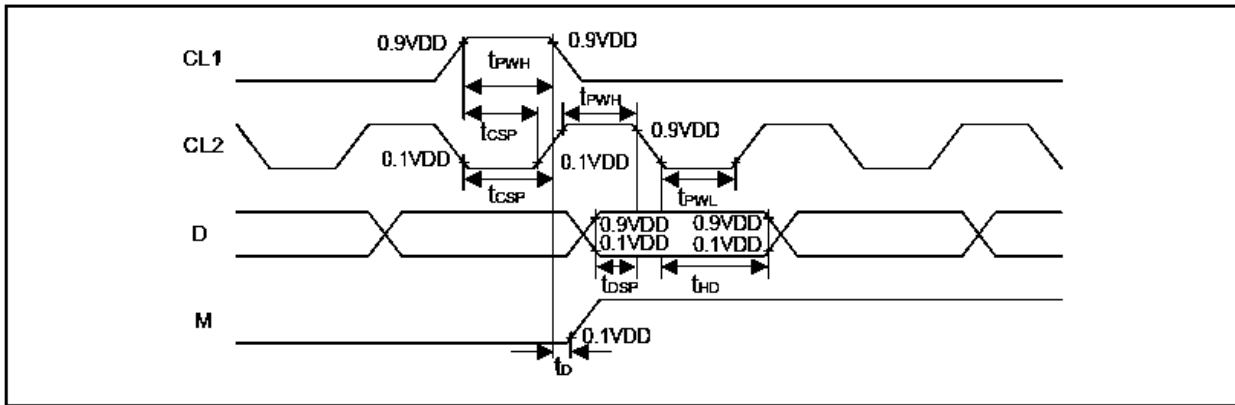

9. ELECTRO-OPTICAL CHARACTERISTICS

($V_{DD}=5.0V, T_a = 25^{\circ}C$)

Item	Symbol	Condition	Min	Typ	Max	Unit
Operating Voltage	Vop	Ta = -20°C	4.1	4.3	4.5	V
		Ta = 25°C	3.7	3.9	4.1	
		Ta = 70°C	3.4	3.5	3.7	
Response time	Tr	Ta = 25°C	---	185	---	ms
	Tf		---	200	---	ms
Contrast	Cr	Ta = 25°C $\theta_x = \theta_y = 0$	---	4	---	---
Viewing angle range	θ_x	Cr ≥ 2	-35	---	+35	deg
	θ_y		-45	---	+40	deg

$$Cr = \frac{\text{Brightness of non-selected segment}(B2)}{\text{Brightness of selected segment}(B1)}$$

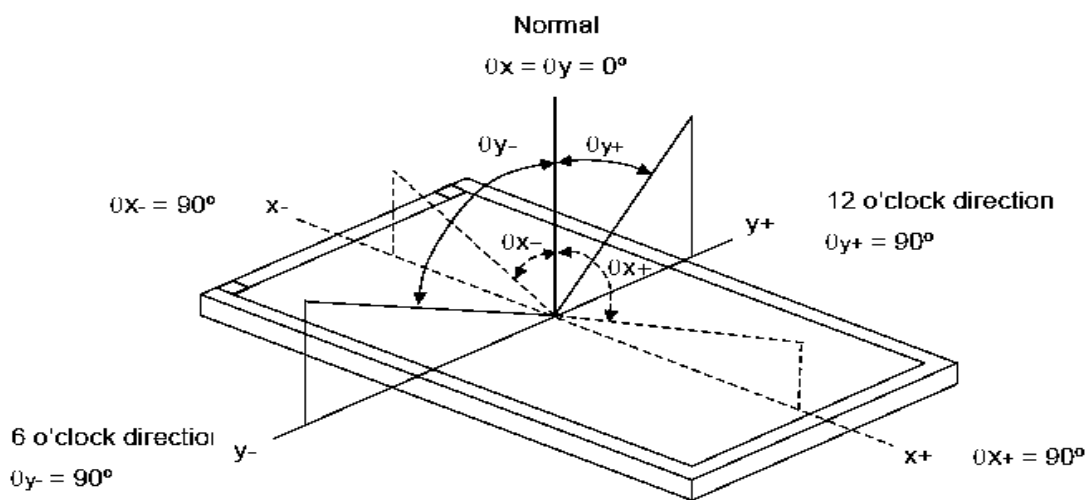
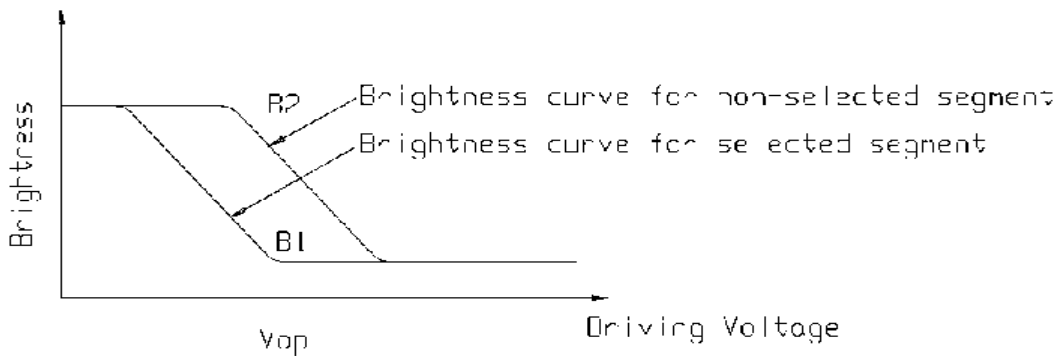

10. CONTROL AND DISPLAY INSTRUCTION

Instruction	Instruction Code										Description	Execution time (Temp = 25°C)		
	RS	RW	DB7	DB6	DB5	DB4	DB3	DB2	DB1	DB0		Fosc= 190KHz	Fosc= 270KHz	Fosc= 350KHz
Clear Display	0	0	0	0	0	0	0	0	0	1	Write "20H" to DDRAM and set DDRAM address to "00H" from AC	2.16ms	1.52ms	1.18ms
Return Home	0	0	0	0	0	0	0	0	1	-	Set DDRAM address to "00H" from AC and return cursor to its original position if shifted. The contents of DDRAM are not changed.	2.16ms	1.52ms	1.18ms
Entry Mode Set	0	0	0	0	0	0	0	1	I/D	S	Assign cursor moving direction and enable the shift of entire display	53μs	38μs	29μs
Display ON/OFF Control	0	0	0	0	0	0	1	D	C	B	Set display (D), cursor(C), and blinking of cursor(B) on/off control bit.	53μs	38μs	29μs
Cursor or Display Shift	0	0	0	0	0	1	S/C	R/L	-	-	Set cursor moving and display shift control bit, and the direction, without changing of DDRAM data.	53μs	38μs	29μs
Function Set	0	0	0	0	1	DL	N	F	-	-	Set interface data length (DL: 8-bit/4-bit), numbers of display line (N: 2-line/1-line) and, display font type (F:5x10 dots/5x8 dots)	53μs	38μs	29μs
Set CGRAM Address	0	0	0	1	AC5	AC4	AC3	AC2	AC1	AC0	Set CGRAM address in address counter.	53μs	38μs	29μs
Set DDRAM Address	0	0	1	AC6	AC5	AC4	AC3	AC2	AC1	AC0	Set DDRAM address in address counter	53μs	38μs	29μs
Read Busy Flag and Address Counter	0	1	BF	AC6	AC5	AC4	AC3	AC2	AC1	AC0	Whether during internal operation or not can be known by reading BF. The contents of address counter can also be read.			
Write Data to RAM	1	0	D7	D6	D5	D4	D3	D2	D1	D0	Write data into internal RAM (DDRAM/CGRAM).	53μs	38μs	29μs
Read Data from RAM	1	1	D7	D6	D5	D4	D3	D2	D1	D0	Read data from internal RAM (DDRAM/CGRAM).	53μs	38μs	29μs

Note1: "-" : don't care

Note2: In the operation condition under -20°C ~ 75°C, the maximum execution time for majority of instruction sets is 100μs, except two instructions, "Clear Display" and "Return Home", in which maximum execution time can take up to 4.1ms.

11. FONT CHARACTERISTIC

Upper 4 bit Lower 4 bit	LLLL	LLLH	LLHL	LLHH	LHLL	LHLH	LHHL	LHHH	HLLL	HLLH	HLHL	HLHH	HHLL	HHLH	HHHL	HHHH
LLLL				0	1	2	3	4	5	6	7	8	9	A	B	C
LLLH			!	1	2	3	4	5	6	7	8	9	A	B	C	D
LLHL			"	2	3	4	5	6	7	8	9	A	B	C	D	E
LLHH			#	3	4	5	6	7	8	9	A	B	C	D	E	F
LHLL			\$	4	5	6	7	8	9	A	B	C	D	E	F	G
LHLH			%	5	6	7	8	9	A	B	C	D	E	F	G	H
LHHL			&	6	7	8	9	A	B	C	D	E	F	G	H	I
LHHH			'	7	8	9	A	B	C	D	E	F	G	H	I	J
HLLL			(8	9	A	B	C	D	E	F	G	H	I	J	K
HLLH)	9	A	B	C	D	E	F	G	H	I	J	K	L
HLHL			*	A	B	C	D	E	F	G	H	I	J	K	L	M
HLHH			+	B	C	D	E	F	G	H	I	J	K	L	M	N
HHLL			,	C	D	E	F	G	H	I	J	K	L	M	N	O
HHLH			-	D	E	F	G	H	I	J	K	L	M	N	O	P
HHHL			.	E	F	G	H	I	J	K	L	M	N	O	P	Q
HHHH			/	F	G	H	I	J	K	L	M	N	O	P	Q	R

12. PRECAUTION FOR USING LCD/LCM

LCD/LCM is assembled and adjusted with a high degree of precision. Do not attempt to make any alteration or modification. The followings should be noted.

General Precautions:

1. LCD panel is made of glass. Avoid excessive mechanical shock or applying strong pressure onto the surface of display area.
2. The polarizer used on the display surface is easily scratched and damaged. Extreme care should be taken when handling. To clean dust or dirt off the display surface, wipe gently with cotton, or other soft material soaked with isopropyl alcohol, ethyl alcohol or trichlorotrifluoroethane, do not use water, ketone or aromatics and never scrub hard.
3. Do not tamper in any way with the tabs on the metal frame.
4. Do not make any modification on the PCB without consulting DISPLAY.
5. When mounting a LCM, make sure that the PCB is not under any stress such as bending or twisting. Elastomer contacts are very delicate and missing pixels could result from slight dislocation of any of the elements.
6. Avoid pressing on the metal bezel, otherwise the elastomer connector could be deformed and lose contact, resulting in missing pixels and also cause rainbow on the display.
7. Be careful not to touch or swallow liquid crystal that might leak from a damaged cell. Any liquid crystal adheres to skin or clothes, wash it off immediately with soap and water.

Static Electricity Precautions:

1. CMOS-LSI is used for the module circuit; therefore operators should be grounded whenever he/she comes into contact with the module.
2. Do not touch any of the conductive parts such as the LSI pads; the copper leads on the PCB and the interface terminals with any parts of the human body.
3. Do not touch the connection terminals of the display with bare hand; it will cause disconnection or defective insulation of terminals.
4. The modules should be kept in anti-static bags or other containers resistant to static for storage.
5. Only properly grounded soldering irons should be used.
6. If an electric screwdriver is used, it should be grounded and shielded to prevent sparks.
7. The normal static prevention measures should be observed for work clothes and working benches.
8. Since dry air is inductive to static, a relative humidity of 50-60% is recommended.

Soldering Precautions:

1. Soldering should be performed only on the I/O terminals.
2. Use soldering irons with proper grounding and no leakage.
3. Soldering temperature: 270~300°C
4. Soldering time: 2 to 3 second.
5. Use eutectic solder with resin flux filling.
6. If flux is used, the LCD surface should be protected to avoid spattering flux.
7. Flux residue should be removed.

operation Precautions:

1. The viewing angle can be adjusted by varying the LCD driving voltage V_o .
2. Since applied DC voltage causes electro-chemical reactions, which deteriorate the display, the applied pulse waveform should be a symmetric waveform such that no DC component remains. Be sure to use the specified operating voltage.
3. Driving voltage should be kept within specified range; excess voltage will shorten display life.
4. Response time increases with decrease in temperature.
5. Display color may be affected at temperatures above its operational range.
6. Keep the temperature within the specified range usage and storage. Excessive temperature and humidity could cause polarization degradation, polarizer peel-off or generate bubbles.
7. For long-term storage over 40°C is required, the relative humidity should be kept below 60%, and avoid direct sunlight.

Limited Warranty

DISPLAY LCDs and modules are not consumer products, but may be incorporated by DISPLAY's customers into consumer products or components thereof, DISPLAY does not warrant that its LCDs and components are fit for any such particular purpose.

1. The liability of DISPLAY is limited to repair or replacement on the terms set forth below. DISPLAY will not be responsible for any subsequent or consequential events or injury or damage to any personnel or user including third party personnel and/or user. Unless otherwise agreed in writing between DISPLAY and the customer, DISPLAY will only replace or repair any of its LCD which is found defective electrically or visually when inspected in accordance with DISPLAY general LCD inspection standard . (Copies available on request)
2. No warranty can be granted if any of the precautions state in handling liquid crystal display above has been disregarded. Broken glass, scratches on polarizer mechanical damages as well as defects that are caused accelerated environment tests are excluded from warranty.
3. In returning the LCD/LCM, they must be properly packaged; there should be detailed description of the failures or defect.

13. APPENDIX

The jumpers' function

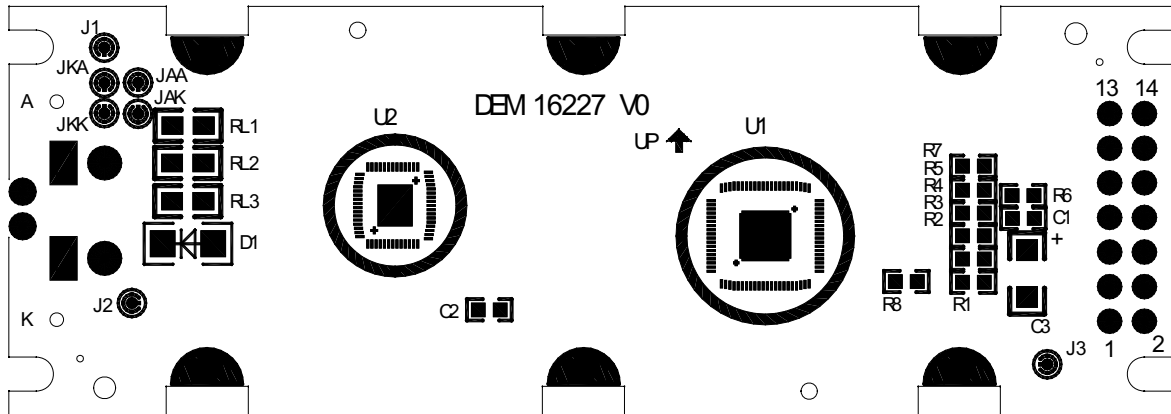

J1: Select the VDD or the input interface of A

J2: Select the VSS or the input interface of K

JAK,JAA: Which PIN of the backlight connect the input interface of A

JAK,JKK: Which PIN of the backlight connect the input interface of K

J3: Whether the bezel connect the VSS