

- 1
- 2
- 3
- 4
- 5
- 6
- 7
- 8
- 9
- 10
- 11
- 12
- 13
- 14
- 15
- 16
- 17
- 18

BODY

Die-cast zinc alloy.

COLOUR

Black epoxy resin coating, matte finish.

PLUNGER

Zinc-plated steel.

LEVER

High-resilience polyamide based (PA) technopolymer, black colour, matte finish.

FEATURES AND APPLICATIONS

GN 612.9 lever indexing plungers are used when the plunger must be retracted quickly.

By rotating through 180° the lifting lever stops on the notch, keeping the plunger in the retracted position.

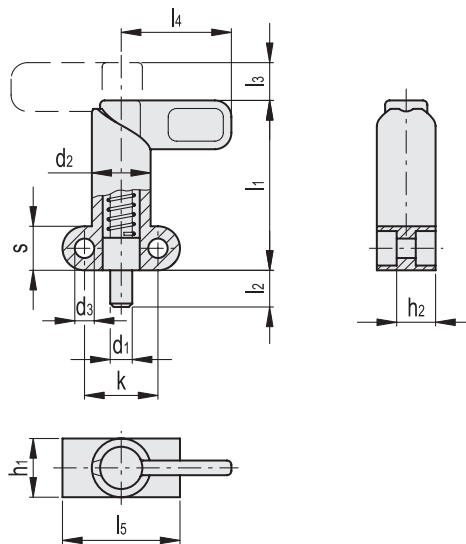
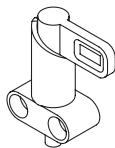

Code	Description	d1											s	[N]*	[N]#	Δ△
		Plunger -0.05	d2	d3	h1	h2	k	l1	l2	l3	l4	l5				
GN.34461	GN 612.9-6-10-16-SW	6	16	5.5	16	10.5	20	46	10	10	30	32	12	12	32	57
GN.34458	GN 612.9-6-16-16-SW	6	16	5.5	16	10.5	20	46	16	10	30	32	12	12	32	57
GN.34462	GN 612.9-8-10-16-SW	8	16	5.5	16	10.5	20	46	10	10	30	32	12	12	32	58
GN.34463	GN 612.9-8-12-20-SW	8	20	5.5	20	14.5	22	57	12	12	37	37	15	21	58	120
GN.34459	GN 612.9-8-16-16-SW	8	16	5.5	16	10.5	20	46	16	10	30	32	12	12	32	58
GN.34460	GN 612.9-8-18-20-SW	8	20	5.5	20	14.5	22	57	18	12	37	37	15	21	58	120
GN.34464	GN 612.9-10-10-16-SW	10	16	5.5	16	10.5	20	46	10	10	30	32	12	12	32	121
GN.34465	GN 612.9-10-12-20-SW	10	20	5.5	20	14.5	22	57	12	12	37	37	15	21	58	122
GN.34467	GN 612.9-10-16-16-SW	10	16	5.5	16	10.5	20	46	16	10	30	32	12	12	32	121
GN.34468	GN 612.9-10-18-20-SW	10	20	5.5	20	14.5	22	57	18	12	37	37	15	21	58	122
GN.34466	GN 612.9-12-12-20-SW	12	20	5.5	20	14.5	22	57	12	12	37	37	15	21	58	127
GN.34469	GN 612.9-12-18-20-SW	12	20	5.5	20	14.5	22	57	18	12	37	37	15	21	58	127

* Spring preload

Spring maximum load