

0603ESDA-MLP1

ESD suppressor



Product features

- Ultra-low capacitance (0.05 pF) ideal for high speed data applications
- Provides Electro Static Discharge (ESD) protection with fast response time (<1 ns) allowing equipment to pass IEC 61000-4-2 Level 4 test
- Single-line, bi-directional device
- 0603 (1608 metric) compact design utilizes less board space

Applications

- ESD port protection for mobile/smart phones
- Game console ESD port protection
- High speed ESD data port protection
- Set-top-boxes
- Tablets, notebooks, netbooks, laptops
- High definition television (HDTV)
- Media players
- Digital cameras
- Medical equipment
- Computers and peripherals ESD port protection
- Consumer electronics

Ordering information

- Specify part number and packaging suffix (e.g. 0603ESDA-MLP1) 0603ESDA-MLP = part number, 1 = form designation)

Packaging suffixes

- 1 (Dip termination, tape and reel, 5000 parts per 7" diameter reel)

Environmental compliance



Product specifications

Part number ⁴	Rated voltage (V _{dc}) maximum	Clamping voltage ¹ (V) typical	Trigger voltage ² (V) typical	Capacitance @ 1 MHz (pF) typical	Capacitance @ 1 MHz (pF) maximum	Attenuation change (0–6 GHz) (dB) typical	Leakage current @ 12 V _{dc} (nA) typical	ESD capability IEC61000-4-2 Direct discharge (kV) typical	ESD capability IEC61000-4-2 Air discharge (kV) typical	ESD pulse withstand ³ typical
0603ESDA-MLP1	30	35	300	0.05	0.15	-0.2	<1.0	8.0	15	>1000

1. Clamping voltage: Per IEC61000-4-2, Level 4 waveform (8 kV direct 30 A) measured 30 ns after initial pulse.

2. Trigger voltage: Trigger measurement made using transmission line pulse (TLP) method.

3. Minor shifting in characteristics may be observed over multiple ESD pulses at very rapid rate.

4. Part number definition: 0603ESDA-MLP1

0603ESDA= Product code and size

-MLP= Form designation

-1= Packaging suffix

Dimensions—mm

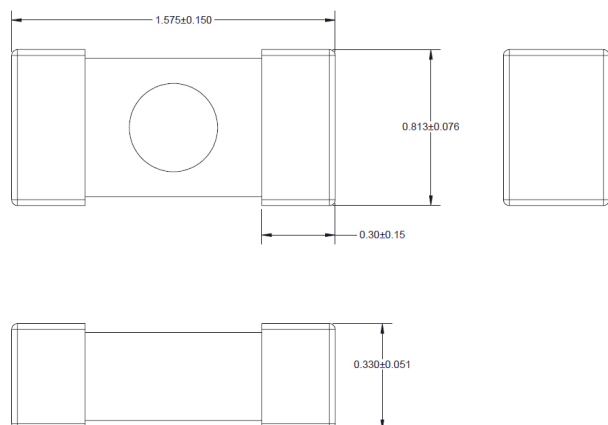

Recommended pad layout

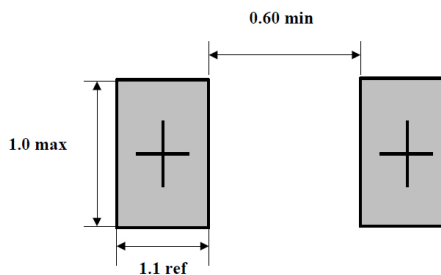

Design considerations

The location in the circuit for the 0603ESDA-MLP has to be carefully determined. For better performance, the device should be placed as close to the signal input as possible and ahead of any other component. Due to the high current associated with an ESD event, it is recommended to use a “0-stub” pad design (pad directly on the signal/data line and second pad directly on common ground).

General specifications

Operating temperature: - 55 °C to +125 °C

Storage temperature (component): - 55 °C to +125 °C

Chemical resistance: ASTM D-543

Vibration: MIL-STD-202F method 201A

Humidity (steady state): MIL-STD-883, method 1004.7

Thermal shock: MIL-STD-202F method 107G

Solderability: MIL-STD-202 Method 208

ESD endurance: IEC 61000-4-2

Wave solder profile

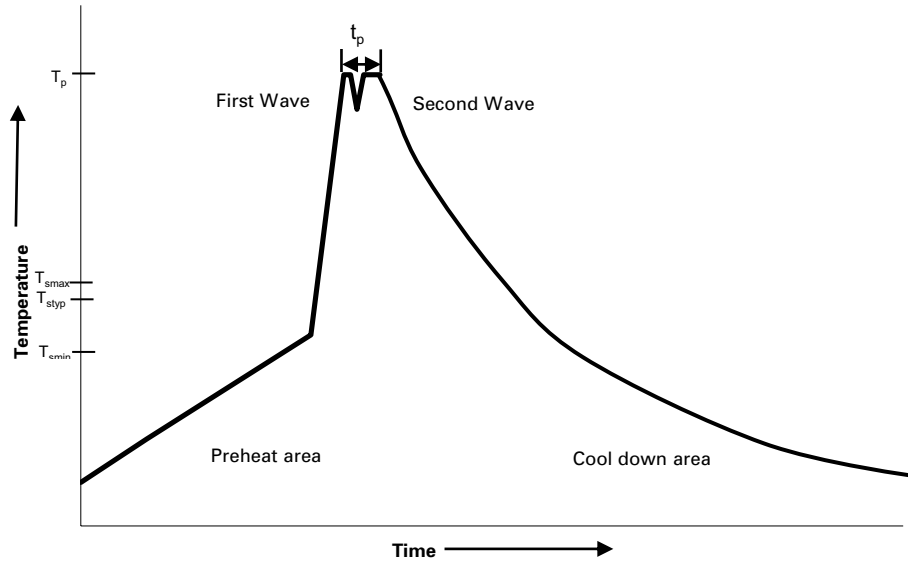

Reference EN 61760-1:2006

Profile feature	Standard SnPb solder	Lead (Pb) free solder
Preheat		
• Temperature min. (T_{smin})	100 °C	100 °C
• Temperature typ. (T_{styp})	120 °C	120 °C
• Temperature max. (T_{smax})	130 °C	130 °C
• Time (T_{smin} to T_{smax}) (t_s)	70 seconds	70 seconds
Δ preheat to max Temperature	150 °C max.	150 °C max.
Peak temperature (T_p)*	235 °C – 260 °C	250 °C – 260 °C
Time at peak temperature (t_p)	10 seconds max 5 seconds max each wave	10 seconds max 5 seconds max each wave
Ramp-down rate	~ 2 K/s min ~3.5 K/s typ ~5 K/s max	~ 2 K/s min ~3.5 K/s typ ~5 K/s max
Time 25 °C to 25 °C	4 minutes	4 minutes

Manual solder

+350 °C (4-5 seconds by soldering iron), generally manual/hand soldering is not recommended.

Solder reflow profile

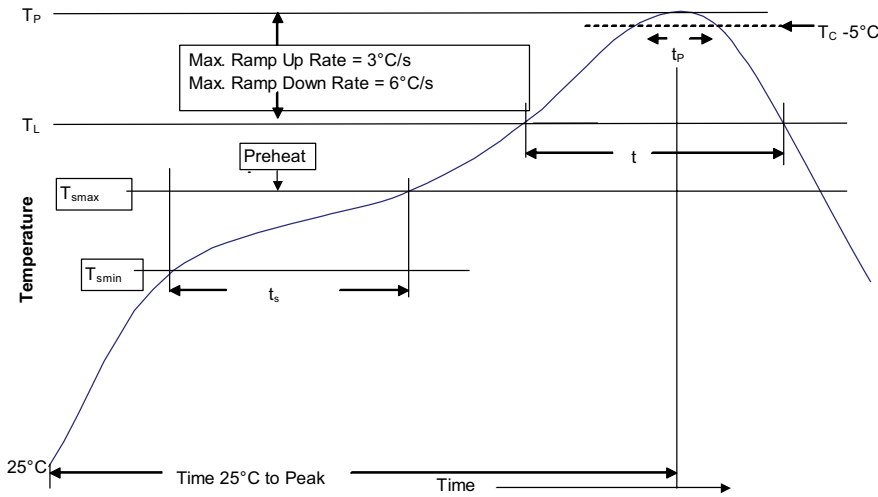

Table 1 - Standard SnPb solder (T_c)

Package thickness	Volume mm ³ <350	Volume mm ³ ≥350
<2.5 mm)	235 °C	220 °C
≥2.5 mm	220 °C	220 °C

Table 2 - Lead (Pb) free solder (T_c)

Package thickness	Volume mm ³ <350	Volume mm ³ 350 - 2000	Volume mm ³ >2000
<1.6 mm	260 °C	260 °C	260 °C
1.6 – 2.5 mm	260 °C	250 °C	245 °C
>2.5 mm	250 °C	245 °C	245 °C

Reference J-STD-020

Profile feature	Standard SnPb solder	Lead (Pb) free solder
Preheat and soak	<ul style="list-style-type: none"> Temperature min. (T_{smin}) Temperature max. (T_{smax}) Time (T_{smin} to T_{smax}) (t_s) 	<ul style="list-style-type: none"> 100 °C 150 °C 60-120 seconds
Ramp up rate T_L to T_p	3 °C/ second max.	3 °C/ second max.
Liquidous temperature (T_L) Time (t_L) maintained above T_L	<ul style="list-style-type: none"> 183 °C 60-150 seconds 	<ul style="list-style-type: none"> 217 °C 60-150 seconds
Peak package body temperature (T_p)*	Table 1	Table 2
Time (t_p)* within 5 °C of the specified classification temperature (T_c)	20 seconds*	30 seconds*
Ramp-down rate (T_p to T_L)	6 °C/ second max.	6 °C/ second max.
Time 25 °C to peak temperature	6 minutes max.	8 minutes max.

* Tolerance for peak profile temperature (T_p) is defined as a supplier minimum and a user maximum.

Life Support Policy: Eaton does not authorize the use of any of its products for use in life support devices or systems without the express written approval of an officer of the Company. Life support systems are devices which support or sustain life, and whose failure to perform, when properly used in accordance with instructions for use provided in the labeling, can be reasonably expected to result in significant injury to the user.

Eaton reserves the right, without notice, to change design or construction of any products and to discontinue or limit distribution of any products. Eaton also reserves the right to change or update, without notice, any technical information contained in this bulletin.

Eaton
Electronics Division
1000 Eaton Boulevard
Cleveland, OH 44122
United States
Eaton.com/electronics

© 2021 Eaton
All Rights Reserved
Printed in USA
Publication No. ELX1071 BU-ELX21072
July 2021

Eaton is a registered trademark.

All other trademarks are property of their respective owners.

Follow us on social media to get the latest product and support information.

