

PRODUKTDATENBLATT

POLO-KAL NG Abzweig 160/160/87

Artikel-Nr. 02247

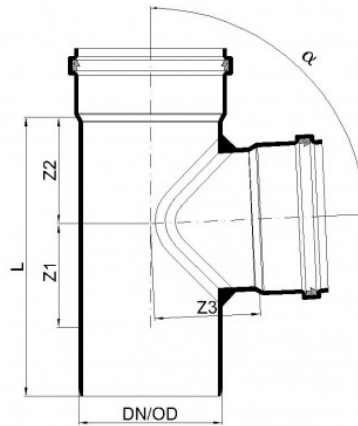
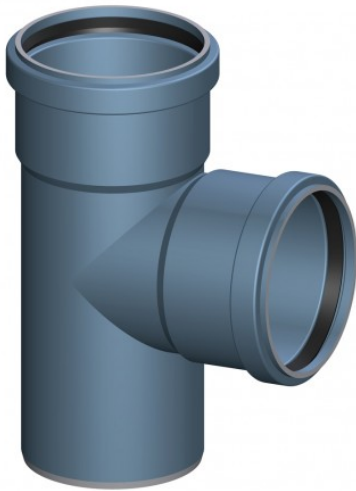

PURE
PROGRESS / poloplast

Technische Daten

DN/OD	160
DN/OD2	160
Winkel α	87,5°
Länge L	310 mm
Z1	115 mm
Z2	118 mm
Z3	118 mm
Gewicht	1,72 kg/Stk.
Verpackungseinheit	5 Stk.