

Solid State Relays Industrial, 1Phase Peak Switching Types RM1C

CARLO GAVAZZI



- Ideal for switching of transformers and other highly inductive loads
- Direct copper bonding (DCB) technology
- Thyristor power units
- LED indication
- Clip-on IP20 protection cover
- Housing free of moulding mass
- Self lifting terminals
- Operational ratings up to 50AACrms and 600VAC
- Non repetitive voltage up to 1400Vp
- Opto isolation: 4000 VACrms

Product Description

The peak switching SSR is primarily used for transformer applications. By applying DC control voltage, the output semiconductor is activated at the peak of the line voltage.

When the control voltage is removed, the semiconductor switches OFF, when load current crosses zero. The LED indicates when the output is activated.

Ordering Key

RM 1 C 60 D 50

Solid State Relay
Number of poles
Switching mode
Rated operational voltage
Control voltage
Rated operational current

Type Selection

Switching mode	Rated operational voltage	Control voltage	Rated operational current
C: Peak Switching	40: 400 VACrms 60: 600 VACrms	D: 4.25 - 32 VDC	25: 25 AACrms 50: 50 AACrms

Selection Guide

Rated operational voltage	Non-rep. voltage	Control voltage	Rated operational current	
			25 AACrms	50 AACrms
400 VACrms	800 V _p	4.25 - 32 VDC	RM1C40D25	RM1C40D50
600 VACrms	1400 V _p	4.25 - 32 VDC	RM1C60D25	RM1C60D50

General Specifications

	RM1C40D..	RM1C60D..
Operational voltage range	90 to 440 VACrms	150 to 660 VACrms
Non-rep. peak voltage	800 V _p	1400 V _p
Zero voltage turn-on	< 10 V	< 10 V
Operational frequency range	45 to 65 Hz	45 to 65 Hz
Approvals	UL, cUL, CSA*	UL, cUL, CSA*
CE-marking	Yes**	Yes**

* CSA approval pending

** Heatsink must be connected to ground for 600V types



Input Specifications

Control voltage	4.25 - 32 VDC
Pick up voltage	4.0 VDC
Drop out voltage	3.0 VDC
Max. input current	18 mA
Response time pick up	14 ms
Power output	14 ms
Response time drop out	10 ms
Power output	10 ms

Functional Diagram

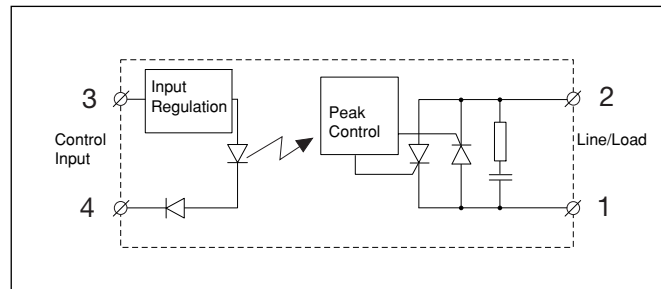

Output Specifications

	RM1C...25	RM1C...50
Rated operational current AC51 @ Ta=25°C	25 Arms	50 Arms
AC56a @ Ta=25°C	10 Arms	20 Arms
Min. operational current	150 mA	150 mA
Rep. overload current t=1 s	55 A	125 A
Non-rep. surge current t=10 ms	250 A _p	600 A _p
Off-state leakage current @ rated voltage and frequency	< 3 mA	< 3 mA
I ² t for fusing t=1-10 ms	< 310 A ² s	< 1800 A ² s
Critical di/dt @ 50 Hz	100 A/μs	100 A/μs
On-state voltage drop @ rated current	1.4 V _{rms}	1.4 V _{rms}
Critical dV/dt off-state min.	2kV/μs	2kV/μs

Heatsink Dimensions (load current versus ambient temperature)

RM1C...25

Load current [A]	Thermal resistance [K/W]						Power dissipation [W]	T _A Ambient temp. [°C]
	20	30	40	50	60	70		
25.0	2.70	2.34	1.98	1.61	1.25	0.89	28	
22.5	3.10	2.69	2.28	1.86	1.45	1.04	24	
20.0	3.61	3.13	2.65	2.18	1.70	1.23	21	
17.5	4.26	3.70	3.14	2.59	2.03	1.47	18	
15.0	5.14	4.47	3.80	3.14	2.47	1.80	15	
12.5	6.38	5.56	4.73	3.91	3.09	2.27	12	
10.0	8.25	7.19	6.14	5.08	4.02	2.97	9	
7.5	11.4	9.94	8.49	7.04	5.59	4.14	7	
5.0	17.7	15.4	13.2	11.0	8.74	6.51	4	
2.5	-	-	-	-	18.2	13.6	2	

RM1C...50

Load current [A]	Thermal resistance [K/W]						Power dissipation [W]	T _A Ambient temp. [°C]
	20	30	40	50	60	70		
50.0	1.03	0.86	0.70	0.53	0.37	0.20	61	
45.0	1.27	1.09	0.90	0.71	0.52	0.33	53	
40.0	1.54	1.32	1.10	0.89	0.67	0.45	46	
35.0	1.85	1.59	1.34	1.08	0.82	0.57	39	
30.0	2.26	1.95	1.65	1.34	1.03	0.72	33	
25.0	2.85	2.47	2.08	1.70	1.32	0.94	26	
20.0	3.73	3.24	2.75	2.26	1.77	1.27	20	
15.0	5.22	4.54	3.86	3.19	2.51	1.83	15	
10.0	8.21	7.16	6.11	5.05	4.00	2.95	10	
5.0	17.2	15.0	12.9	10.7	8.51	6.33	5	

Junction to ambient thermal resistance, R _{th j-a}	< 20.0	K/W
Junction to case thermal resistance, R _{th j-c}	< 0.80	K/W
Case to heatsink thermal resistance, R _{th c-s}	< 0.20	K/W
Maximum allowable case temperature	100	deg.C
Maximum allowable junction temperature	125	deg.C

Junction to ambient thermal resistance, R _{th j-a}	< 20.0	K/W
Junction to case thermal resistance, R _{th j-c}	< 0.50	K/W
Case to heatsink thermal resistance, R _{th c-s}	< 0.20	K/W
Maximum allowable case temperature	100	deg.C
Maximum allowable junction temperature	125	deg.C

Heatsink Selection

Carlo Gavazzi Heatsink (see Accessories)	Thermal resistance...	...for power dissipation
No heatsink required	---	N/A
RHS 300	5.00 K/W	> 0 W
RHS 100	3.00 K/W	> 25 W
RHS 45A	2.70 K/W	> 60 W
RHS 45B	2.00 K/W	> 60 W
RHS 90	1.35 K/W	> 60 W
RHS 45A plus fan	1.25 K/W	> 0 W
RHS 45B plus fan	1.20 K/W	> 0 W
RHS 112	1.10 K/W	> 100 W
RHS 301	0.80 K/W	> 70 W
RHS 90 plus fan	0.45 K/W	> 0 W
RHS 112 plus fan	0.40 K/W	> 0 W
RHS 301 plus fan	0.25 K/W	> 0 W
Consult your distribution	> 0.25 K/W	N/A
Infinite heatsink - No solution	---	N/A

Housing Specifications

Weight	Approx. 60 g
Housing material	Noryl GFN 1, black
Baseplate	Aluminium
Relay	
Mounting screws	M5
Mounting torque	1.5-2.0 Nm
Control terminal	
Mounting screws	M3 x 9
Mounting torque	0.5 Nm
Power terminal	
Mounting screws	M5 x 9
Mounting torque	2.4 Nm

Dimensions

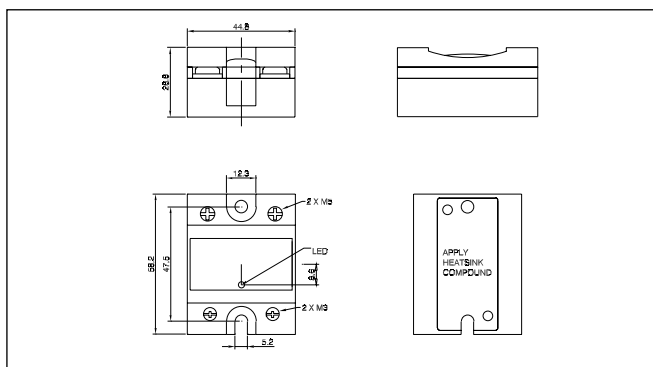

Insulation

Rated insulation voltage	
Input to output	≥ 4000 VACrms
Output to case	≥ 4000 VACrms

Applications

Timing

Initial turn-on

The line voltage must be present at least 1 period before the input voltage is applied.

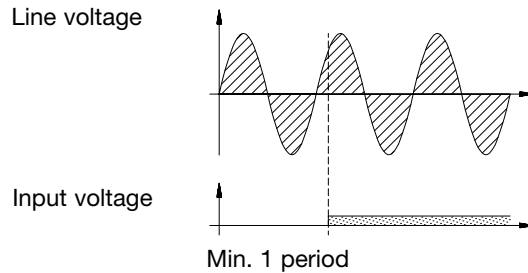

Repetitive turn-on

The input voltage must be lower than the drop out voltage limit at least 1 period before it is reapplied.

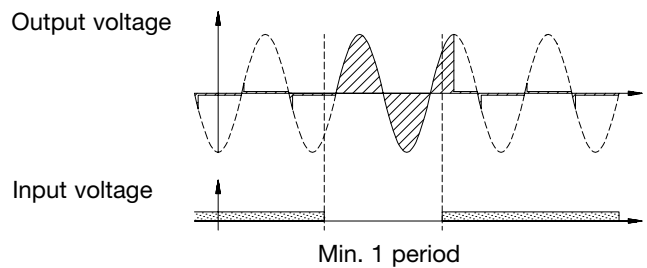

Overvoltage protection

As transformers can have varying stray inductances and stray capacitances, it is always advisable to use external overvoltage protection.

Varistor diameter: ≤ 20 mm
 Varistor voltage for 400 V SSR: 460 VAC (RV 02)
 Varistor voltage for 600V SSR: 680 VAC (RV 05)

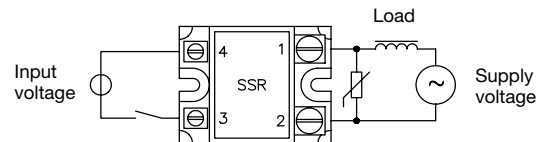

Thermal Specifications

Operating temperature range	-30° to +80°C
Storage temperature range	-40° to +100°C
Junction temperature	< 125°C