

98 42 937 0201



Pushing Performance

HARTING Han[®] GND



People | Power | Partnership

Features

- New: First connector for potential equalization
- Slim, space saving design
- Low cost plastic hoods and housings
- Colours: green and yellow
- Separate axial screw contacts can be terminated without any special tools directly to the wire.

Technical characteristics

<p>Specifications</p> <p>DIN EN 60 664-1 DIN EN 61 984</p> <p>Hoods/Housings</p> <p>Material - hoods/housings polycarbonate - seal NBR - cable seal polyamide</p> <p>Limiting temperatures -40 °C ... +85 °C</p> <p>Flammability acc. to UL 94 V 0</p> <p>Degree of protection according to DIN EN 60 529 for coupled connectors IP 65</p> <p>Mechanical working life ≥ 500 mating cycles</p> <p>Cable diameter 7.5 - 14 mm</p> <p>Modules</p> <p>Number of contacts 1</p> <p>Material polycarbonate</p> <p>Limiting temperatures -40 °C ... +125 °C</p> <p>Flammability acc. to UL 94 V 0</p> <p>Mechanical working life ≥ 500 mating cycles</p> <p>Crimp Contacts</p> <p>Material copper alloy</p> <p>Surface - hard-silver plated 3 µm Ag</p> <p>Contact resistance ≤ 0.3 mΩ</p> <p>Crimp terminal - wire gauge¹⁾ 10 ... 35 mm²</p> <p>Axial Screw Contacts</p> <p>Material copper alloy</p> <p>Surface - hard-silver plated 3 µm Ag</p> <p>Contact resistance ≤ 0.3 mΩ</p> <p>Screw terminal - wire gauge¹⁾ 10 ... 35 mm² - AWG 6 ... 2 - hexagonal driver SW 4 - tightening torque</p>	<table border="1" data-bbox="1189 1653 1469 1729"> <tr> <td>mm²</td> <td>10</td> <td>16</td> <td>25</td> <td>35</td> </tr> <tr> <td>Nm</td> <td>6</td> <td>6</td> <td>7</td> <td>8</td> </tr> </table>	mm ²	10	16	25	35	Nm	6	6	7	8
mm ²	10	16	25	35							
Nm	6	6	7	8							

1) geometric wire gauge

Number of contacts

1

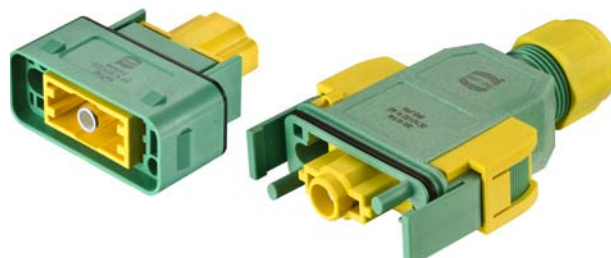

Mateable Potential Equalization

Identification Part-Number Drawings Dimensions in mm

Hood
top entry



09 14 001 0430

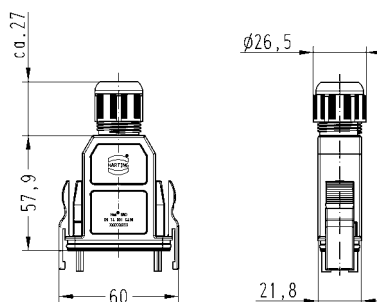

Unlocking Protection



09 14 000 9938

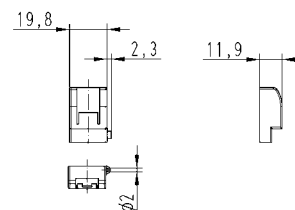

Housing



09 14 001 0330

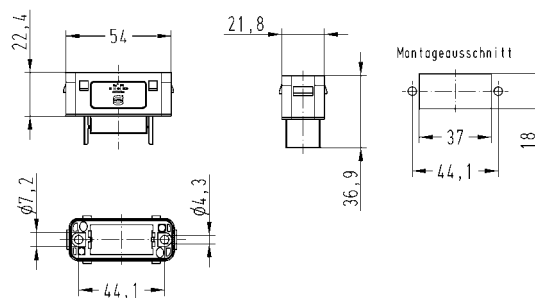

Hoods, cable to cable



09 14 001 0730

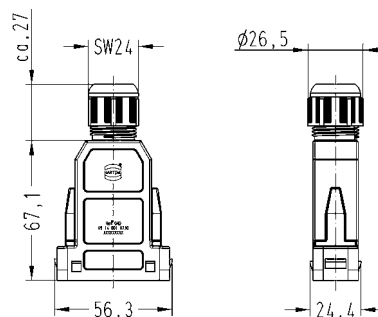





Gender changer / coupler
male / male

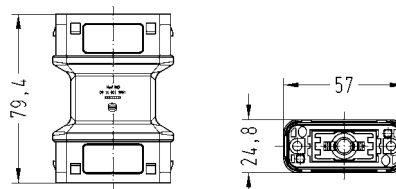

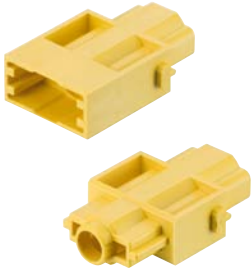
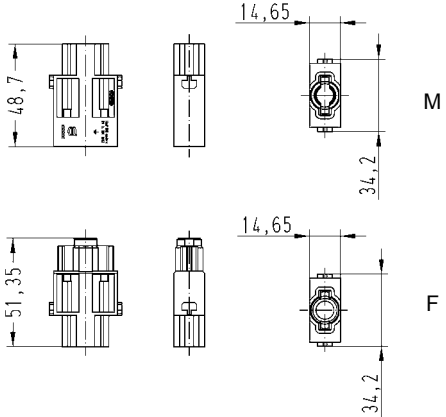

09 14 001 9901

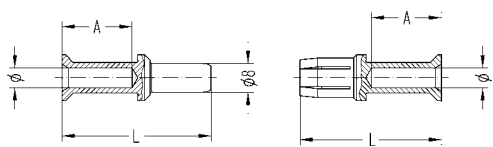

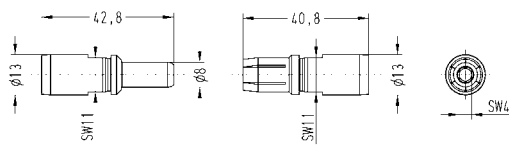
Identification	Part-Number		Drawings	Dimensions in mm
	Male module (M)	Female module (F)		
Modules order contacts separately 	09 14 001 3032	09 14 001 3132		M F

Identification	Wire gauge (mm ²)	Part number		Drawing	Dimensions in mm															
		Male contact	Female contact																	
Crimp contacts* 	10 16 25 35	09 11 000 6114 09 11 000 6116 09 11 000 6125 09 11 000 6135	09 11 000 6214 09 11 000 6216 09 11 000 6225 09 11 000 6235	 <table border="1" data-bbox="989 1198 1460 1366"> <thead> <tr> <th>Wire gauge</th> <th>Ø</th> <th>Stripping length (A)</th> </tr> </thead> <tbody> <tr> <td>10 mm²</td> <td>4.3</td> <td>19 mm</td> </tr> <tr> <td>16 mm²</td> <td>5.5</td> <td>19 mm</td> </tr> <tr> <td>25 mm²</td> <td>7.0</td> <td>19 mm</td> </tr> <tr> <td>35 mm²</td> <td>8.2</td> <td>16 mm</td> </tr> </tbody> </table> <p>for stranded wire acc. to IEC 60 228 Class 5</p>	Wire gauge	Ø	Stripping length (A)	10 mm ²	4.3	19 mm	16 mm ²	5.5	19 mm	25 mm ²	7.0	19 mm	35 mm ²	8.2	16 mm	
Wire gauge	Ø	Stripping length (A)																		
10 mm ²	4.3	19 mm																		
16 mm ²	5.5	19 mm																		
25 mm ²	7.0	19 mm																		
35 mm ²	8.2	16 mm																		
Axial screw contacts 	10-25 16-35	09 11 000 6112 09 11 000 6113	09 11 000 6212 09 11 000 6213	 <p>Stripping length 13 mm</p>																

Identification	Part number	Drawing	Dimensions in mm
Hex key SW 4 for axial setscrew with grip 	09 99 000 0363		
Bit 3/8" 	09 99 000 0370		

* Crimp zone acc. to DIN EN 46 235
 For further information see chapter 99 (Tools) in the main catalogue „Industrial Connectors Han®“

Assembly and construction

Assembly

Please use fine stranded wire (Class 5) which is recommend for the axial screw termination.

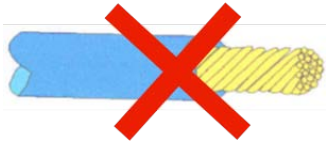

Do not twist the stripped wire!

1.

Please strip the wire. All suitable wire gauges have to be stripped with a length of 13 mm (acc. to Class 5 wire). Insert stripped wire into the terminal and push fully inside. Pay attention that all fine stranded wires are inserted in the contact.

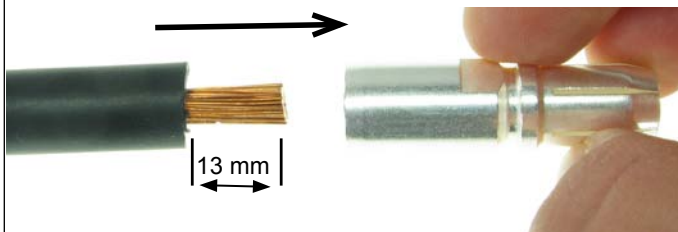

stripping length

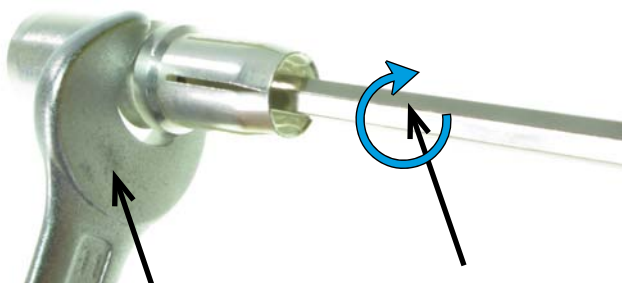
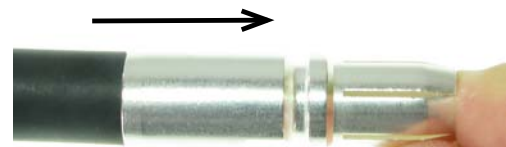

turn clockwise

Secure axial screw

2.

Please insert suitable torque key (SW 4) into the contact from mating side and turn the axial screw clockwise. For that purpose secure the axial screw with a spanner (SW 11). Tighten the screw to the specified torque value.

Assembly and construction



3. Insert the installed cable through the cable gland into the Han® GND housing! Push the axial screw contact into the module until you hear an audible click, which is the indicator that the contact snaps into position.



4. Push the module back into the housing and turn the cable gland clockwise.

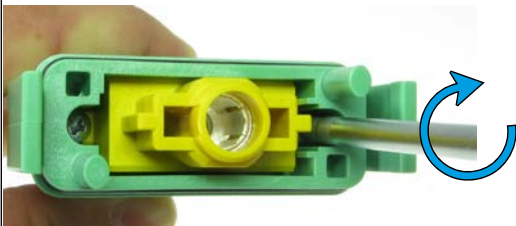

5. Mount the module in the housing with the enclosed screws.

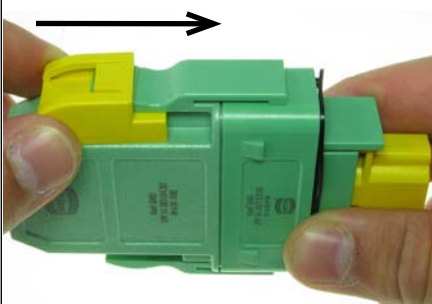

Protection against unintentional opening

1. Push the unlocking protection over the opening latches to prevent an unintentional opening (the connector can only be unmounted with a separate tool).

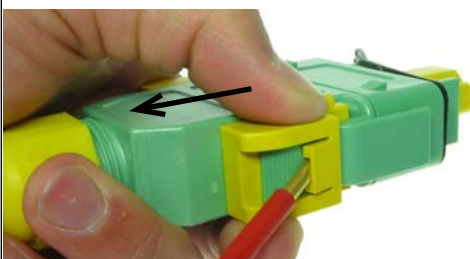

2. The removal of the unlocking protection can be done with a screwdriver for slotted screws (e.g. size 0.8 x 4.0). Insert the screwdriver in the unlocking protection slot and release the plastic latch until you are able to remove the unlocking protection with your fingers.



Pushing Performance

www.HARTING.com