

**Actuator/sensor cable, PUR**  
**Connection cable**  
**RSS12T-10/TXL**

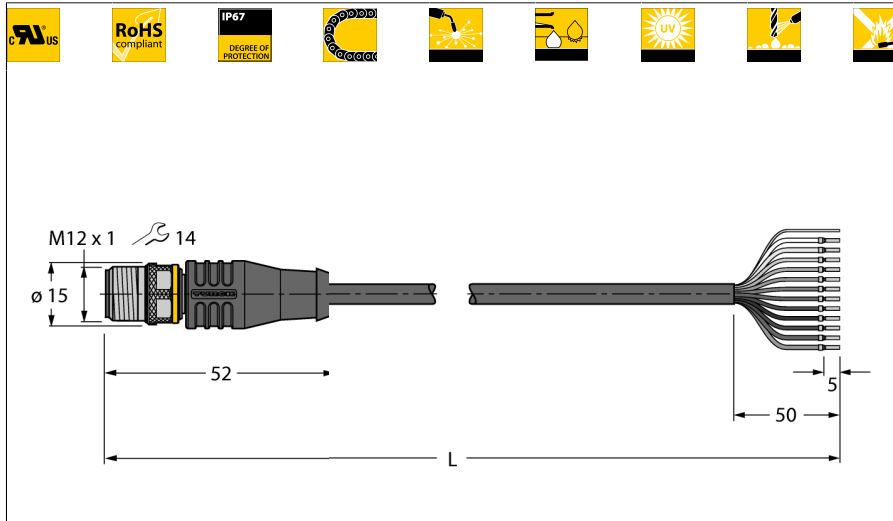

- Male M12, straight, 12-pin
- Shield on coupling nut/screw
- Sheath material: PUR, shielded
- Sheath color: black
- Qualified for drag chain use
- Resistant to weld splatter
- Resistant to chemicals, UV radiation and oils
- Flame retardant
- Free from halogen, silicone, PVC and LABS
- Particularly resistant to abrasion
- Approval: cULus
- RoHS conform
- Protection class IP67
- Cable length: 10 m

**Type designation** RSS12T-10/TXL  
**Ident no.** 6626925

**Connector A side**  
 Number of pins Connector, M12 1, Straight  
 12  
 Contacts Brass, CuZn, Gold-plated  
 Contact carriers Plastic, TPU, Black  
 Grip Plastic, TPU, Black  
 Coupling nut/screw Brass, CuZn, Nickel-plated  
 Protection class IP67, A + B side screwed together  
 Mechanical lifespan > 100 Mating cycles  
 Pollution degree 3  
 Tightening torque 0.8 ... 1 Nm  
 (observe max. torque of counter piece!)

**Cable Cross-section**

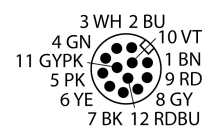
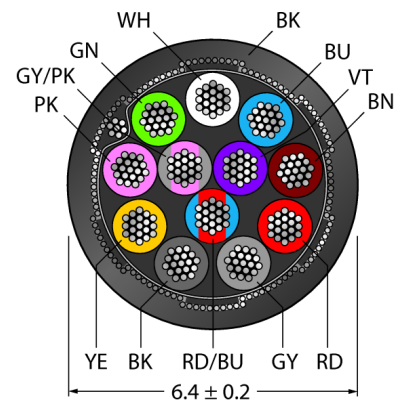

**General data**  
 Cable diameter 6.4 ± 0.20mm  
 Cable length 10 m  
 Cable quality PUR  
 Cable color Black  
 Core insulation PP  
 Core colors BN, BU, WH, GN, PK, YE, BK, GY, RD, VT, GY/PK, RD/BU  
 Core cross-section 12x0.14mm<sup>2</sup>  
 Arrangement of strands 18x0.1 mm  
 Shielding Aluminum foil, tinned copper wire

**Electrical features at +20 °C**  
 Current 1.5 A  
 Rated voltage 30 V  
 Insulation resistance > 30.5 MΩ/km  
 Test voltage 2000 V  
 Forward resistance max. 138 Ω/km

Drawing shows design status including hexagon coupling nut (Start of production CW42/2016).

**Circuit Diagram**

**Actuator/sensor cable, PUR**  
**Connection cable**  
**RSS12T-10/TXL**

**TURCK**

Industrial  
Automation

**Mechanical and chemical properties**

Max. tensile strength (static)	≤ 50 N/mm <sup>2</sup>
Max. tensile strength (dynamic)	≤ 20 N/mm <sup>2</sup>
Bending cycles	> 2 mil.
Bending radius (stationary laying)	> 5 x Ø
Bending radius (flexible use)	> 10 x Ø
Admissible acceleration	max. 5 m/s <sup>2</sup>
Admissible travel path, horizontal	5 m (at 5 m/s <sup>2</sup> )
Admissible travel path, vertical	2 m (at 5 m/s <sup>2</sup> )
Admissible traversing speed	3.3 m/s
Torsional stress	± 180 °/m
Ambient temperature	
Stationary	-50...+80°C
In motion	-25...+80°C
Drag chain operation	-25...+60°C

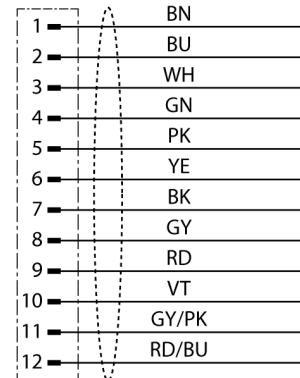

**Actuator/sensor cable, PUR**  
**Connection cable**  
**RSS12T-10/TXL**

**Accessories**

Type code	Ident no.	Description	
Torque-Wrench-Set-AS	6936170	Torque wrench set; handles with adjustable torque 0.4-1.0 Nm, torque wrench for M8 (SW9), fork wrench for M12 (SW 14)	
BLANK-LABEL-FOR-CORDESETS-TEL-TXL	6936206	Label for TEL and TXL cables, length: 18 mm, height: 4 mm, material: polycarbonate (PC), color: white, halogen-free and flame-retardant	