

QUANTA - Q2000/Q9000

4 DIGIT PROCESS METER, TRANSMITTER & CONTROLLER



- ✓ 10 or 15 V dc excitation output (Q9000E)
- ✓ $\pm 9,999$ -count display span
- ✓ Standard signal ranges of 4-20 mA, 10-50 mA, 1-5 V or 0-10 V
- ✓ Selectable current ranges from ± 1 to ± 50 mA
- ✓ Selectable voltage ranges from ± 0.5 to ± 20 V
- ✓ Built-in shunts and attenuators
- ✓ Zero adjustment to $\pm 100\%$ of readout
- ✓ Front-panel accessible fine-zero and fine-span adjustments
- ✓ 1 mV/count analog output
- ✓ Bright, 0.56 in. (14.2mm) LED display
- ✓ Automatic polarity
- ✓ Display hold and test
- ✓ 120/240 V ac, 5 V dc, 9-32 V dc or 26-56 V dc power
- ✓ Screw-terminal barrier strip
- ✓ 1/8 DIN case

Part Number Builder ?

(1) (2) (3) (4) (5) (6) (7)

Q -

Option Descriptions

(1) Display Resolution and Case Style

Select **2** for $\pm 1,999$ counts (3 1/2 digits), **3** for $\pm 1,999$ with INFINITY FAMILY BEZEL AND ADAPTER, **9** for $\pm 9,999$ counts (4 digits), **8** for $\pm 9,999$ with INFINITY FAMILY BEZEL AND ADAPTER

(2) Display Type & Meter Power - LCD

Select **0** for LED, 120 Vac (49/440 Hz) (BQ20 or BQ90), **1** for LCD, 120 Vac (49/440 Hz) (BQ21), **2** for LED, 240 Vac (49/440 Hz) (BQ22 or BQ92), **3** for LCD, 240 Vac (49/440 Hz) (BQ23), **4** for LED, 9-32 Vdc (isolated) (BQ24 or BQ94), **5** for LCD, 9-32 Vdc (isolated) (BQ25), **6** for LED, 5 Vdc** (BQ26 or BQ96), **7** for LCD, 5 Vdc** (BQ27), **8** for LED, 24 Vac (BQ28 or BQ98), **9** for LCD, 24 Vac (BQ29), **A** for LED, 26-56 Vdc (isolated) (BQ2A or BQ9A), **B** for LCD, 26-56 Vdc (isolated) (BQ2B)

(3) Analog Output Adders

Select **0** for ± 1 or ± 2 V recorder output, non-isolated. (standard), **1** for 0-5 Vdc, non-isolated (BA01) , **2** for 0-10 Vdc, non-isolated (BA01) , **3** for 0-1 mA, source or sink, non-isolated (BA01) , **4** for 4-20 mA, source or sink, non-isolated (BA01) , **5** for 4-20 mA, sink (high-compliance), non-isolated. (BA02), **6** for 4-20 mA, ISOLATED (BA03)

(4) Control Output Adders

Select **0** for None, **1** for Dual-setpoint 10 A relay. (BDT1), **2** for Proportional 4-20 mA control, source or sink (BDP1), **3** for Time-proportional solid-state 2 A relay plus proportional 4-20 mA control, source or sink. (BDP2) , **4** for BCD (isolated, latched, buffered, byte addressable). Includes 50-pin mass-termination connector. (BDD2) , **5** for Single-setpoint 10 A relay (BDS1)

(5) Signal Conditioning Input Adders

Select **AVR1** for DC Voltage ± 199.9 mV (Q2000/Q3000) or ± 99.99 mV (Q8000/Q9000), **AVR2** for DC Voltage ± 1.999 V (Q2000/Q3000) or ± 999.9 mV (Q8000/Q9000), **AVR3** for DC Voltage ± 19.99 V (Q2000/Q3000) or ± 9.999 V (Q8000/Q9000), **AVR4** for DC Voltage ± 199.9 V (Q2000/Q3000) or ± 99.99 V (Q8000/Q9000), **BCR1** for DC Current ± 19.99 μ A (Q2000/Q3000) or ± 9.999 μ A (Q8000/Q9000), **BCR2** for DC Current ± 199.9 μ A (Q2000/Q3000) or ± 99.99 μ A (Q8000/Q9000), **BCR3** for DC Current ± 1.999 mA (Q2000/Q3000) or ± 999.9 μ A (Q8000/Q9000), **BCR4** for DC Current ± 19.99 mA (Q2000/Q3000) or ± 9.999 mA (Q8000/Q9000), **BCR5** for DC Current ± 199.9 mA (Q2000/Q3000) or ± 99.99 mA (Q8000/Q9000), **BCR6** for DC Current ± 1.999 A (Q2000/Q3000) or ± 999.9 mA (Q8000/Q9000), **CVR2** for AC AVG Voltage 199.9 mV (Q2000/Q3000) or 99.99 mV (Q8000/Q9000), **CVR3** for AC AVG Voltage 1.999 V (Q2000/Q3000) or 999.9 mV (Q8000/Q9000), **CVR4** for AC AVG Voltage 19.99 V (Q2000/Q3000) or 9.999 V (Q8000/Q9000), **CVR5** for AC AVG Voltage 199.9 V (Q2000/Q3000) or 99.99 V (Q8000/Q9000), **CVR6** for AC AVG Voltage 650 V (Q2000/Q3000) or 650.0 V (Q8000/Q9000), **DCR1** for AC AVG Current 19.99 μ A (Q2000/Q3000) or 9.999 μ A (Q8000/Q9000), **DCR2** for AC AVG Current 199.9 μ A (Q2000/Q3000) or 99.99 μ A (Q8000/Q9000), **DCR3** for AC AVG Current 1.999 mA (Q2000/Q3000) or 999.9 μ A (Q8000/Q9000), **DCR4** for AC AVG Current 19.99 mA (Q2000/Q3000) or 9.999 mA (Q8000/Q9000), **DCR5** for AC AVG Current 199.9 mA (Q2000/Q3000) or 99.99 mA (Q8000/Q9000), **DCR6** for AC AVG Current 1.999 A (Q2000/Q3000) or 999.9 mA (Q8000/Q9000), **DCR7** for 5 Amp Current transformer- 5 A = 199.9 A (Q2000/Q3000) or 5 A = 99.99 A (Q8000/Q9000), **FVR2** for True-RMS Voltage 199.9 mV (Q2000/Q3000) or 99.99 mV (Q8000/Q9000), **FVR3** for True-RMS Voltage 1.999 V (Q2000/Q3000) or 999.9 mV (Q8000/Q9000), **FVR4** for True-RMS Voltage 19.99 V (Q2000/Q3000) or 9.999 V (Q8000/Q9000), **FVR5** for True-RMS Voltage 199.9 V (Q2000/Q3000) or 99.99 V (Q8000/Q9000), **FVR6** for True-RMS Voltage 650 V (Q2000/Q3000) or 650 V (Q8000/Q9000), **GCR1** for True-RMS Current 19.99 μ A (Q2000/Q3000) or 9.999 μ A (Q8000/Q9000), **GCR2** for True-RMS Current 199.9 μ A (Q2000/Q3000) or 99.99 μ A (Q8000/Q9000), **GCR3** for True-RMS Current 1.999 mA (Q2000/Q3000) or 999.9 μ A (Q8000/Q9000), **GCR4** for True-RMS Current 19.99 mA (Q2000/Q3000) or 9.999 mA (Q8000/Q9000), **GCR5** for True-RMS Current 199.9 mA (Q2000/Q3000) or 99.99 mA (Q8000/Q9000), **GCR6** for True-RMS Current 1.999 A (Q2000/Q3000) or 999.9 mA (Q8000/Q9000), **GCR 7** for 5 Amp Current transformer 5 A = 199.9 A (Q2000/Q3000) or Default calibration 5 A=99.99 A (Q8000/Q9000), **H** for Frequency/rate input - Default calibration 100mV Hysteresis 1000 Hz = 1000 (Q2000/Q3000) or 1000 Hz = 0-9999 (Q8000/Q9000) (BSCH1), **JDC1** for Thermocouple input types J, K, and T -40 to +760°C (Q2000/Q3000) or -40.0 to +760.0°C (Q8000/Q9000) (BSCJ), **JDF1** for Thermocouple input types J, K, and T -40 to +1400°F (Q2000/Q3000) or -40.0 to +999.9°F (Q8000/Q9000) (BSCJ), **KDC1** for Thermocouple input types J, K, and T -40 to +1260°F (Q2000/Q3000) or -40.0 to +999.9°C (Q8000/Q9000) (BSCK), **KDF1** for Thermocouple input types J, K, and T -40 to +1999 °F (Q2000/Q3000) or -40.0 to +999.9°F (Q8000/Q9000) (BSCK), **TDC1** for Thermocouple input types J, K, and T -184 to 371°C (Q2000/Q3000) or -184.0 to +371.0° C (Q8000/Q9000) (BSCT), **TDF1** for Thermocouple input types J, K, and T -300 to 700°F (Q2000/Q3000) or -300.0 to +700.0° F (Q8000/Q9000) (BSCT), **MDC1** for RTD (Pt 100) input (BSCM) -200 to +830°C (Q2000/Q3000) or -200.0 to +830.0°C (Q8000/Q9000) (BSCM), **MDF1** for RTD (Pt 100) input (BSCM) -328 to +1526°F (Q2000/Q3000) or -328.0 to +999.9°F (Q8000/Q9000) (BSCM), **RDC1** for RTD (Pt 100) input (BSCM) -199.9 to

199.9°C (Q2000/Q3000), Not Recommended for Q8000/Q9000 (BSCR), **RDF1** for RTD (Pt 100) input (BSCM) -199.9 to 199.9°F (Q2000/Q3000), Not Recommended for Q8000/Q9000 (BSCR), **NPR1** for 3-wire ratio potentiometer input (BSCA) 1000 = 1 kOhm (Q2000/Q3000) or 9999 = 1 kOhm (Q8000/Q9000), **NPR2** for 3-wire ratio potentiometer input (BSCA) 1000 = 5 kOhm (Q2000/Q3000) or 9999 = 5 kOhm (Q8000/Q9000), **OOR1** for 2- or 4-wire resistance input (BSCR) - 19.99 ohm (Q2000/Q3000), Not Recommended for Q8000/Q9000 (BSCR), **OOR2** for 2- or 4-wire resistance input (BSCR) -199.9 ohm (Q2000/Q3000), Not Recommended for Q8000/Q9000 (BSCR), **OOR3** for 2- or 4-wire resistance input (BSCR) 1999 ohm (Q2000/Q3000), Not Recommended for Q8000/Q9000 (BSCR), **OOR4** for 2- or 4-wire resistance input (BSCR) 19.99 kOhm (Q2000/Q3000), Not Recommended for Q8000/Q9000 (BSCR), **P** for Process Signal Input, **E** for Process Signal Input plus Excitation Output, **S** for Strain-gage/microvolt input plus excitation

(6) Display Color

Select **Nothing(leave field blank)** for Red Display (standard), **,G** for Green Display

(7) Lens

Select **Nothing(leave field blank)** for Standard Lens (with Newport logo), **,BL** for Blank Lens

NOTE: All combinations may not be valid, check spec sheet for valid part numbers.

newportUS.com

[HOME](#) [PRODUCTS](#) [ON-LINE STORE](#) [QUOTES](#) [PRICELIST](#) [MANUALS](#) [SITEMAP](#) [SEARCH](#) [E-MAIL](#)

714-540-4914

Copyright 2001, NEWPORT Electronics, Inc. All rights reserved.

1/8 DIN (1A) CASE

Used with QUANTA, 203A, 204B, 267B, 268, 269, 872A, 2003B, 2004B, 6130A

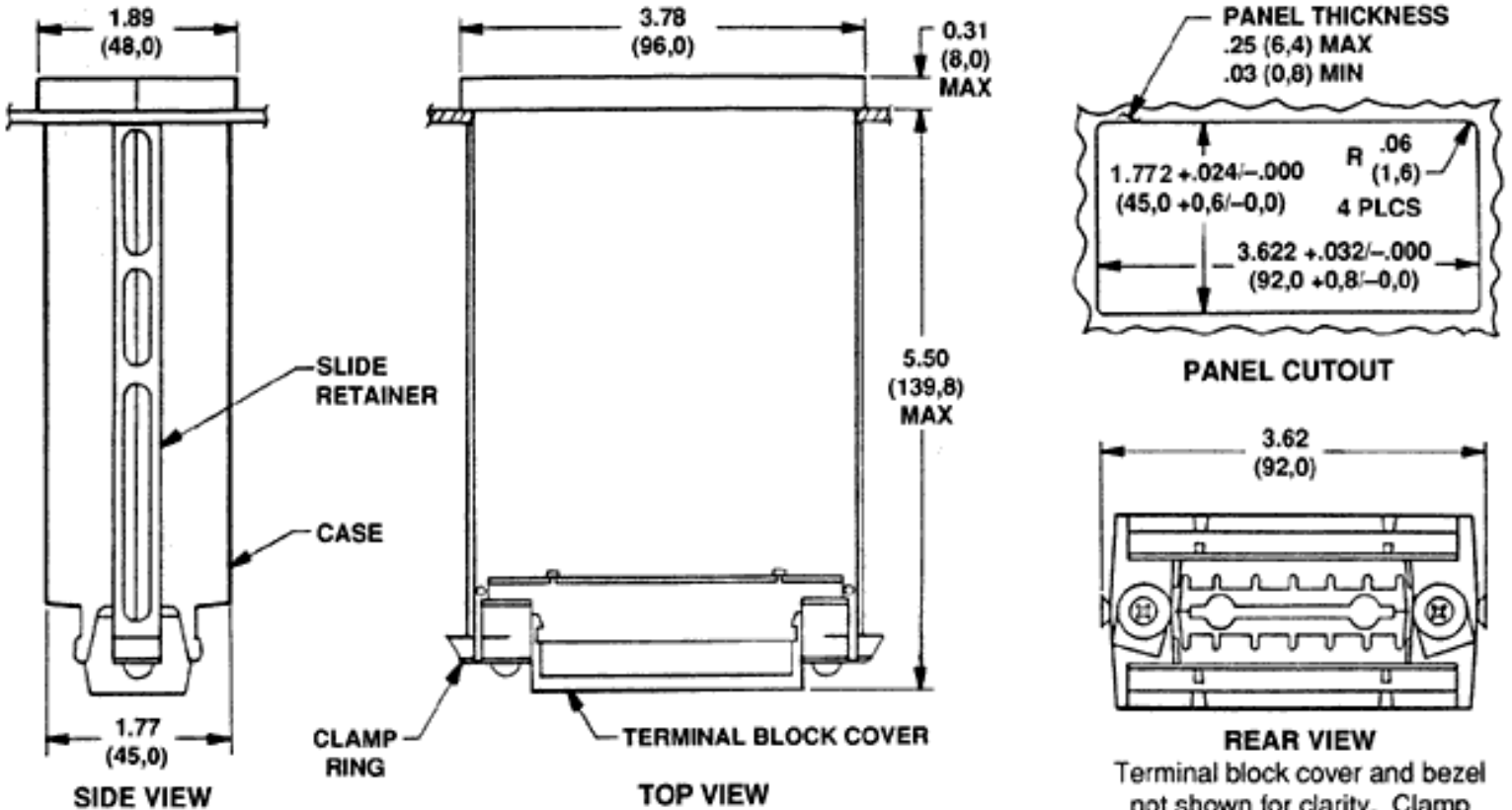

Note: Dimensions are in inches ± 0.01 "
with millimeters in () $\pm 0,25$ mm.

1/8 DIN (1A) CASE. Used with QUANTA, 203A, 204B, 267B, 268, 269, 872A, 2003B, 2004, 6130A.

1/8 DIN (2A) CASE

Used with 201A, 202A, 2001A, 2002A, 6152A, 6161A, 6162A, 6163A

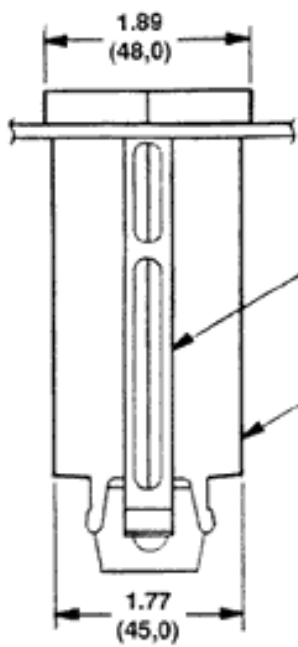

SIDE VIEW

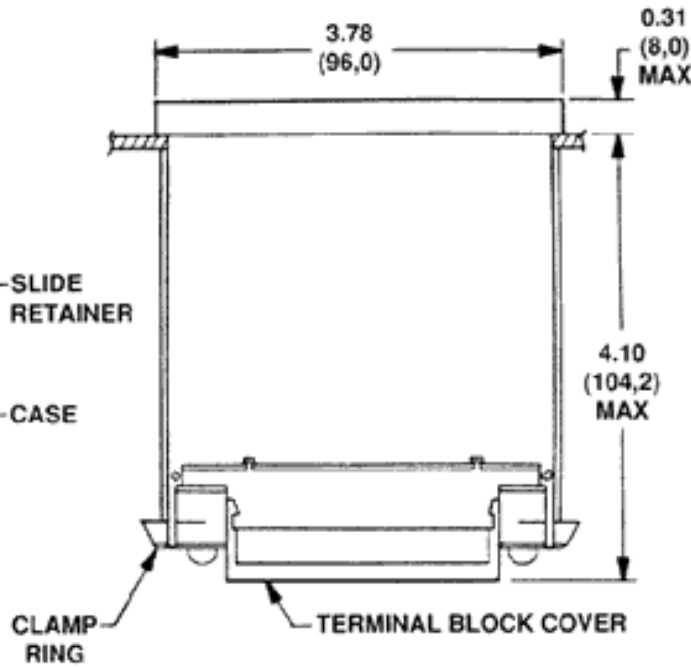

TOP VIEW

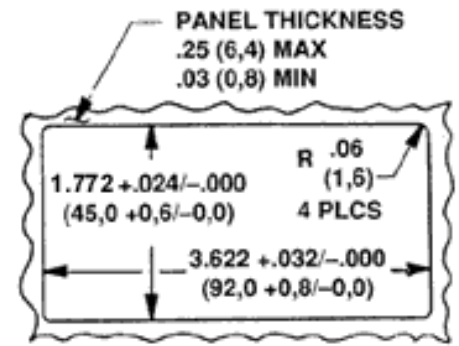

PANEL CUTOUT

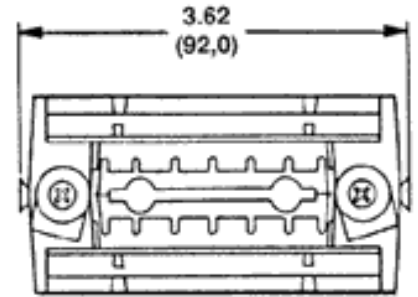

REAR VIEW

Terminal block cover and bezel not shown for clarity. Clamp rings rotated and slide retainers removed as shown for installation.

Note: Dimensions are in inches ± 0.01 " with millimeters in () ± 0.25 mm.

1/8 DIN (2A) CASE. Used with 201A, 202A, 2001A, 2002B, 6152A, 6161A, 6162A, 6163A.

newportUS.com

1-800-6387678®

1-800-NEWPORT

HOME PRODUCTS ON-LINE STORE QUOTES PRICELIST MANUALS SITEMAP SEARCH E-MAIL

714-540-4914

Copyright 2003, NEWPORT Electronics, Inc. All rights reserved.

QUANTA

D4

QUANTA

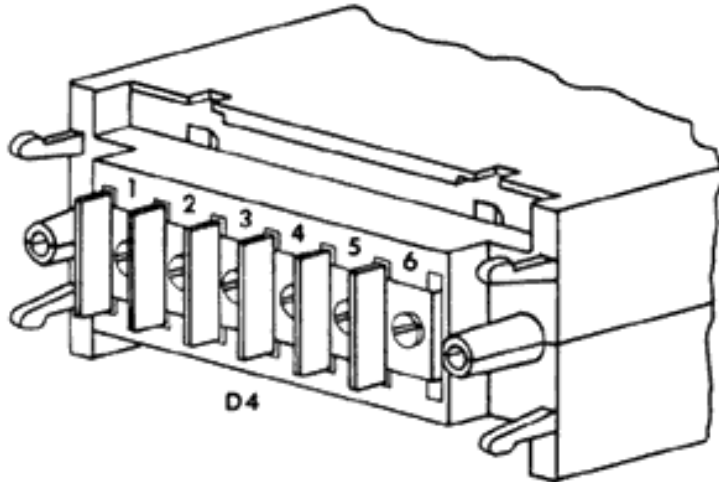

Q2000H & Q9000H

D4

AC POWER VERSIONS

1	AC PWR HI
2	AC PWR LO
3	AC PWR GND
4	SIG HI (AC COUPLED)
5	SIG LO
6	SIG HI (DC COUPLED)

DC POWER VERSIONS

1	N/C
2	+DC PWR
3	DC PWR RTN
4	SIG HI (AC COUPLED)
5	SIG LO
6	SIG HI (DC COUPLED)

Q2000 J, K, T & Q9000 J, K, T

D4

AC POWER VERSIONS

1	AC HI
2	AC LO
3	AC GND
4	ANALOG GND
5	SIG LO (TC -)
6	SIG HI (TC +)

DC POWER VERSIONS

1	N/C
2	+DC PWR
3	DC PWR RTN
4	ANALOG GND
5	SIG LO (TC -)
6	SIG HI (TC +)

Q2000A/B & Q9000A/B

D4

AC POWER VERSIONS

1	AC HI
2	AC LO
3	AC GND
4	ANA GND
5	SIG LO
6	SIG HI

DC POWER VERSIONS

1	N/C
2	+DC PWR
3	DC PWR RTN
4	ANA GND
5	SIG LO
6	SIG HI

Q2000N & Q9000N

D4

AC POWER VERSIONS

1	AC HI
2	AC LO
3	AC GND
4	SIG LO
5	+REF
6	SIG HI

DC POWER VERSIONS

1	N/C
2	+DC PWR
3	DC PWR RTN
4	SIG LO
5	+REF
6	SIG HI

Q2000 C, D, F, G & Q9000 C, D, F, G

D4

AC POWER VERSIONS

1	AC PWR HI
2	AC PWR LO
3	AC PWR GND
4	AC & DC *
5	AC SIG LO
6	AC SIG HI

DC POWER VERSIONS

1	N/C
2	+DC PWR
3	DC PWR RTN
4	AC & DC *
5	AC SIG LO
6	AC SIG HI

Q2000P

D4

AC POWER VERSIONS

1	AC HI
2	AC LO
3	AC GND
4	N/C
5	SIG LO
6	SIG HI

DC POWER VERSIONS

1	N/C
2	+DC PWR
3	DC PWR RTN
4	N/C
5	SIG LO
6	SIG HI

* No connection (N/C) on Q2000C/D and Q9000C/D.

Q2000E & Q9000E

D4

AC POWER VERSIONS

1	AC HI
2	AC LO
3	AC GND
4	+ EXC
5	SIG LO/-EXC
6	SIG HI

DC POWER VERSIONS

1	N/C
2	+DC PWR
3	DC PWR RTN
4	+ EXC
5	SIG LO/-EXC
6	SIG HI

Q9000P

D4

AC POWER VERSIONS

1	AC HI
2	AC LO
3	AC GND
4	N/C
5	SIG LO
6	SIG HI

DC POWER VERSIONS

1	N/C
2	+DC PWR
3	DC PWR RTN
4	N/C
5	SIG LO
6	SIG HI



[NEXT](#)