

RODLESS CYLINDER WITH BALL RECIRCULATING GUIDE



The range of rodless cylinders with ball circulation guides is available with five different bores \varnothing 16, 25, 32, 40 and 63. The bore 63 can be supplied in two versions: the "standard" one for intermediate loads and the "heavy" one for considerably weighty loads. Besides the general features specified for standard rodless cylinders, the other main features are:

- Very high load capacity, acting in all directions without discharging onto the cylinder slide.
- Hardened steel guide connected firmly to the cylinder barrel.
- Ball circulation pads constructed using special technology that make them very silent when the guide slides, with very long maintenance intervals. For example, they only need lubricating every 2000 km or once a year, using type 2 grease, preferably containing lithium soap.
- Extra sturdy slide support with various holes for fixing the loads. Holes for centring pins are also provided.
- 100 to 2650 stroke at intervals of 1 mm.
- Integrated pneumatic adjustable cushioning.
- Adjustable limit switches and decelerations can be applied at any time.

For this type of cylinder (size 32 and upwards), the valves can be fitted directly using the retracting sensors without requiring any intermediate brackets. Refer to the table on page A1.48

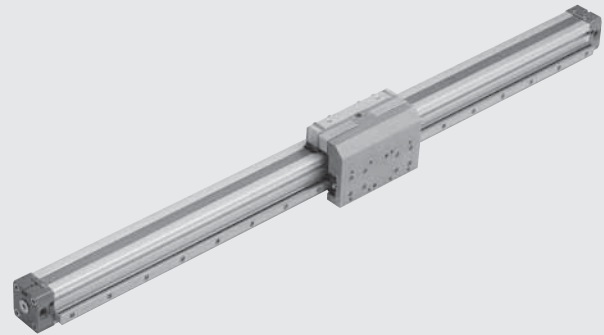

TECHNICAL DATA		NBR	FKM/FPM
Operating pressure	bar		1 to 8
	MPa		0.1 to 0.8
	Psi		14.5 to 116
Temperature range	$^{\circ}$ C		-10 to +80
	$^{\circ}$ F		14 to 176
Fluid		50 μ m unlubricated filtered air lubrication, if used, must be continuous	
Bores	mm	\varnothing 16, 25, 32, 40, 63	
Type of construction		Doubl-acting rodless cylinder with direct transmission system	
Strokes	mm	\varnothing 16: from 100 to 1350 with 1 interval	
		\varnothing 25: from 100 to 2300 with 1 interval	
		\varnothing 32: from 100 to 2300 with 1 interval	
		\varnothing 40: from 100 to 2250 with 1 interval	
		\varnothing 63 standard: from 100 to 2100 with 1 interval	
Threaded ports	Assembly	\varnothing 63 heavy: from 100 to 2650 with 1 interval	
		M5, G1/8", G1/4", G3/8"	
Recommended speed	m/s	<1	\geq 1
Max. speed with decelerators	m/s	<1	2
Weight		See cylinder "General technical data" at the beginning of the chapter	
Notes		For speeds lower than 0.2 m/s to prevent surging, use the version No stick-slip	

COMPONENTS

For version 275

- ① CYLINDER: see components of rodless cylinders - series STD
- ② GUIDE: hardened steel
- ③ PAD: steel with hardened ball circulation
- ④ SLIDE SUPPORT: anodised aluminium

For version 276

Besides the details specified above:

- ⑤ END-OF-STROKE STUD PIN: zinc-plated steel, complete with 2 zinc-plated nuts for fixing
- ⑥ DECELERATOR: burnished steel, complete with 2 zinc-plated or burnished nuts for fixing
- ⑦ DECELERATOR SUPPORT: anodised aluminium
- ⑧ BRACKET: hardened-and-tempered and zinc-plated steel

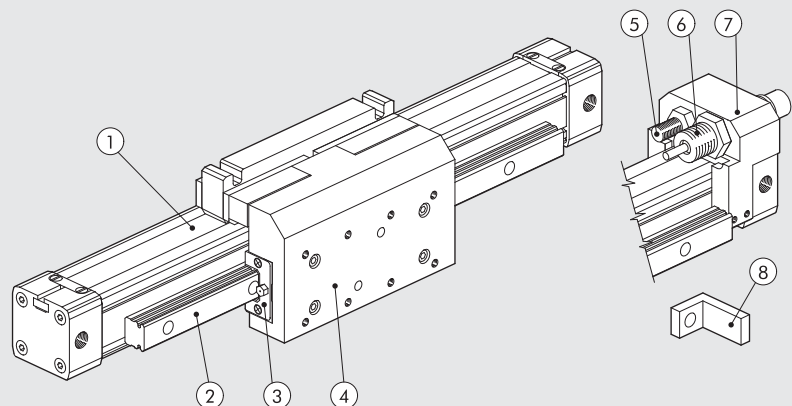

DIMENSIONING - FORCES AND MOMENTS

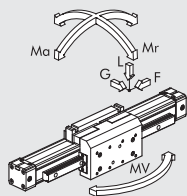
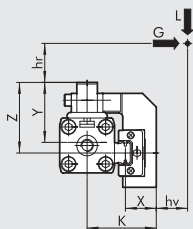

Ø	Version	Actual force F at 6 bar [N]	Cushioning stroke [mm]	K [mm]	X [mm]	Y [mm]	Z [mm]	Max load L [N]	Max load G [N]	Ma max [Nm]	Mr max [Nm]	Mv max [Nm]
16	-	110	15	35	16	29	33	500	500	16	15	16
25	-	250	21	50.5	21	44	51.5	1500	1500	100	50	100
32	-	420	26	59	22.5	53.5	70	3000	3000	200	100	200
40	-	640	32	68	24.7	58	73	4000	4000	200	140	200
63	standard	1550	40	84	23.1	79	100	6000	6000	400	140	400
63	heavy	1550	40	91	29.2	79	88	10000	10000	600	400	600

N.B.: When the cylinder is subjected simultaneously to torque and force, keep to the following equations, where the lengths have to be given in metres.

$$Ma = F \times (hr + Y) \quad Mr = G \times (hr + z) + Lx (hv + X) \quad Mv = F \times (K + hv)$$

$$\frac{Ma}{Ma_{max}} + \frac{Mr}{Mr_{max}} + \frac{Mv}{Mv_{max}} + \frac{L}{L_{max}} + \frac{G}{G_{max}} \leq 1$$

DIAGRAM OF SPEED AND MAXIMUM CUSHIONABLE LOAD

For the cylinder to reach the end-of-stroke position without intense or repeated impact which would damage it, it is necessary to annul the kinetic energy of the moving mass and the work generated. The maximum cushionable load depends on the traversing speed and the absorption of the air buffer supplied standard with the various cylinders. The diagram shows the speeds and cushionable mass for the various diameters at a pressure of 6 bar.

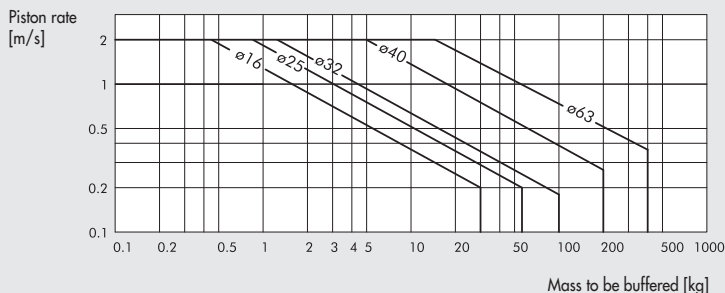

MAXIMUM LOAD ACCORDING TO THE DISTANCE BETWEEN SUPPORTS

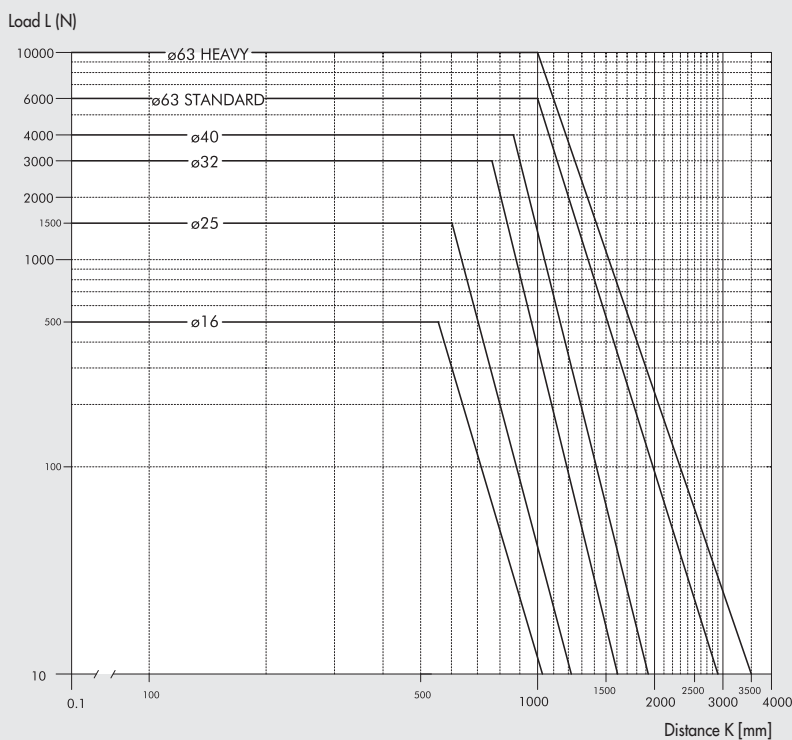
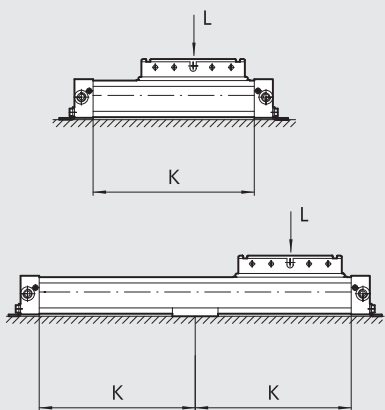

DIMENSIONS Ø 63

HEAVY

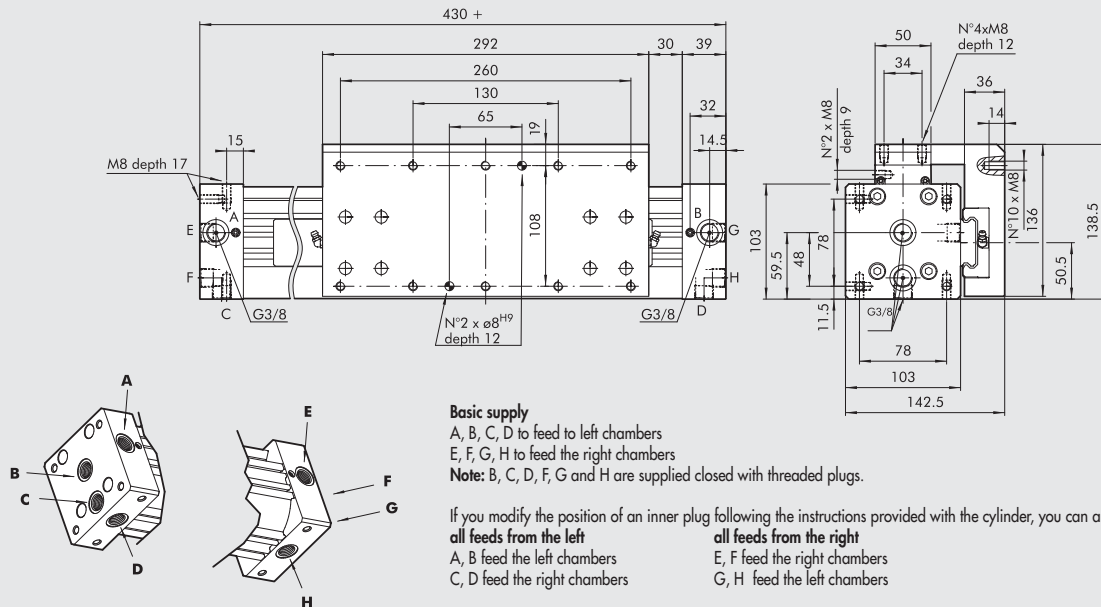

STANDARD

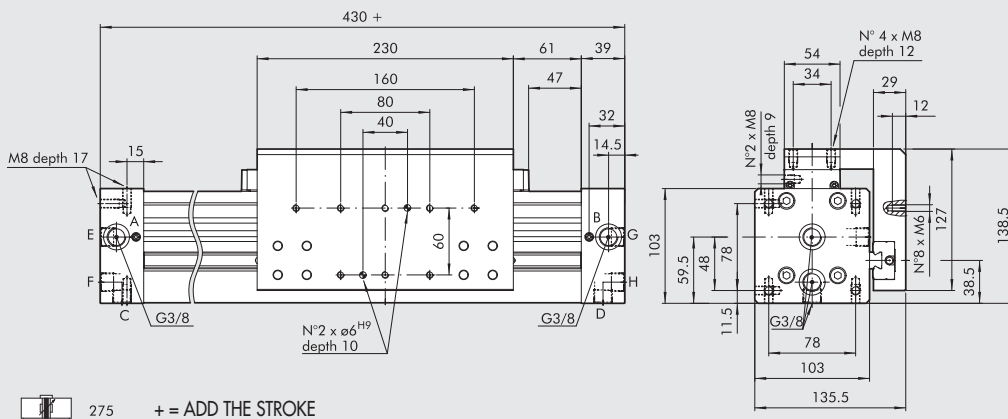

ASSEMBLY DIAGRAMS

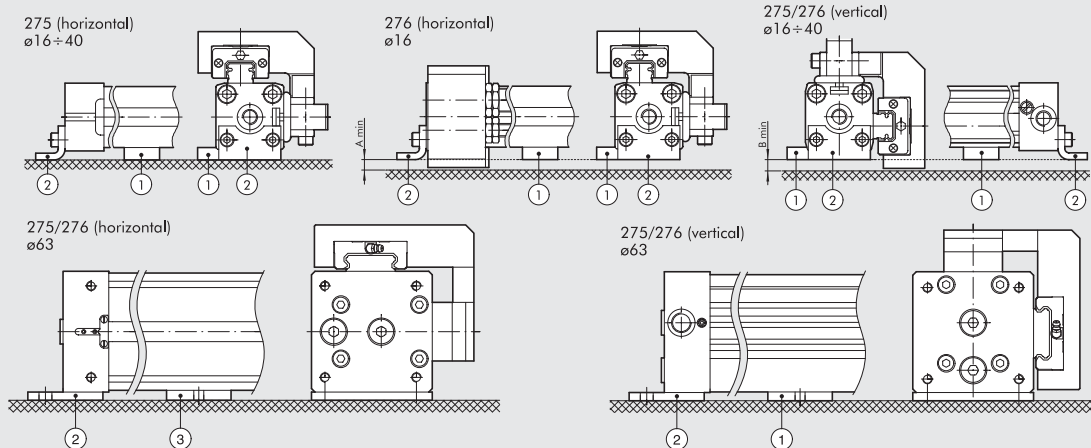

Ø	Horizontal layout		Vertical layout	
	A min	Intern. support code (1)	B min	Intern. support code (1)
16	8	W0950164004	12	W0950164004
25	10	W0950254004	10	W0950254004
32	4	W0950324004	11	W0950324004
40	3	W0950404004	5	W0950404004
63	-	W0950637032	-	W0950637036

DIMENSION VERSION WITH ADJUSTABLE LIMIT SWITCH AND SHOCK ABSORBERS Ø 16 to 63

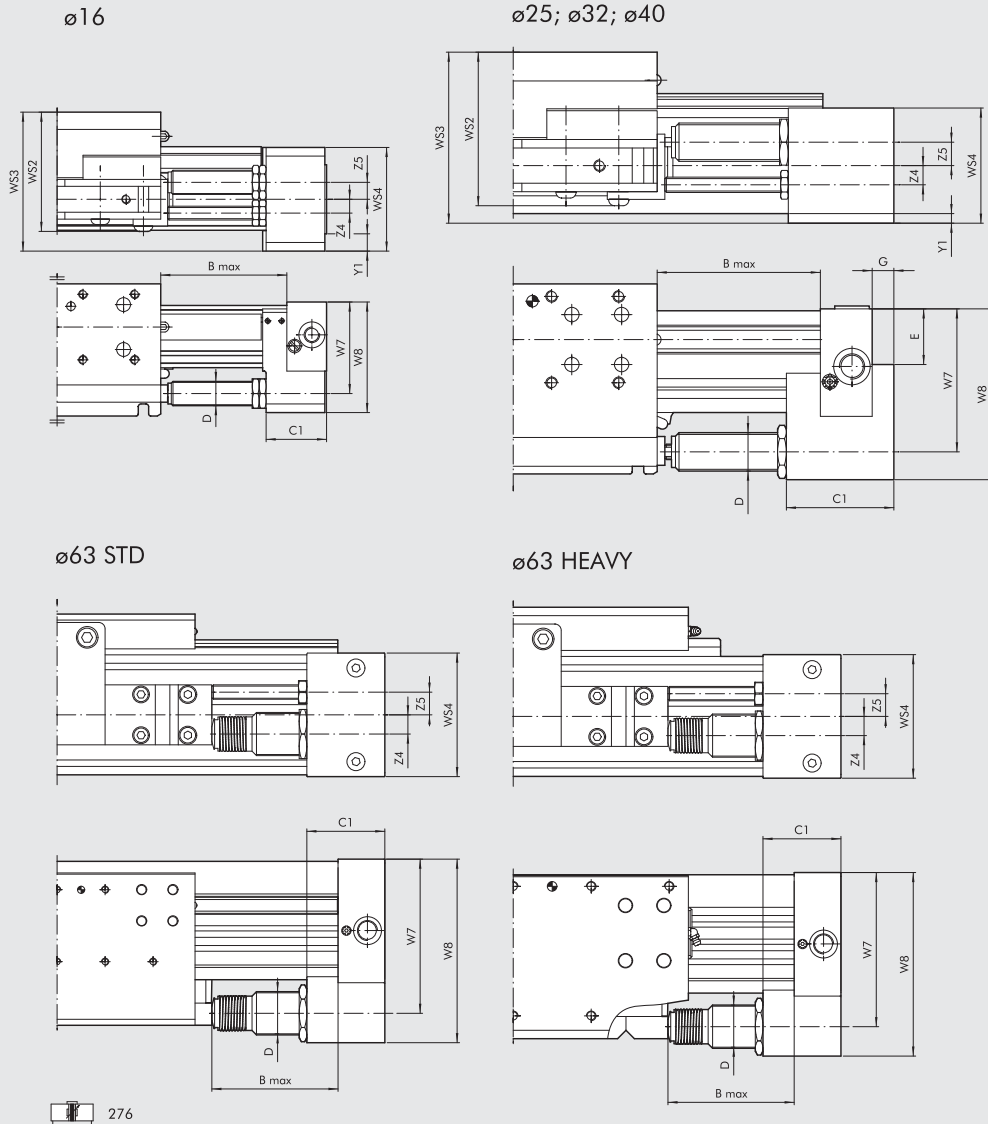

Ø	Version	B max	C1	D	E	G	W7	W8	WS2	WS3	WS4	Y1	Z4	Z5	Stroke	Max. cushioned force		Max. impact force [N]	Max. thrust force [N]
																Per stroke [J]	Per hour [J]		
16	-	50	22	M12x1	-	-	38	46	52	56	42	7.5	7	7.5	10.4	10	14125	1000	220
25	-	72	44	M14x1.5	17	9	53	67	71	80.5	50	5	8	9.8	16	26	34000	2800	530
32	-	90	56	M20x1.5	29	11	74	89	82.5	91	60	4	10	12.2	22	54	53700	3750	890
40	-	105	74	M25x1.5	32.8	14	89	108	92	108	75	1.5	12.5	12.7	25	90	70000	5500	1550
63	standard	105	65	M36x1.5	-	-	128.5	153	-	-	103	-	16	19	25	160	91000	11120	2220
63	heavy	105	65	M36x1.5	-	-	128.5	153	-	-	103	-	16	19	25	160	91000	11120	2220

For graphs to help choose shock absorbers see page A1.151

KEY TO CODES

CYL	2 7 TYPE	5	0	2 5 BORE	0 1 5 0 STROKE	C	N GASKETS
	27 Rodless cylinder	5 Double-acting cushioned magnetic with ball circulation guides 6 Double-acting cushioned magnetic with ball circulation guides + adjustable limit switch and shock absorbers	0 STD Magnetic S STD Non-magnetic ■ G STD No stick-slip A HEAVY Magnetic ■ B HEAVY No stick-slip C HEAVY Non-magnetic	16 25 32 40 63	Ø 16: 100 to 1350 mm Ø 25 - 32: 100 to 2300 mm Ø 40: 100 to 2250 mm Ø 63 std: 100 to 2100 mm Ø 63 heavy: 100 to 2650 mm		N NBR gasket ● V FKM/FPM gasket

■ For speeds lower than 0.2 m/s, to prevent surging. Use no-lubricated air only ● For speed ≥ 1/m/s

RODLESS CYLINDER SERIES DOUBLE

ACTUATORS

RODLESS CYLINDER - SERIES DOUBLE

DIMENSIONING - FORCES AND MOMENTS

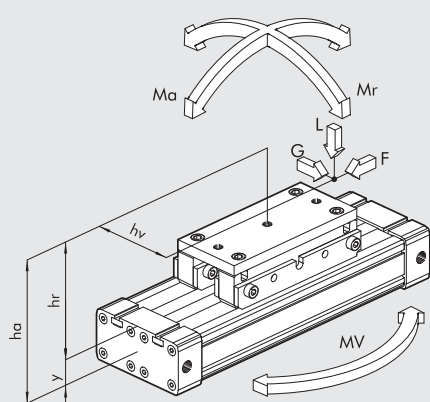

Bore Ø	Actual force F at 6 bar [N]	Cushioning stroke [mm]	Max load L [N]	Ma max [Nm]	Mr max [Nm]	Mv max [Nm]
2x16	200	15	240	8	2.4	1
2x25	480	21	600	30	8	6
2x32	820	26	900	60	16.5	10

N.B.: When the cylinder is subjected simultaneously to torque and force, keep to the following equations, where the lengths have to be given in metres.

$$Ma = F \times ha \quad Mr = L \times hv + G \times hr \quad Mv = F \times hv$$

$$\frac{Mv}{Mv_{max}} \leq 1; \quad \frac{L}{L_{max}} \leq 1; \quad \frac{Ma}{Ma_{max}} + \frac{Mr}{Mr_{max}} + 0.22 \times \frac{Mv}{Mv_{max}} + 0.4 \times \frac{L}{L_{max}} \leq 1$$

For technical data, see **rodless cylinders - series STD**.

For weights, see cylinder **"General technical data"** at the beginning of the chapter.

DIMENSIONS OF RODLESS CYLINDER, DOUBLE SERIES

+ = ADD THE STROKE

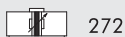
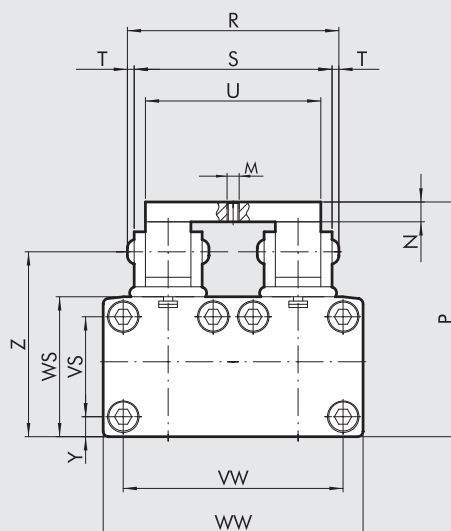
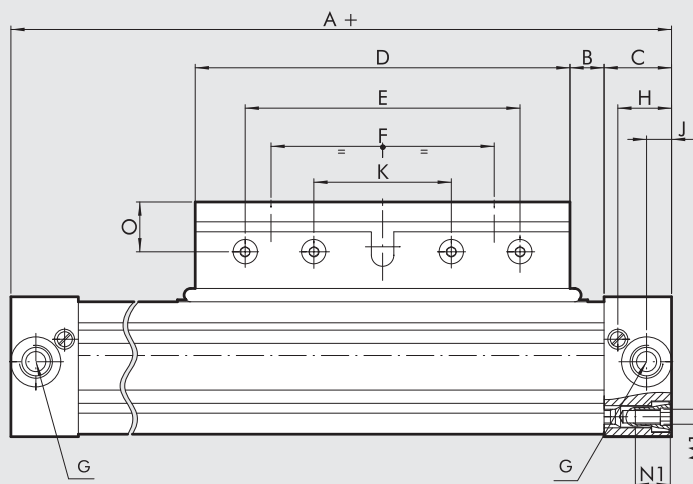

Ø	A	B	C	D	E	F	G	H	J	K	M	N	M1	N1	O	P	R	S	T	U	VW	VS	WW	WS	Y	Z
2x16	130	12	15	76	64	48	M5	12	6.4	32	M5	10	M3	7	16	53.5	48	42	3	34	42	18	51	27	4.5	37.5
2x25	200	17	23	120	100	80	1/8	18.5	8.5	50	M6	15	M5	12	20	74	66	59	3.5	50	63	27	72	41	7	53.5
2x32	250	23	27	150	110	90	1/4	22.5	10.5	55	M6	12	M6	14	20	95	86.5	77.5	4.5	70	86	40	100	56	8	74

DIAGRAM OF SPEED AND MAXIMUM CUSHIONABLE LOAD

For the cylinder to reach the end-of-stroke position without intense or repeated impact which would damage it, it is necessary to annul the kinetic energy of the moving mass and the work generated.

The maximum cushionable load depends on the traversing speed and the absorption of the air buffer supplied standard with the various cylinders. The diagram shows the speeds and cushionable mass for the various diameters at a pressure of 6 bar.

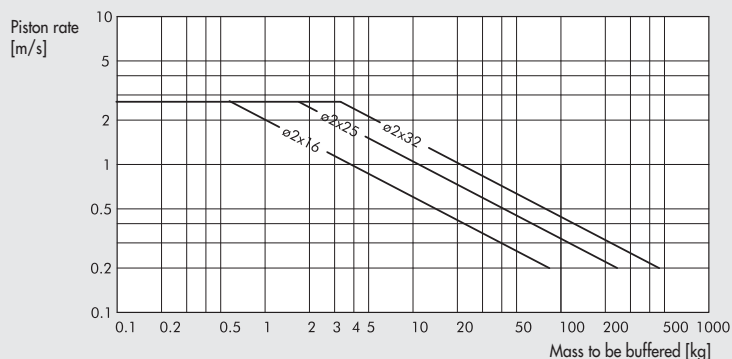

ACCESSORIES AND SPARE PARTS FOR RODLESS CYLINDERS

FIXINGS FOR RODLESS STD, "V" GUIDE, WITH BALL RECIRCULATING GUIDE CYLINDERS

FOOT Ø 16; 25

+ = ADDED STROKE

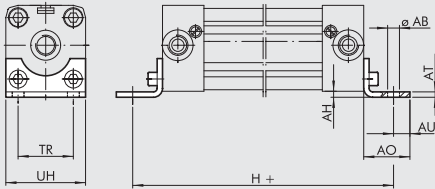

Code	Ø	ØAB	AH	AO	AT	AU	TR	UH	H	Weight [g]
W0950167001	16	3.6	1.5	14	1.6	4	18	26	150	10
W0950257001	25	5.5	2	22	2.5	6	27	40	232	32

Note: Individually packed with 2 screws

FOOT Ø 32; 40

+ = ADDED STROKE

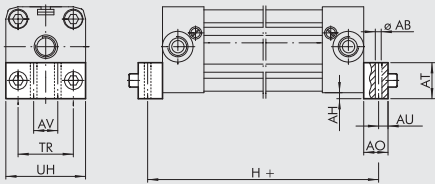

Code	Ø	ØAB	AH	AO	AT	AU	AV	TR	UH	H	Weight [g]
W0950327001	32	6.6	4	25	20	8	20	36	51	284	88
W0950407001	40	9	2	25	20	11.5	30	54	71	327	112

Note: Individually packed with 2 screws

FOOT Ø 63

+ = ADDED STROKE

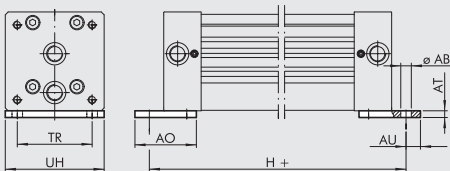

Code	Ø	ØAB	AT	AO	AU	TR	UH	H	Weight [g]
W0950637001	63	11	7	64	15	78	103	460	360

Note: Individually packed with 2 screws

INTERMEDIATE FOOT Ø 16; 25 FOR STD AND "V" GUIDE

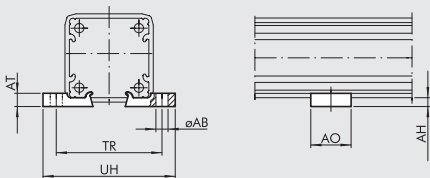

Code	Ø	ØAB	AH	AO	AT	TR	UH	Weight [g]
W0950167031	16	5.5	3	20	5	41	53	4
W0950257031	25	5.5	4	20	6	48	60	6
0950254094*	25	5.5	4	20	6	48	60	6

Note: Individually packed.
* For the "V" guide version only

INTERMEDIATE FOOT Ø 32; 40 FOR STD AND "V" GUIDE

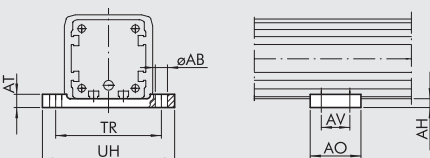

Code	Ø	ØAB	AH	AO	AT	AV	TR	UH	Weight [g]
W0950327032	32	6.5	5	55	8	40	61.5	73	72
W0950407032	40	6.5	7	60	8	45	70-75	85	104

Note: plate supplied complete with 4 screws, 4 fixing plates

INTERMEDIATE SUPPORT Ø 63 FOR VERSION STD, "V" GUIDE AND VERTICAL POSITION BALL RECIRCULATING

Code	Ø	ØAB	AH	AO	AT	TR	UH	Weight [g]
W0950637032	63	8.5	7.5	55	7.5	78	103	330

Note: plate supplied complete with 4 screws, 4 fixing plates

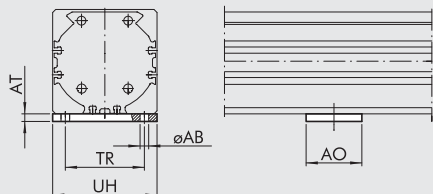

INTERMEDIATE SUPPORT Ø 16 to 25 FOR BALL RECIRCULATING

Code	Ø	ØAB	ØAB1	AH	AO	AV	TR	TR1	TR2	UH
W0950164004	16	3.5	M3	3	12	6	20	4	8	32.5
W0950254004	25	5.5	M5	4	20	10.5	30.5	6	12	49

Note: Supplied complete with 4 screws

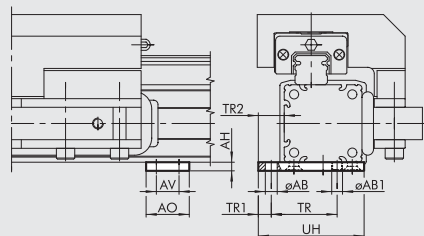

INTERMEDIATE SUPPORT Ø 32 to 40 FOR BALL RECIRCULATING

Code	Ø	ØAB	ØAB1	AH	AO	AT	AV	TR	TR1	TR2	UH
W0950324004	32	6.5	M6	5	55	5	40	55	6	13	66
W0950404004	40	6.5	M6	6.6	60	8	45	63	7.5	15	77

Note: Supplied complete with 4 screws, 4 plates.

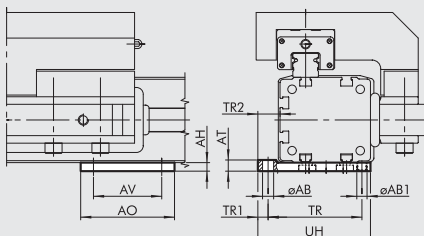

INTERMEDIATE SUPPORT KIT Ø 63 FOR HORIZONTAL POSITION BALL RECIRCULATING

Code	Ø	ØAB	AH	AO	AT	TR	UH
W0950637036	63	8.5	7.5	55	8.5	78	103

Note: Supplied complete with 4 screws, 4 plates.

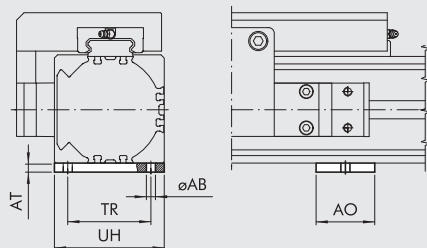

NOTES

FIXINGS FOR RODLESS CYLINDER SERIE DOUBLE

FOOT Ø 16; 25

+ = ADD STROKE

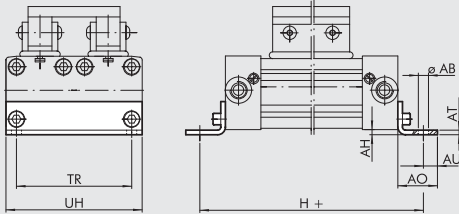

Code	Ø	ØAB	AH	AO	AT	AU	TR	UH	H	Weight [g]
W0950168001	2x16	3.6	1.5	14	1.6	4	42	51	150	18
W0950258001	2x25	5.5	2	22	2.5	6	63	72	232	54

Note: Individually packed complete with 2 screws

FOOT Ø 32

+ = ADD STROKE

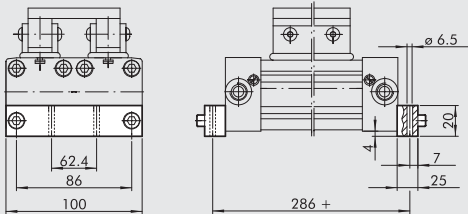

Code	Description	Weight [g]
W0950328036	Foot DOUBLE Ø 32	156

Note: Individually packed complete with 2 screws

VERTICAL FOOT Ø 16; 25

+ = ADD STROKE

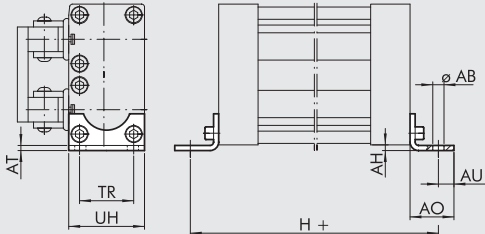

Code	Ø	ØAB	AH	AO	AT	AU	TR	UH	H	Weight [g]
W0950167001	2x16	3.6	1.5	14	1.6	4	18	26	150	10
W0950257001	2x25	5.5	4	22	2.5	6	27	40	232	32

Note: Individually packed complete with 2 screws

VERTICAL FOOT Ø 32

+ = ADD STROKE

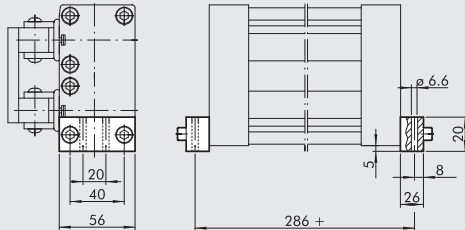

Code	Description	Weight [g]
W0950328035	Vertical foot Ø 32	92

Note: Individually packed complete with 2 screws

INTERMEDIATE FOOT Ø 16 to 32

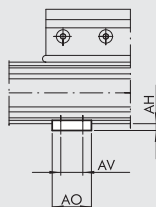
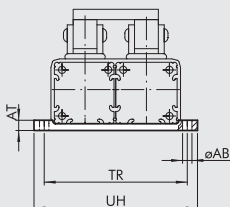

Code	Ø	ØAB	AH	AO	AT	AV	TR	UH	Weight [g]
W0950168037	2x16	3.5	3	12	6	6	60.5	64	16
W0950258037	2x25	5.5	4	20	6	10.5	84.5	96	34
W0950328037	2x32	6.5	5	55	8	40	111.5	123	96

Note: Supplied complete with 8 screws, 8 fixing plates (plates for Ø 32 only)

ACCESSORIES FOR CONVERTING STD RODLESS CYLINDERS INTO SWING CYLINDERS

KIT TO TRANSFORM INTO SWING VERSION

Ø16 to 40

Ø63

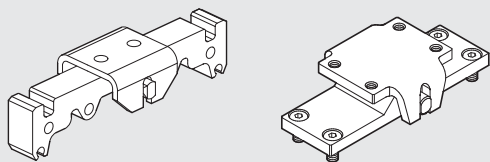

Code	Ø	Weight [g]
W0950167035	16	34
W0950257035	25	118
W0950327035	32	450
W0950327035	40	450
W0950637035	63	810

Note: Ø 16 to 40: Supplied complete with 1 adaptor, 1 support, 1 pin, 1 bushing
 Ø 63: Supplied complete with 1 plate, 1 support, 1 pin, 2 bushings, 4 screws

DRIVE PIN

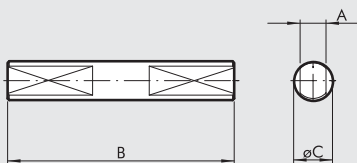

Code	Ø	A	B	ØC	Weight [g]
W0950167034	16	2.9	28	5	6
W0950257034	25	5	42	8	16
W0950327034	32	8	70	12	52
W0950327034	40	8	70	12	52
W0950637034	63	10	82	14	100

Note: Individually packed

SWING SUPPORT Ø 16; 25

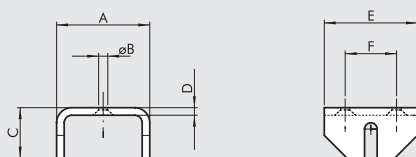

Code	Ø	A	ØB	C	D	E	F	Weight [g]
W0950167033	16	25	4.5	13	2	20	10	14
W0950257033	25	37	5.5	20	3	30	16	40

Note: Individually packed

SWING SUPPORT Ø 32; 40; 63

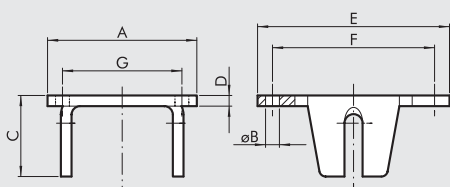

Code	Ø	A	ØB	C	D	E	F	G	Weight [g]
W0950327033	32	70	6.5	38	5	90	75	55	274
W0950327033	40	70	6.5	38	5	90	75	55	274
W0950637033	63	80	M8	32	8	80	65	37	400

Note: Individually packed

SENSOR MAGNETIC

RETRACTABLE SENSOR

SENSOR, SQUARE TYPE
 Latest generation,
 secure fixing

SENSOR, OVAL TYPE
 Traditional

For codes and technical data, see **chapter A6**.

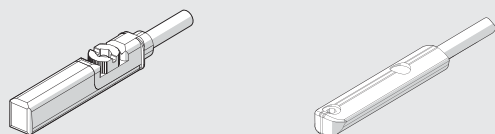

SENSOR SUPPORT Ø 16; 25

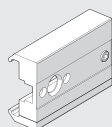

Code	Description
0950164001	Sensor support STD

Note: Supplied with 1 stud pin, 2 screws

SENSOR SUPPORT Ø 16 FOR RODLESS CYLINDER WITH BALL RECIRCULATING

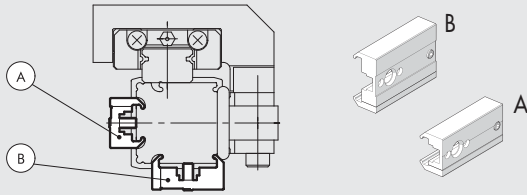

Code sensor support	Description sensor support	Type sensor support	Mounting on the carriage opposite side	Mounting on the guide opposite side
0950164003	Sensor support short	A	•	
0950164001	Sensor support std	B		•

Note: Supplied complete with 2 screws, 1 pin

SHOCK ABSORBERS

ADJUSTABLE LIMIT SWITCH AND SHOCK ABSORBERS KIT

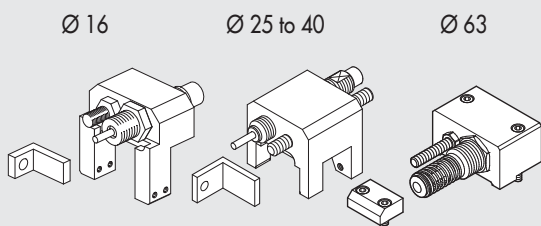

Code	Description	Weight [g]
0950164002	Rodless cylinder limit switch and shock absorbers Ø 16	125
0950254002	Rodless cylinder limit switch and shock absorbers Ø 25	260
0950324002	Rodless cylinder limit switch and shock absorbers Ø 32	460
0950404002	Rodless cylinder limit switch and shock absorbers Ø 40	730
0950634002	Rodless cylinder limit switch and shock absorbers Ø 63	1620

Note: Supplied complete with 1 shock absorber support, 1 standard shock absorber, 1 shock absorber nut, 1 limit switch grub screw, 1 grub screw nut (2 for Ø 63), 1 bracket, 1 bracket screw, 4 locking grub screws (for Ø 16 and Ø 25), 4 locking plates and 4 screws (for Ø 32 and Ø 40)

ADJUSTABLE LIMIT SWITCH AND SHOCK ABSORBERS KIT FOR RODLESS CYLINDER WITH "V" GUIDE

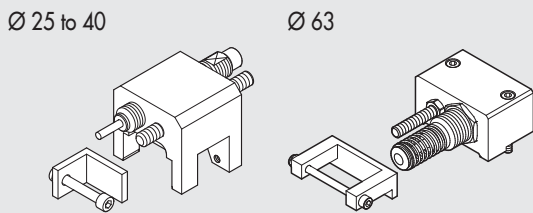

Code	Description	Weight [g]
0950254004	Rodless cylinder limit switch and shock absorbers Ø 25	260
0950324004	Rodless cylinder limit switch and shock absorbers Ø 32	460
0950404004	Rodless cylinder limit switch and shock absorbers Ø 40	730
0950634004	Rodless cylinder limit switch and shock absorbers Ø 63	1620

Note: Supplied complete with 1 shock absorber support, 1 standard shock absorber, 1 shock absorber nut, 1 limit switch grub screw, 1 grub screw nut (2 for Ø 63), 1 bracket, 1 bracket screw, 4 locking grub screws (for Ø 25), 4 locking plates and 4 screws (for Ø 32 and Ø 40)

SHOCK ABSORBERS

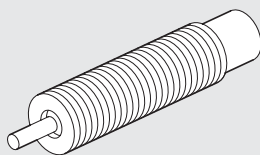

Code	Description	Ø
0950004003	Shock absorbers ECO15 MF1 + nut M12x1	16
0950004004	Shock absorbers ECO25 MC2 + nut M14x1.5	25
0950004005	Shock absorbers ECO50 MC2 + nut M20x1.5	32
0950004006	Shock absorbers ECO100 MF2 + nut M25x1.5	40
0950004007	Shock absorbers ECO125 MF3 + nut M36x1.5	63

GRAPHS TO HELP CHOOSE THE RIGHT SHOCK ABSORBERS

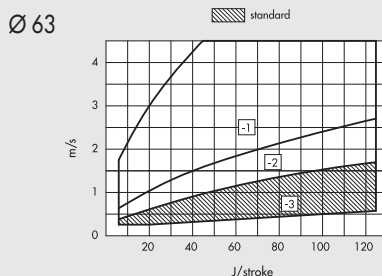
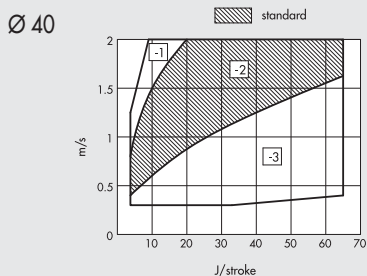
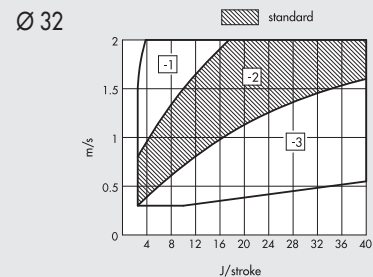
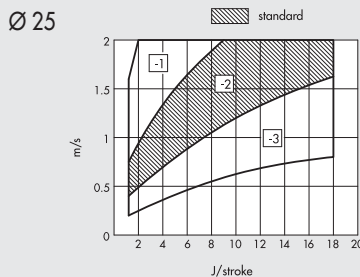
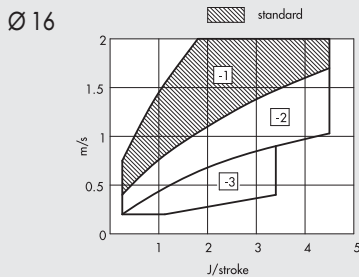

The dotted areas indicate that the SHOCK ABSORBERS is supplied standard. Other options can be selected depending on the speed [m/sec] and the maximum work force [J/stroke] to dissipate at each stroke. Refer to the diagrams above to select the correct option.

SPARE PARTS FOR STD RODLESS CYLINDERS, "V" GUIDE, BALL RECIRCULATING GUIDE, DOUBLE

ACTUATORS

ACCESSORIES AND SPARE PARTS FOR RODLESS CYLINDERS

"LAST RELEASE" CYLINDER

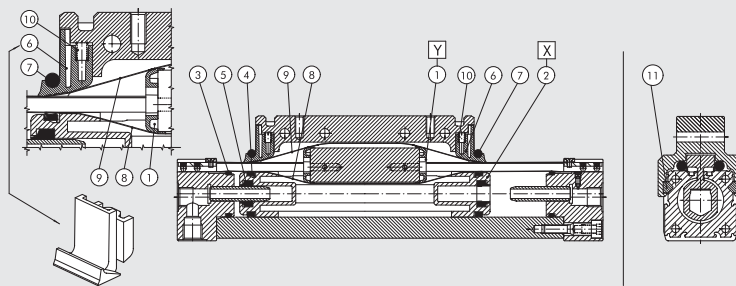
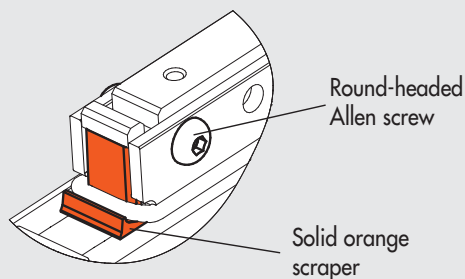

- ① Bands support Kit
- ② Piston kit
- ③ ④ ⑤ ⑥ ⑦ ⑩ NBR gaskets Kit (FKM/FPM for ⑦)
- ③ ④ ⑤ ⑥ ⑦ ⑩ FKM/FPM gaskets Kit
- ⑧ ⑨ Bands Kit (inner/outer)
- ⑪ "V" guide plate kit

Spare parts label
on one cylinder side

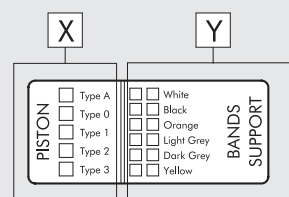

BANDS SUPPORT KIT POS 1 (Y)

Ø	Code White	Code Black	Code Orange	Code Light grey	Code Dark grey	Code Yellow
16	0090165080	0090165081	0090165082	0090165083	0090165084	0090165085
25	0090255080	0090255081	0090255082	0090255083	0090255084	0090255085
32	0090325080	0090325081	0090325082	0090325083	0090325084	0090325085
40	0090405080	0090405081	0090405082	0090405083	0090405084	0090405085
63	0090635080	0090635081	0090635082	0090635083	0090635084	0090635085

BANDS KIT (INNER AND OUTER) POS 8-9

Ø	Code
16	0090166...
25	0090256...
32	0090326...
40	0090406...
63	0090636...

"V" GUIDE PLATE KIT POS 11

Ø	Code
25	0090255060
32	0090325060
40	0090325060
63	0090635060

Complete the code with the 4 figure cylinder stroke

PISTON KIT POS 2 (X)

Ø	Code Type 0 (0 rings)	Code Type 1 (1 rings)	Code Type 2 (2 rings)	Code Type 3 (3 rings)	Code Type A (4 rings)
16	0090165015	0090165016	0090165017	0090165018	-
25	0090255015	0090255016	0090255017	0090255018	0090255019
32	0090325015	0090325016	0090325017	0090325018	0090325019
40	0090405015	0090405016	0090405017	0090405018	-
63	0090635015	0090635016	0090635017	0090635018	-

NBR GASKET KIT POS 3-4-5-6-7-10

Ø	Code
16	0090165022
25	0090255022
32	0090325022
40	0090405022
63	0090635022

FKM/FPM GASKET KIT POS 3-4-5-6-7-10

Ø	Code
16	0090165023
25	0090255023
32	0090325023
40	0090405023
63	0090635023

NOTES

If the ends of the carriage appear as below indicated, please contact our commercial department for the spare parts

"INTERMEDIATE RELEASE"

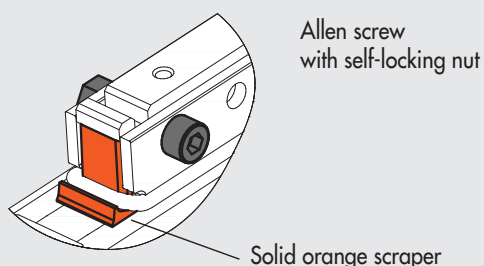

"OLD RELEASE"

