

A standard in-line 4mm banana plug with a stainless steel contact spring.
 The large rear diameter of this plug will accept cables with a conductor of up 5,5mm (10 awg). The lead wire can be held either by soldering in a large solder bucket, or by a set screw. When the cable is held by the set screw, the solder bucket can also be crimped for added strength. Gold plating reduces contact resistance. (Suitable crimping tool - Daniels Manufacturing D36 Hydraulic Crimper).

The product is also supplied with a large diameter insulating cover that accepts cables with a maximum outside diameter of 7,1mm.

Dimensions

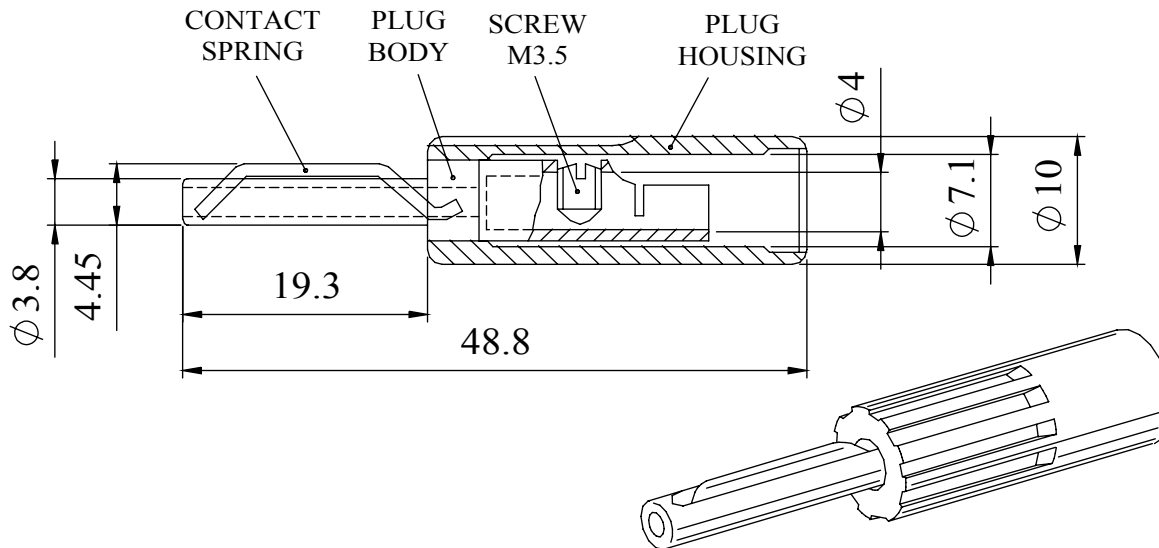

MATERIAL

- CONTACT SPRING PLUG BODY SCREW PLUG HOUSING** : Stainless Steel, BS 302
- PLUG BODY** : Brass, TR1 CZ 131 gold plated
- SCREW** : Brass, BS 2874
- PLUG HOUSING** : Acetal, C 27021 R
- RATING** : 16 Amps
- VOLTAGE** : 50 Volts max

Part No.	Description	
584-0100	BLACK	(GOLD PLATED)
584-0500	RED	(GOLD PLATED)