

Terminal Protection to IP20



Dims: to DIN 43880  
W. 17.5mm

- ❑ **\*NEW\* 17.5mm DIN rail housing**
- ❑ **Switch Initiated Delay Off (Delay On Release) re-triggerable timing function**
- ❑ **7 Selectable time ranges (0.1 seconds – 100 hours)**
- ❑ **Fine adjustment of selected time range**
- ❑ **Multi-voltage input (12 – 230V AC/DC)**
- ❑ **External trigger input can be from Voltage Free Contact or Solid State**
- ❑ **Timer will still function with load connected to trigger (B1) input**
- ❑ **1 x SPDT relay output 8A**
- ❑ **Green LED indication for supply / timing status**
- ❑ **Red LED indication for relay status**
- ❑ **Conforms to IEC 61812**



ISO 9001:2015  
Cert. No. 14125771

### FUNCTION DIAGRAM

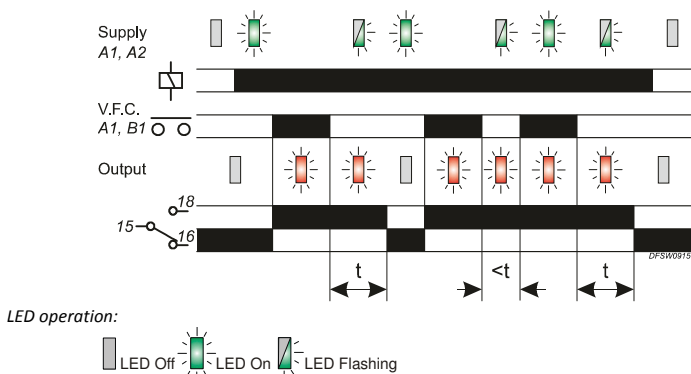

### INSTALLATION AND SETTING

- BEFORE INSTALLATION, ISOLATE THE SUPPLY.
- Connect the unit as required.

Installation work must be carried out by qualified personnel.

#### Setting the unit.

- Set the "Range" ④ to the required position (depending on whether seconds, minutes or hours are required).
- Set the "Set %" adjustment ③ as required. The "Set %" is a % of the selected range; so for example, a 30% setting on the 1 – 10 hour range will give 3 hours.

#### Applying power.

- Apply power across terminals **A1** and **A2** and the green LED ① will illuminate.
- The relay will remain de-energised (contacts **15 / 16** closed and **15 / 18** open) and red LED ② extinguished.
- Close the contact across **A1** and **B1** and the relay will energise (contacts **15 / 16** open and **15 / 18** closed) and red LED illuminate.
- When the contact across **A1** and **B1** opens, the delay period "t" will begin and the green LED will flash to indicate timing is now in progress.
- After the delay period "t" has elapsed, the relay will de-energise (contacts **15 / 16** closed and **15 / 18** open) and the red LED will extinguish.
- The green LED will now remain permanently lit.
- The whole timing process is repeated by removing and re-applying power.
- If during the time period "t", the contact across **A1** and **B1** closes, timing will stop and restart over again the next time the contact opens.

**Note:**  
<sup>1</sup> In accordance with IEC 61812, the green LED is permitted to extinguish during a voltage dip or momentary interruption of the power supply providing the state of the output relay does not change. The dip / interruption duration and levels are defined in the product standard.

### TECHNICAL SPECIFICATION

Supply voltage U (A1, A2):	12 – 230V AC/DC			
Frequency range:	48 - 63Hz (AC supplies)			
Supply variation:	+/- 15%			
Overvoltage category:	III (IEC 60664)			
Rated impulse withstand voltage:	4kV (1.2/50µs) IEC 60664			
Power consumption (max.):	12V	24V	110V	230V
	AC: 0.3VA	0.4VA	1.3VA	3.4VA
	DC: 0.26W	0.24W	0.47W	0.95W

Timing function:	Switch Initiated Delay Off		
Timing ranges (7):	Seconds:	Minutes:	Hours:
	0.1 – 1	0.1 – 1	0.1 – 1
	1 – 10	1 – 10	1 – 10
			10 – 100

Reset time:	100mS
Accuracy:	± 1% of maximum full scale
Adjustment accuracy:	< 5% of maximum full scale
Repeat accuracy:	± 0.5% at constant conditions (IEC 61812)
Drift with temperature:	± 0.05% / °C
Drift with voltage:	± 0.2% / V

External trigger input (A1 > B1):	Volt Free Contact, Open Collector
External loading:	Yes, between B1 and A2 (i.e. LED, Relay, Lamp)
Trigger threshold:	>75% of voltage present between A1 and A2 (auto-set)
Minimum trigger time:	AC: 60mS DC: 40mS (B1 terminal unloaded)
Maximum input frequency:	10 Hz (with 50:50 duty cycle)
Maximum cable length:	10m (between Timer and external switching device)

Power on indication / Timing <sup>1</sup> :	Green LED
Relay status:	Red LED
Ambient temp:	-20 to +60°C
Relative humidity:	+95%
Output (15, 16, 18):	SPDT relay
Output rating:	AC1 250V 8A (2000VA) AC15 250V 5A (no), 3A (nc) DC1 25V 8A (200W)

Electrical life:	≥ 150,000 ops at rated load
Dielectric voltage:	2kV AC (rms) IEC 60947-1
Rated impulse withstand voltage:	4kV (1.2/50µs) IEC 60664

Housing:	Orange flame retardant UL94
Weight:	≈ 60g
Mounting option:	On to 35mm symmetric DIN rail to BS EN 60715 or direct surface mounting via 2 x M3.5 or 4BA screws using the black clips provided on the rear of the unit.

Terminal conductor size	≤ 2 x 2.5mm <sup>2</sup> solid or stranded
-------------------------	--

Approvals: Conforms to IEC 61812.



IND. CONT. EQ. E111187  
 CE, C-tick and RoHS Compliant.  
 EMC: Immunity: EN 61000-6-2 (EN 61000-4-3 10V/m 80MHz - 2.7GHz)  
 Emissions: EN 61000-6-4

### CONNECTION DIAGRAM

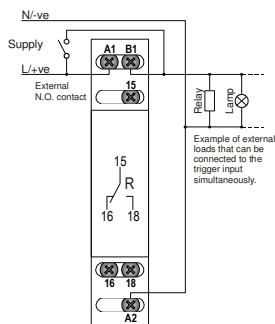

### SETTING DETAILS

1. Power supply status / Timing (Green) LED
2. Relay output status (Red) LED
3. "Set %" adjustment
4. Time delay "Range" selector

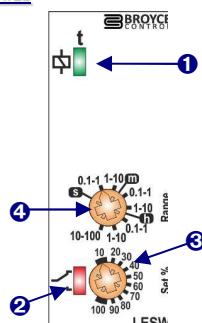

### DIMENSIONS

