

Hall IC Series / Hall IC(Latch type)



# Bipolar Detection Hall ICs

## (With Polarity Discrimination Output)

### BU52004GUL, BU52014HFV

#### ●Description

The BU52004GUL and BU52014HFV are bipolar Hall ICs incorporating a polarity determination circuit that enables operation (output) on both the S- and N-poles, with the polarity judgment based on the output processing configuration. These Hall IC products can be in with movie, mobile phone and other applications involving crystal panels to detect the (front-back) location or determine the rotational direction of the panel.

#### ●Features

- 1) Bipolar detection (polarity detection for both S and N features dual outputs)
- 2) Micropower operation (small current using intermittent operation method)
- 3) Ultra-compact CSP4 package(BU52004GUL)
- 4) Small outline package (BU52014HFV)
- 5) Line up of supply voltage
  - For 1.8V Power supply voltage (BU52014HFV)
  - For 3.0V Power supply voltage (BU52004GUL)
- 6) Polarity judgment and output on both poles (OUT1: S-pole output; OUT2: N-pole output)
- 7) High ESD resistance 8kV(HBM)

#### ●Applications

Mobile phones, notebook computers, digital video camera, digital still camera, etc.

#### ●Product Lineup

Product name	Supply voltage (V)	Operate point (mT)	Hysteresis (mT)	Period (ms)	Supply current (AVG.) ( $\mu$ A)	Output type	Package
BU52004GUL	2.40~3.30	+/-3.7 ※	0.8	50	8.0	CMOS	VCSP50L1
BU52014HFV	1.65~3.30	+/-3.0 ※	0.9	50	5.0	CMOS	HVSOF5

※Plus is expressed on the S-pole; minus on the N-pole

● Absolute Maximum Ratings

BU52004GUL (Ta=25°C)

PARAMETERS	SYMBOL	LIMIT	UNIT
Power Supply Voltage	V <sub>DD</sub>	-0.1~+4.5 <sup>※1</sup>	V
Output Current	I <sub>OUT</sub>	±1	mA
Power Dissipation	P <sub>d</sub>	420 <sup>※2</sup>	mW
Operating Temperature Range	T <sub>opr</sub>	-40~+85	°C
Storage Temperature Range	T <sub>stg</sub>	-40~+125	°C

※1. Not to exceed Pd

※2. Reduced by 4.20mW for each increase in Ta of 1°C over 25°C  
(mounted on 50mm × 58mm Glass-epoxy PCB)

BU52014GUL (Ta=25°C)

PARAMETERS	SYMBOL	LIMIT	UNIT
Power Supply Voltage	V <sub>DD</sub>	-0.1~+4.5 <sup>※3</sup>	V
Output Current	I <sub>OUT</sub>	±0.5	mA
Power Dissipation	P <sub>d</sub>	536 <sup>※4</sup>	mW
Operating Temperature Range	T <sub>opr</sub>	-40~+85	°C
Storage Temperature Range	T <sub>stg</sub>	-40~+125	°C

※3. Not to exceed Pd

※4. Reduced by 5.36mW for each increase in Ta of 1°C over 25°C  
(mounted on 70mm × 70mm × 1.6mm Glass-epoxy PCB)

● Magnetic, Electrical Characteristics

BU52004GUL (Unless otherwise specified, V<sub>DD</sub>=3.0V, Ta=25°C)

PARAMETERS	SYMBOL	LIMIT			UNIT	CONDITIONS
		MIN	TYP	MAX		
Power Supply Voltage	V <sub>DD</sub>	2.4	3.0	3.3	V	
Operate Point	B <sub>opS</sub>	-	3.7	5.5	mT	OUTPUT: OUT1 (respond the south pole)
	B <sub>opN</sub>	-5.5	-3.7	-		OUTPUT: OUT2 (respond the north pole)
Release Point	B <sub>rpS</sub>	0.8	2.9	-	mT	OUTPUT: OUT1 (respond the south pole)
	B <sub>rpN</sub>	-	-2.9	-0.8		OUTPUT: OUT2 (respond the north pole)
Hysteresis	B <sub>hysS</sub>	-	0.8	-	mT	
	B <sub>hysN</sub>	-	0.8	-		
Period	T <sub>p</sub>	-	50	100	ms	
Output High Voltage	V <sub>OH</sub>	V <sub>DD</sub> -0.4	-	-	V	B <sub>rpN</sub> < B < B <sub>rpS</sub> I <sub>OUT</sub> = -1.0mA ※5
Output Low Voltage	V <sub>OL</sub>	-	-	0.4	V	B < B <sub>opN</sub> , B <sub>opS</sub> < B ※5 I <sub>OUT</sub> = +1.0mA
Supply Current	I <sub>DD(AVG)</sub>	-	8	12	μA	Average
Supply Current During Startup Time	I <sub>DD(EN)</sub>	-	4.7	-	mA	During Startup Time Value
Supply Current During Standby Time	I <sub>DD(DIS)</sub>	-	3.8	-	μA	During Standby Time Value

※5. B = Magnetic flux density

1mT=10Gauss

Positive (“+”) polarity flux is defined as the magnetic flux from south pole which is direct toward to the branded face of the sensor.

After applying power supply, it takes one cycle of period (T<sub>p</sub>) to become definite output.

Radiation hardness is not designed.

BU52014HFV (Unless otherwise specified,  $V_{DD}=1.80V$ ,  $T_a=25^{\circ}C$ )

PARAMETERS	SYMBOL	LIMIT			UNIT	CONDITIONS
		MIN	TYP	MAX		
Power Supply Voltage	$V_{DD}$	1.65	1.80	3.30	V	
Operate Point	$B_{opS}$	-	3.0	5.0	mT	OUTPUT: OUT1 (respond the south pole)
	$B_{opN}$	-5.0	-3.0	-		OUTPUT: OUT2 (respond the north pole)
Release Point	$B_{rpS}$	0.6	2.1	-	mT	OUTPUT: OUT1 (respond the south pole)
	$B_{rpN}$	-	-2.1	-0.6		OUTPUT: OUT2 (respond the north pole)
Hysteresis	$B_{hysS}$	-	0.9	-	mT	
	$B_{hysN}$	-	0.9	-		
Period	$T_p$	-	50	100	ms	
Output High Voltage	$V_{OH}$	$V_{DD}$ -0.2	-	-	V	$B_{rpN} < B < B_{rpS}$ $I_{OUT} = -0.5mA$ ※6
Output Low Voltage	$V_{OL}$	-	-	0.2	V	$B < B_{opN}$ , $B_{opS} < B$ $I_{OUT} = +0.5mA$ ※6
Supply Current 1	$I_{DD1(AVG)}$	-	5	8	$\mu A$	$V_{DD}=1.8V$ , Average
Supply Current During Startup Time 1	$I_{DD1(EN)}$	-	2.8	-	mA	$V_{DD}=1.8V$ , During Startup Time Value
Supply Current During Standby Time 1	$I_{DD1(DIS)}$	-	1.8	-	$\mu A$	$V_{DD}=1.8V$ , During Standby Time Value
Supply Current 2	$I_{DD2(AVG)}$	-	8	12	$\mu A$	$V_{DD}=2.7V$ , Average
Supply Current During Startup Time 2	$I_{DD2(EN)}$	-	4.5	-	mA	$V_{DD}=2.7V$ , During Startup Time Value
Supply Current During Standby Time 2	$I_{DD2(DIS)}$	-	4.0	-	$\mu A$	$V_{DD}=2.7V$ , During Standby Time Value

※6. B = Magnetic flux density

1mT=10Gauss

Positive (“+”) polarity flux is defined as the magnetic flux from south pole which is direct toward to the branded face of the sensor.

After applying power supply, it takes one cycle of period ( $T_p$ ) to become definite output.

Radiation hardness is not designed.

● Figure of measurement circuit

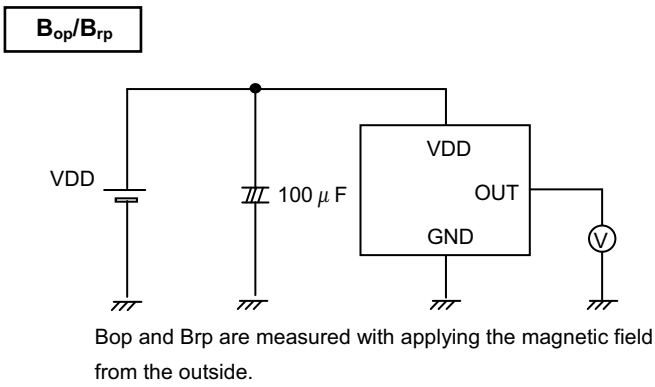

Fig.1 B<sub>op</sub>,B<sub>rp</sub> measurement circuit

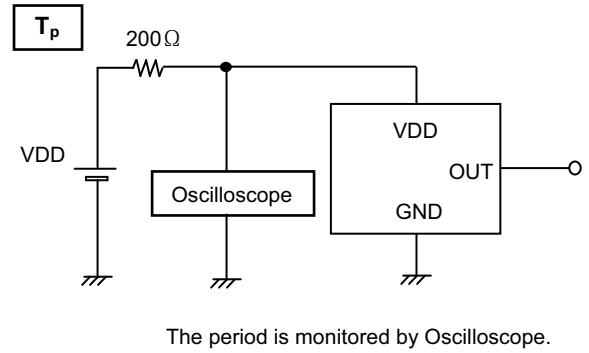

Fig.2 T<sub>p</sub> measurement circuit

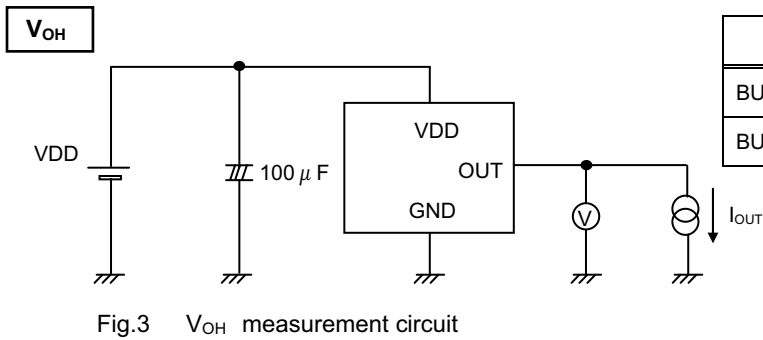

Fig.3 V<sub>OH</sub> measurement circuit

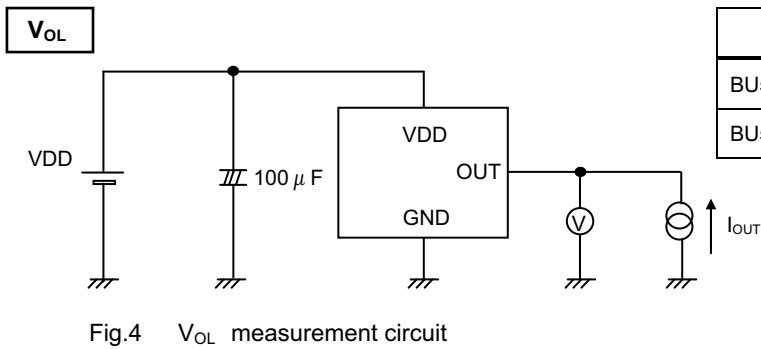

Fig.4 V<sub>OL</sub> measurement circuit

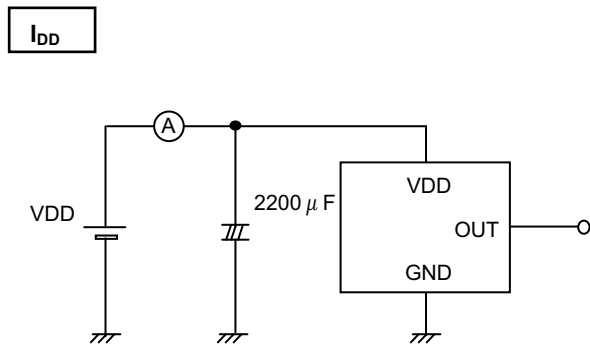

Fig.5 I<sub>DD</sub> measurement circuit

● Technical (Reference) Data

**BU52004GUL ( $V_{DD}=2.4\sim 3.3V$  type)**

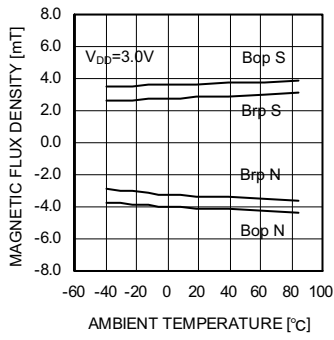

Fig.6 Bop,Brp – Ambient temperature

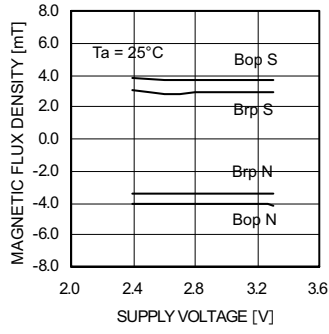

Fig.7 Bop,Brp – Supply voltage

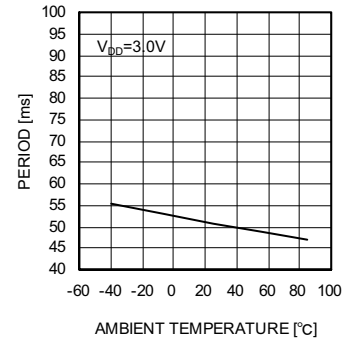

Fig.8  $T_P$  – Ambient temperature

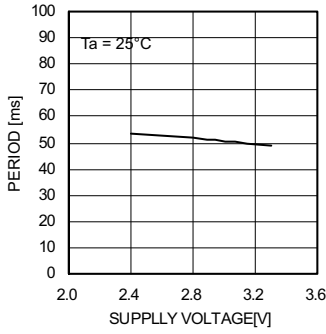

Fig.9  $T_P$  – Supply voltage

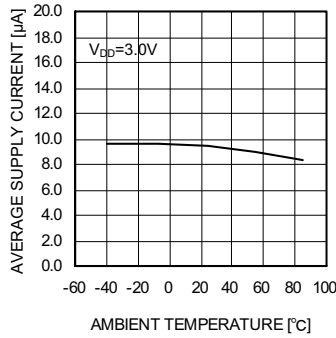

Fig.10  $I_{DD}$  – Ambient temperature

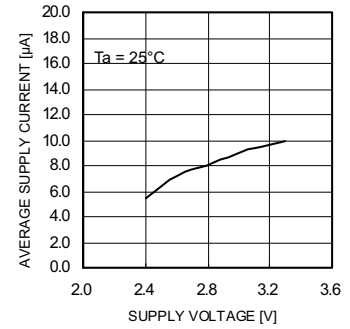

Fig.11  $I_{DD}$  – Supply voltage

**BU52014HFV ( $V_{DD}=1.65\sim 3.3V$  type)**

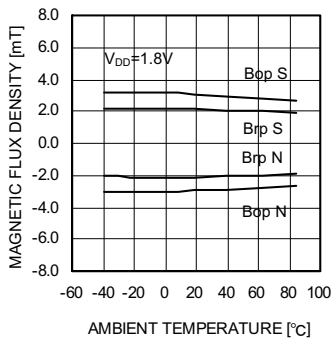

Fig.12 Bop,Brp – Ambient temperature

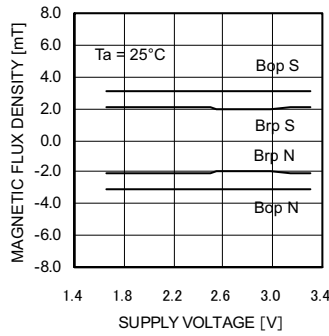

Fig.13 Bop,Brp – Supply voltage

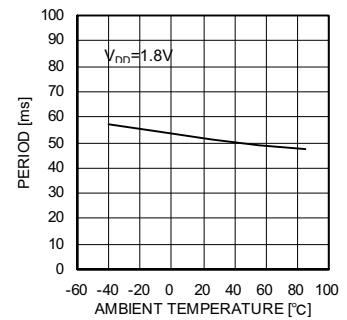

Fig.14  $T_P$  – Ambient temperature

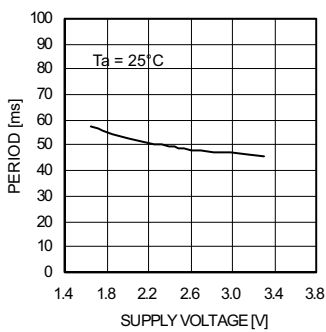

Fig.15  $T_P$  – Supply voltage

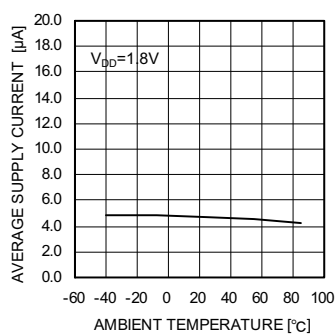

Fig.16  $I_{DD}$  – Ambient temperature

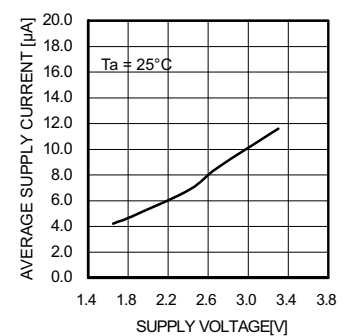

Fig.17  $I_{DD}$  – Supply voltage

● Block Diagram  
**BU52004GUL**

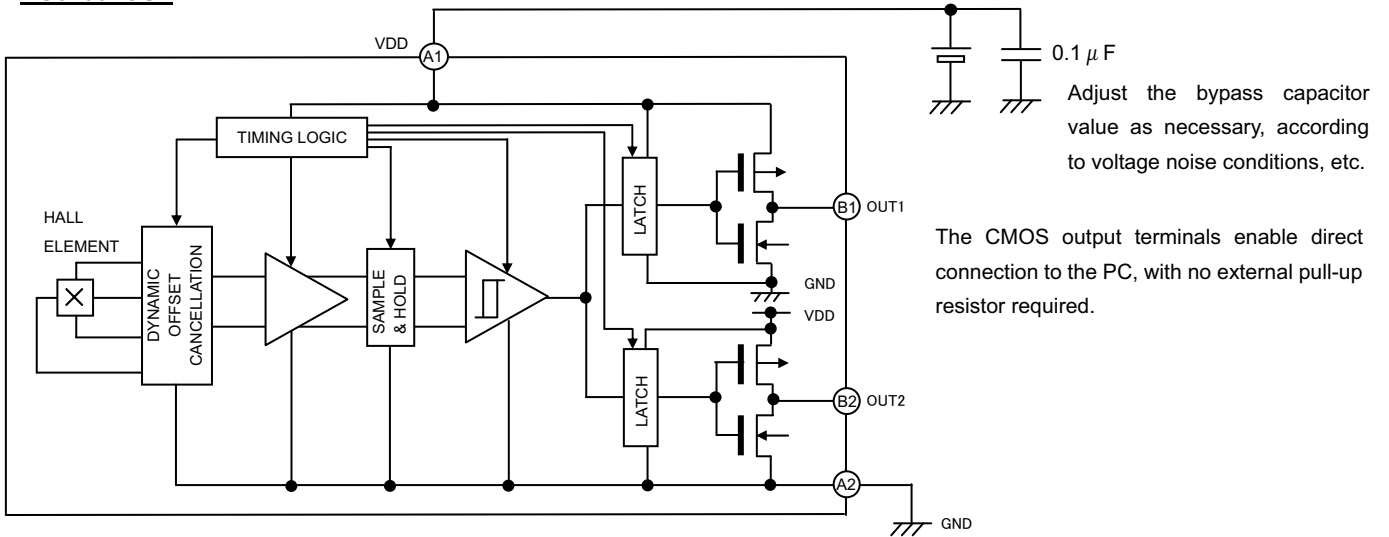
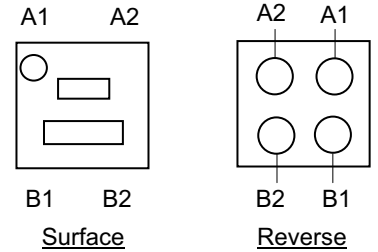

Fig.18

PIN No.	PIN NAME	FUNCTION	COMMENT
A1	VDD	POWER SUPPLY	
A2	GND	GROUND	
B1	OUT1	OUTPUT( respond the south pole)	
B2	OUT2	OUTPUT( respond the north pole)	



**BU52014HFV**

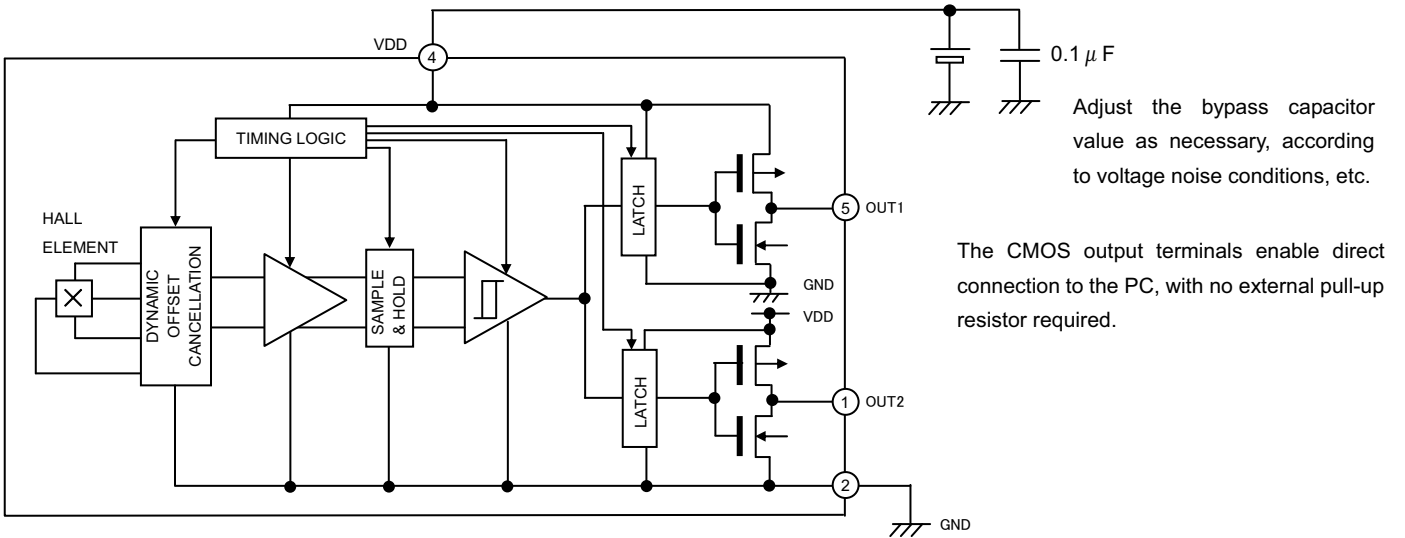
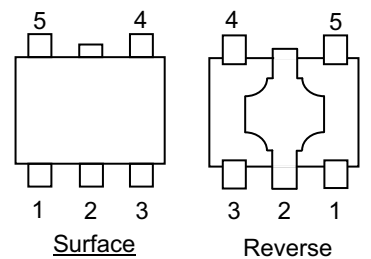

Fig.19

PIN No.	PIN NAME	FUNCTION	COMMENT
1	OUT2	OUTPUT ( respond the north pole)	
2	GND	GROUND	
3	N.C.		OPEN or Short to GND.
4	VDD	POWER SUPPLY	
5	OUT1	OUTPUT ( respond the south pole)	



● Description of Operations

Micropower Operation (Small current using intermittent action)

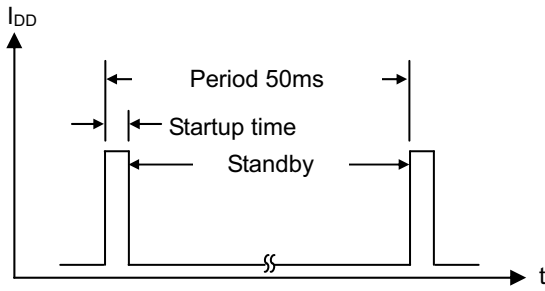

Fig.20

The dual output bipolar detection Hall IC adopts an intermittent operation method to save energy. At startup, the Hall elements, amp, comparator and other detection circuits power ON and magnetic detection begins. During standby, the detection circuits power OFF, thereby reducing current consumption. The detection results are held while standby is active, and then output.

Reference period: 50ms (MAX100ms)

Reference startup time: 48  $\mu$ s

(Offset Cancellation)

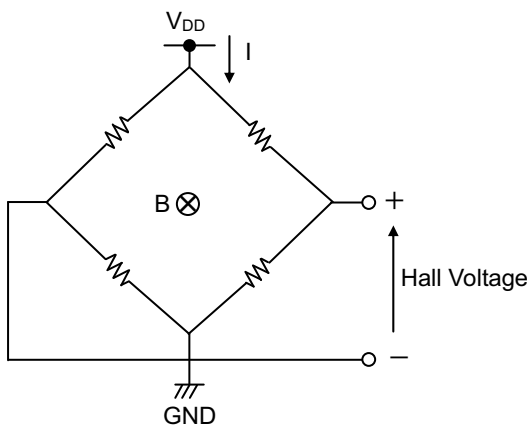

Fig.21

The Hall elements form an equivalent Wheatstone (resistor) bridge circuit. Offset voltage may be generated by a differential in this bridge resistance, or can arise from changes in resistance due to package or bonding stress. A dynamic offset cancellation circuit is employed to cancel this offset voltage.

When Hall elements are connected as shown in Fig. 21 and a magnetic field is applied perpendicular to the Hall elements, voltage is generated at the mid-point terminal of the bridge. This is known as Hall voltage.

Dynamic cancellation switches the wiring (shown in the figure) to redirect the current flow to a 90° angle from its original path, and thereby cancels the Hall voltage.

The magnetic signal (only) is maintained in the sample/hold circuit during the offset cancellation process and then released.

(Magnetic Field Detection Mechanism)

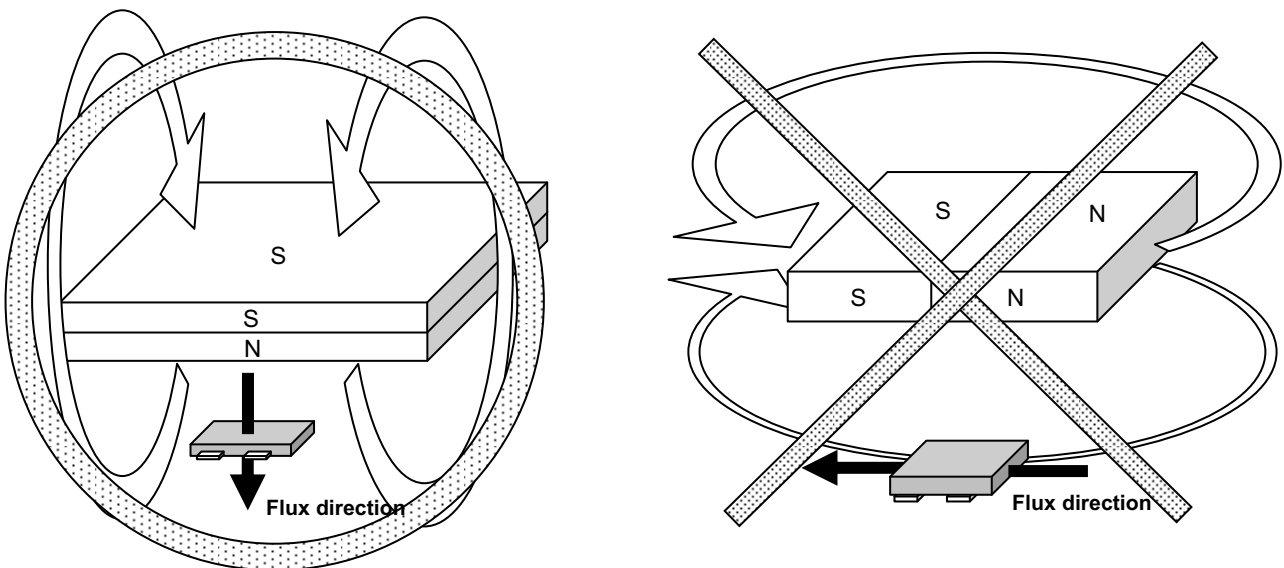

Fig.22

The Hall IC cannot detect magnetic fields that run horizontal to the package top layer. Be certain to configure the Hall IC so that the magnetic field is perpendicular to the top layer.

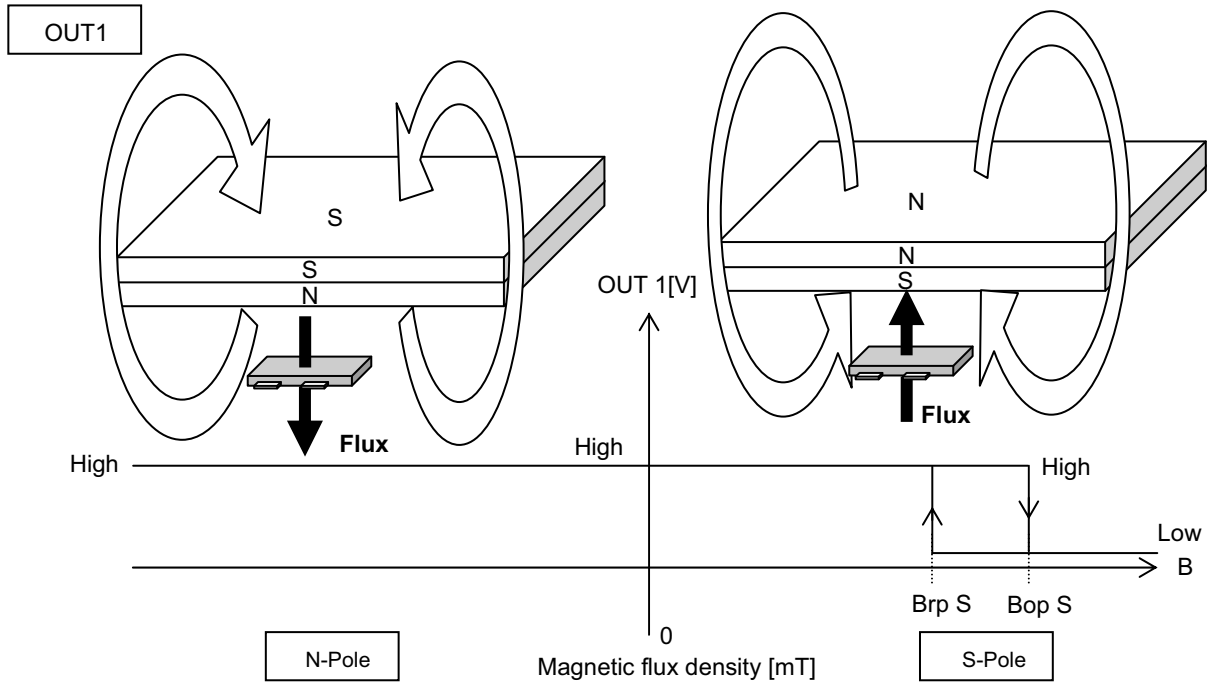

Fig.23 S-Pole Detection

The OUT1 pin detects and outputs for the S-pole only. Since it is unipolar, it does not recognize the N-pole.

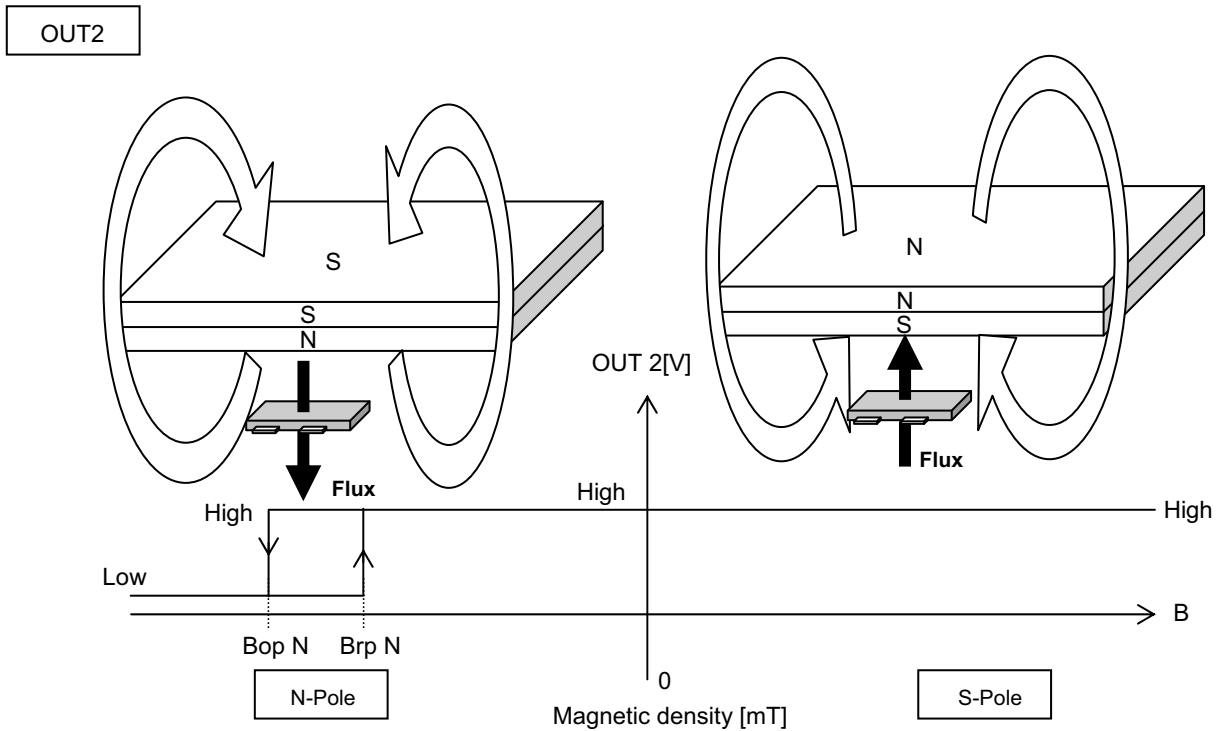

Fig.24 N-Pole Detection

The OUT2 pin detects and outputs for the N-pole only. Since it is unipolar, it does not recognize the S-pole.

The dual output bipolar detection Hall IC detects magnetic fields running perpendicular to the top surface of the package. There is an inverse relationship between magnetic flux density and the distance separating the magnet and the Hall IC: when distance increases magnetic density falls. When it drops below the operate point (Bop), output goes HIGH. When the magnet gets closer to the IC and magnetic density rises, to the operate point, the output switches LOW. In LOW output mode, the distance from the magnet to the IC increases again until the magnetic density falls to a point just below Bop, and output returns HIGH. (This point, where magnetic flux density restores HIGH output, is known as the release point, Brp.) This detection and adjustment mechanism is designed to prevent noise, oscillation and other erratic system operation.



● Intermittent Operation at Power ON

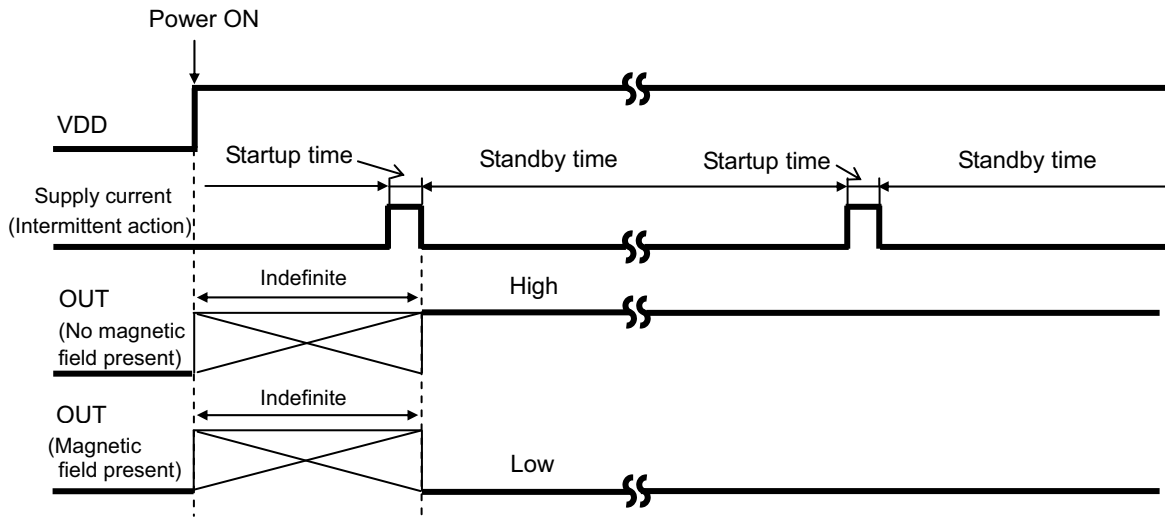

Fig.25

The dual output bipolar detection Hall IC adopts an intermittent operation method in detecting the magnetic field during startup, as shown in Fig. 25. It outputs to the appropriate terminal based on the detection result and maintains the output condition during the standby period. The time from power ON until the end of the initial startup period is an indefinite interval, but it cannot exceed the maximum period, 100ms. To accommodate the system design, the Hall IC output read should be programmed within 100ms of power ON, but after the time allowed for the period ambient temperature and supply voltage.

● Magnet Selection

Of the two representative varieties of permanent magnet, neodymium generally offers greater magnetic power per volume than ferrite, thereby enabling the highest degree of miniaturization. Thus, neodymium is best suited for small equipment applications. Fig. 26 shows the relation between the size (volume) of a neodymium magnet and magnetic flux density. The graph plots the correlation between the distance (L) from three versions of a 4mm X 4mm cross-section neodymium magnet (1mm, 2mm, and 3mm thick) and magnetic flux density. Fig. 27 shows Hall IC detection distance – a good guide for determining the proper size and detection distance of the magnet. Based on the BU52014HFV operating point max 5.0 mT, the minimum detection distance for the 1mm, 2mm and 3mm magnets would be 7.6mm, 9.22mm, and 10.4mm, respectively. To increase the magnet's detection distance, either increase its thickness or sectional area.

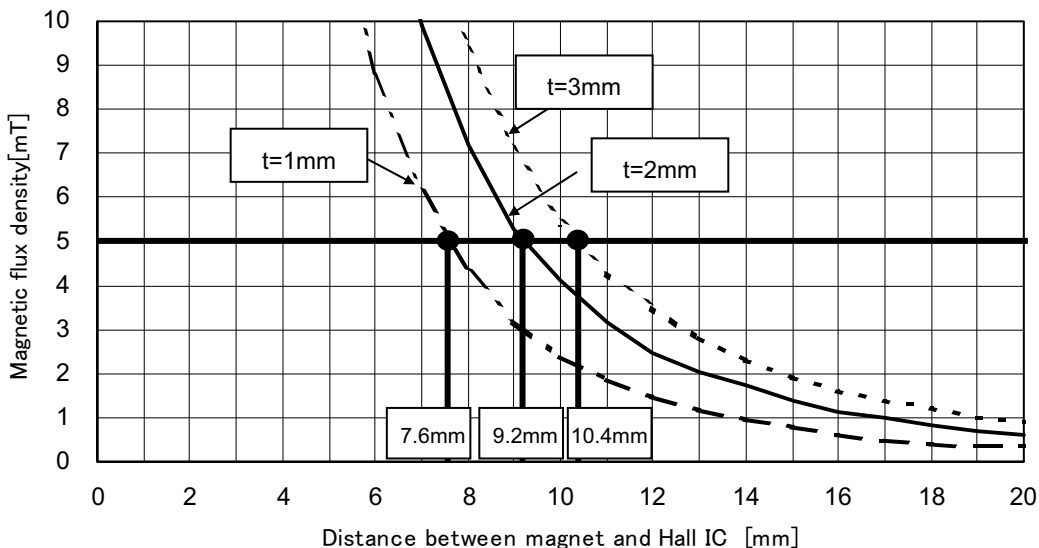
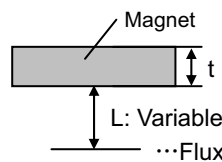
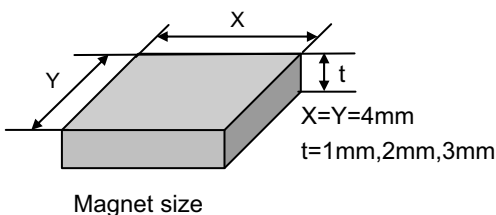

Fig.26



Magnet material: NEOMAX-44H (material)  
 Maker: NEOMAX CO.,LTD.



Fig.27 Magnet Dimensions and Flux Density Measuring Point

●Position of the Hall Effect IC(Reference)

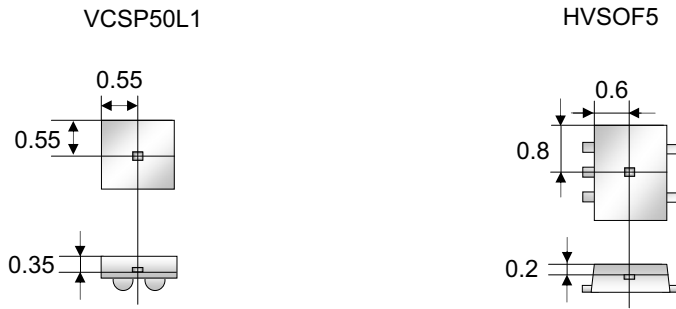

(UNIT : mm)

●Footprint dimensions (Optimize footprint dimensions to the board design and soldering condition)

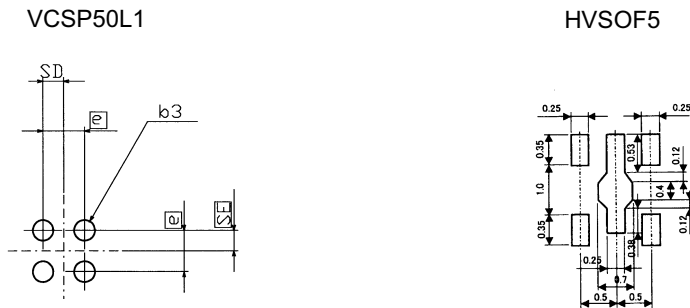

照合文字	寸法 (標準値)
e	0.50
b3	0.25
SD	0.25
SE	0.25

(UNIT : mm)

●Terminal Equivalent Circuit Diagram

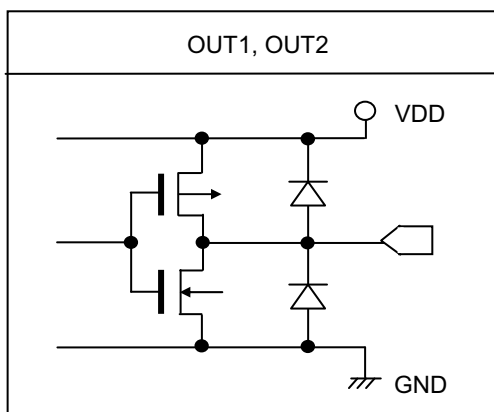

Fig.28

Because they are configured for CMOS (inverter) output, the output pins require no external resistance and allow direct connection to the PC. This, in turn, enables reduction of the current that would otherwise flow to the external resistor during magnetic field detection, and supports overall low current (micropower) operation.

● Operation Notes

1) Absolute maximum ratings

Exceeding the absolute maximum ratings for supply voltage, operating conditions, etc. may result in damage to or destruction of the IC. Because the source (short mode or open mode) cannot be identified if the device is damaged in this way, it is important to take physical safety measures such as fusing when implementing any special mode that operates in excess of absolute rating limits.

2) GND voltage

Make sure that the GND terminal potential is maintained at the minimum in any operating state, and is always kept lower than the potential of all other pins.

3) Thermal design

Use a thermal design that allows for sufficient margin in light of the power dissipation ( $P_d$ ) in actual operating conditions.

4) Pin shorts and mounting errors

Use caution when positioning the IC for mounting on printed circuit boards. Mounting errors, such as improper positioning or orientation, may damage or destroy the device. The IC may also be damaged or destroyed if output pins are shorted together, or if shorts occur between the output pin and supply pin or GND.

5) Positioning components in proximity to the Hall IC and magnet

Positioning magnetic components in close proximity to the Hall IC or magnet may alter the magnetic field, and therefore the magnetic detection operation. Thus, placing magnetic components near the Hall IC and magnet should be avoided in the design if possible. However, where there is no alternative to employing such a design, be sure to thoroughly test and evaluate performance with the magnetic component(s) in place to verify normal operation before implementing the design.

6) Slide-by position sensing

Fig.29 depicts the slide-by configuration employed for position sensing. Note that when the gap ( $d$ ) between the magnet and the Hall IC is narrowed, the reverse magnetic field generated by the magnet can cause the IC to malfunction. As seen in Fig.30, the magnetic field runs in opposite directions at Point A and Point B. Since the dual output bipolar detection Hall IC can detect the S-pole at Point A and the N-pole at Point B, it can wind up switching output ON as the magnet slides by in the process of position detection. Fig. 31 plots magnetic flux density during the magnet slide-by. Although a reverse magnetic field was generated in the process, the magnetic flux density decreased compared with the center of the magnet. This demonstrates that slightly widening the gap ( $d$ ) between the magnet and Hall IC reduces the reverse magnetic field and prevents malfunctions.

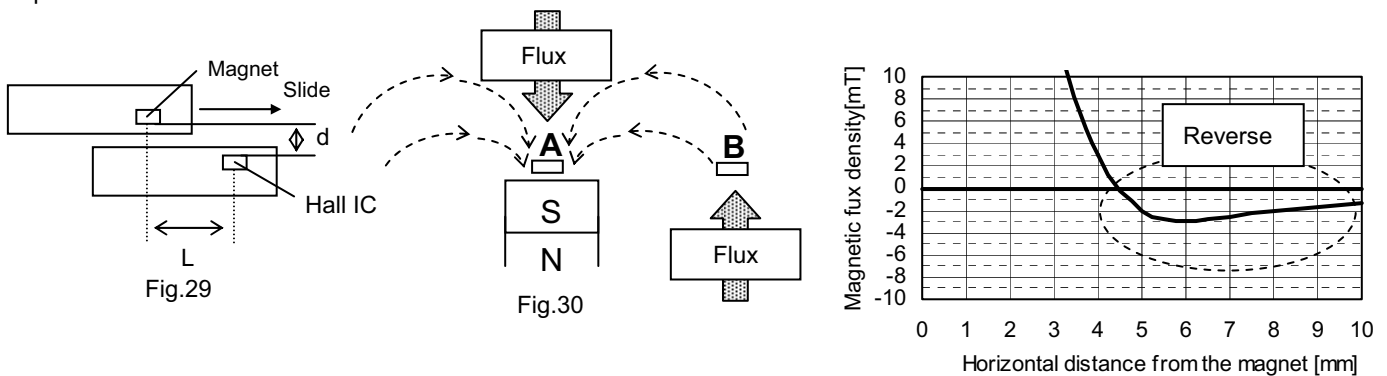

7) Operation in strong electromagnetic fields

Exercise extreme caution about using the device in the presence of a strong electromagnetic field, as such use may cause the IC to malfunction.

8) Common impedance

Make sure that the power supply and GND wiring limits common impedance to the extent possible by, for example, employing short, thick supply and ground lines. Also, take measures to minimize ripple such as using an inductor or capacitor.

9) GND wiring pattern

When both a small-signal GND and high-current GND are provided, single-point grounding at the reference point of the set PCB is recommended, in order to separate the small-signal and high-current patterns, and to ensure that voltage changes due to the wiring resistance and high current do not cause any voltage fluctuation in the small-signal GND. In the same way, care must also be taken to avoid wiring pattern fluctuations in the GND wiring pattern of external components.

10) Exposure to strong light

Exposure to halogen lamps, UV and other strong light sources may cause the IC to malfunction. If the IC is subject to such exposure, provide a shield or take other measures to protect it from the light. In testing, exposure to white LED and fluorescent light sources was shown to have no significant effect on the IC.

11) Power source design

Since the IC performs intermittent operation, it has peak current when it's ON. Please taking that into account and under examine adequate evaluations when designing the power source.

●Product Designations (Selecting a model name when ordering)

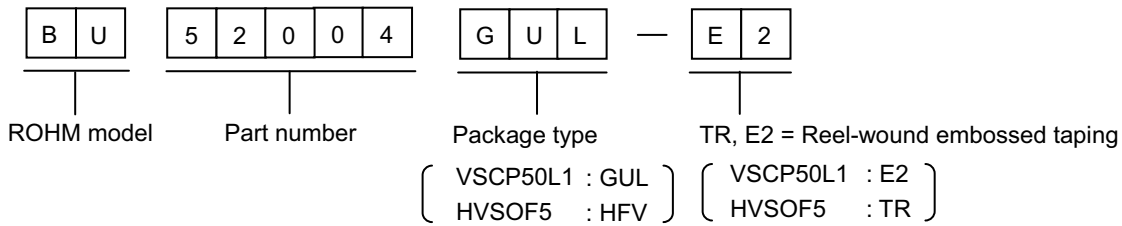

**VCSP50L1**

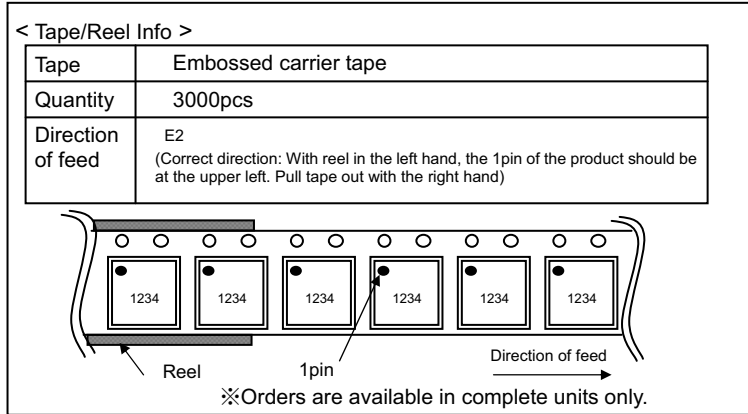
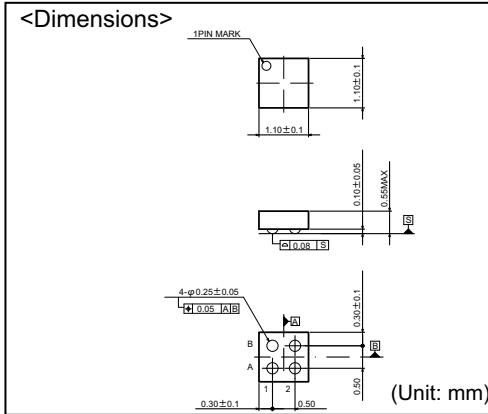

**HVSO5**

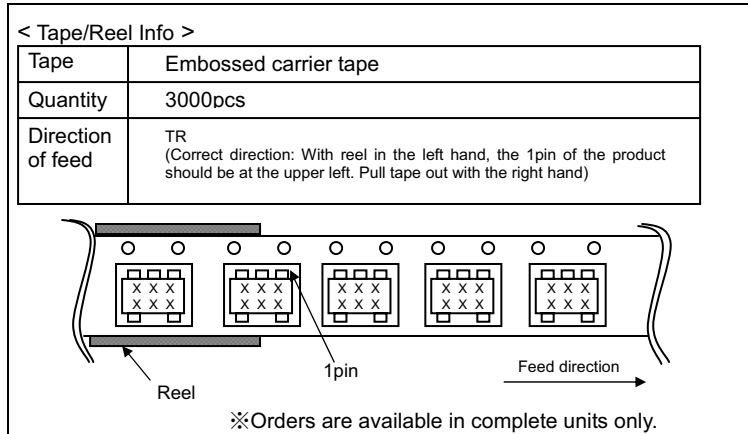
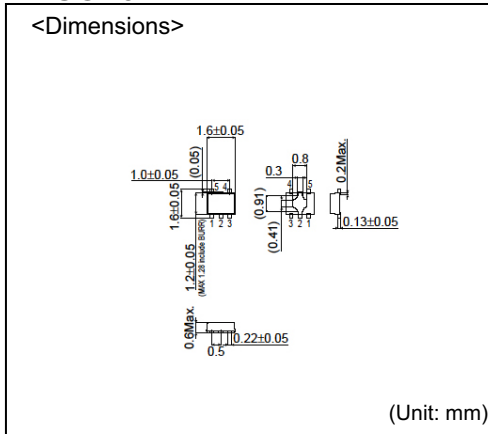

- The contents described herein are correct as of June, 2008
- The contents described herein are subject to change without notice. For updates of the latest information, please contact and confirm with ROHM CO.,LTD.
- Any part of this application note must not be duplicated or copied without our permission.
- Application circuit diagrams and circuit constants contained herein are shown as examples of standard use and operation. Please pay careful attention to the peripheral conditions when designing circuits and deciding upon circuit constants in the set.
- Any data, including, but not limited to application circuit diagrams and information, described herein are intended only as illustrations of such devices and not as the specifications for such devices. ROHM CO.,LTD. disclaims any warranty that any use of such devices shall be free from infringement of any third party's intellectual property rights or other proprietary rights, and further, assumes no liability of whatsoever nature in the event of any such infringement, or arising from or connected with or related to the use of such devices.
- Upon the sale of any such devices, other than for buyer's right to use such devices itself, resell or otherwise dispose of the same, implied right or license to practice or commercially exploit any intellectual property rights or other proprietary rights owned or controlled by ROHM CO., LTD. is granted to any such buyer.
- The products described herein utilize silicon as the main material.
- The products described herein are not designed to be X ray proof.

The products listed in this catalog are designed to be used with ordinary electronic equipment or devices (such as audio visual equipment, office-automation equipment, communications devices, electrical appliances and electronic toys). Should you intend to use these products with equipment or devices which require an extremely high level of reliability and the malfunction of which would directly endanger human life (such as medical instruments, transportation equipment, aerospace machinery, nuclear-reactor controllers, fuel controllers and other safety devices), please be sure to consult with our sales representative in advance.

Contact us for further information about the products.

Excellence in Electronics



**ROHM CO., LTD.**

21, Saiin Mizosaki-cho, Ukyo-ku, Kyoto  
615-8585, Japan  
TEL: +81-75-311-2121 FAX: +81-75-315-0172  
URL: <http://www.rohm.com>

Published by  
LSI Business Promotion Dept.

San Diego  
Atlanta  
Boston  
Chicago  
Dallas  
Denver  
Detroit  
Nashville  
Mexico  
Düsseldorf  
Munich  
Stuttgart  
France  
United Kingdom  
Denmark  
Barcelona  
Hungary  
Poland  
Russia  
Seoul  
Masan  
Dalian  
Beijing  
Tianjin

TEL: +1-858-625-3630 FAX: +1-858-625-3670  
TEL: +1-770-754-5972 FAX: +1-770-754-0691  
TEL: +1-978-371-0382 FAX: +1-928-438-7164  
TEL: +1-847-368-1006 FAX: +1-847-368-1008  
TEL: +1-469-287-5366 FAX: +1-469-362-7973  
TEL: +1-303-708-0908 FAX: +1-303-708-0858  
TEL: +1-248-348-9920 FAX: +1-248-348-9942  
TEL: +1-615-620-6700 FAX: +1-615-620-6702  
TEL: +52-33-3123-2001 FAX: +52-33-3123-2002  
TEL: +49-2154-9210 FAX: +49-2154-921400  
TEL: +49-8161-48310 FAX: +49-8161-483120  
TEL: +49-711-72723710 FAX: +49-711-72723720  
TEL: +33-1-5697-3060 FAX: +33-1-5697-3080  
TEL: +44-1-908-306700 FAX: +44-1-908-235788  
TEL: +45-3694-4739 FAX: +45-3694-4789  
TEL: +34-9375-24320 FAX: +34-9375-24410  
TEL: +36-1-4719338 FAX: +36-1-4719339  
TEL: +48-22-5757213 FAX: +48-22-5757001  
TEL: +7-95-980-6755 FAX: +7-95-937-8290  
TEL: +82-2-8182-700 FAX: +82-2-8182-715  
TEL: +82-55-240-6234 FAX: +82-55-240-6236  
TEL: +86-411-8230-8549 FAX: +86-411-8230-8537  
TEL: +86-10-8525-2483 FAX: +86-10-8525-2489  
TEL: +86-22-23029181 FAX: +86-22-23029183

Shanghai  
Hangzhou  
Nanjing  
Ningbo  
Qingdao  
Suzhou  
Wuxi  
Shenzhen  
Dongguan  
Fuzhou  
Guangzhou  
Huizhou  
Xiamen  
Zhuhai  
Hong Kong  
Taipei  
Kaohsiung  
Singapore  
Philippines  
Thailand  
Kuala Lumpur  
Penang  
Kyoto  
Yokohama

TEL: +86-21-6279-2727 FAX: +86-21-6247-2066  
TEL: +86-571-87658072 FAX: +86-571-87658071  
TEL: +86-25-8689-0015 FAX: +86-25-8689-0393  
TEL: +86-574-87654201 FAX: +86-574-87654208  
TEL: +86-532-5779-312 FAX: +86-532-5779-653  
TEL: +86-512-6807-1300 FAX: +86-512-6807-2300  
TEL: +86-510-82702693 FAX: +86-510-82702992  
TEL: +86-755-8307-3008 FAX: +86-755-8307-3003  
TEL: +86-769-8393-3320 FAX: +86-769-8398-4140  
TEL: +86-591-8801-8698 FAX: +86-591-8801-8690  
TEL: +86-20-8364-9796 FAX: +86-20-8364-9707  
TEL: +86-752-205-1054 FAX: +86-752-205-1059  
TEL: +86-592-238-5705 FAX: +86-592-239-8380  
TEL: +86-756-3232-480 FAX: +86-756-3232-460  
TEL: +852-2-740-6262 FAX: +852-2-375-8971  
TEL: +886-7-237-0881 FAX: +886-7-238-7332  
TEL: +886-2-2500-6956 FAX: +886-2-2503-2869  
TEL: +886-7-237-0881 FAX: +886-7-238-7332  
TEL: +65-6332-2322 FAX: +65-6332-5662  
TEL: +63-2-807-6872 FAX: +63-2-809-1422  
TEL: +66-2-254-4890 FAX: +66-2-256-6334  
TEL: +60-3-7958-8355 FAX: +60-3-7958-8377  
TEL: +60-4-2286453 FAX: +60-4-2286452  
TEL: +81-75-365-1218 FAX: +81-75-365-1228  
TEL: +81-45-476-2290 FAX: +81-45-476-2295

### Notes

- No technical content pages of this document may be reproduced in any form or transmitted by any means without prior permission of ROHM CO.,LTD.
- The contents described herein are subject to change without notice. The specifications for the product described in this document are for reference only. Upon actual use, therefore, please request that specifications to be separately delivered.
- Application circuit diagrams and circuit constants contained herein are shown as examples of standard use and operation. Please pay careful attention to the peripheral conditions when designing circuits and deciding upon circuit constants in the set.
- Any data, including, but not limited to application circuit diagrams information, described herein are intended only as illustrations of such devices and not as the specifications for such devices. ROHM CO.,LTD. disclaims any warranty that any use of such devices shall be free from infringement of any third party's intellectual property rights or other proprietary rights, and further, assumes no liability of whatsoever nature in the event of any such infringement, or arising from or connected with or related to the use of such devices.
- Upon the sale of any such devices, other than for buyer's right to use such devices itself, resell or otherwise dispose of the same, no express or implied right or license to practice or commercially exploit any intellectual property rights or other proprietary rights owned or controlled by
- ROHM CO., LTD. is granted to any such buyer.
- Products listed in this document are no antiradiation design.

The products listed in this document are designed to be used with ordinary electronic equipment or devices (such as audio visual equipment, office-automation equipment, communications devices, electrical appliances and electronic toys).

Should you intend to use these products with equipment or devices which require an extremely high level of reliability and the malfunction of which would directly endanger human life (such as medical instruments, transportation equipment, aerospace machinery, nuclear-reactor controllers, fuel controllers and other safety devices), please be sure to consult with our sales representative in advance.

It is our top priority to supply products with the utmost quality and reliability. However, there is always a chance of failure due to unexpected factors. Therefore, please take into account the derating characteristics and allow for sufficient safety features, such as extra margin, anti-flammability, and fail-safe measures when designing in order to prevent possible accidents that may result in bodily harm or fire caused by component failure. ROHM cannot be held responsible for any damages arising from the use of the products under conditions out of the range of the specifications or due to non-compliance with the NOTES specified in this catalog.

Thank you for your accessing to ROHM product informations.

More detail product informations and catalogs are available, please contact your nearest sales office.

**ROHM** Customer Support System

THE AMERICAS / EUROPE / ASIA / JAPAN

[www.rohm.com](http://www.rohm.com)

Contact us : [webmaster@rohm.co.jp](mailto:webmaster@rohm.co.jp)