DECOSTAR 51 TITAN 50 W 12 V 36° GU5.3

DECOSTAR 51 TITAN | Halogen longlife dichroic reflector lamps 51 mm and glass panel



Areas of application

- General illumination
- Shops
- Restaurants, hotels and similar prestigious applications
- Offices, public buildings

Product benefits

- Brilliant accent light
- Constant bluish appearance of the light escaping at the back of the reflector
- Dichroic reflector reduces the heat in the light beam by up to 66 %
- Constant luminous intensity and constant color location throughout their life
- Flat clear shield
- Approved for use in open luminaires (to IEC 60598-1)
- UV filter
- Contains no mercury

Product features

- Average life: 4,000 h
- Dimmable
- Color rendering index R_a : 100
- Color temperature: 3,000 K



Product datasheet

Technical data

Electrical data

Nominal wattage	50.00 W
Nominal voltage	12 V
Rated wattage	50.00 W
Power factor λ	1.00

Photometrical data

Nominal useful luminous flux 90°	770 lm
Luminous intensity	2200 cd
Color temperature	3000 K
Light color as per EN 12464-1	Warm White
Color rendering index Ra	100
Rated useful luminous flux 90°	770 lm

Light technical data

Beam angle	36 °
Starting time	0.0 s
Warm-up time (60 %)	0.00 s

Dimensions & weight

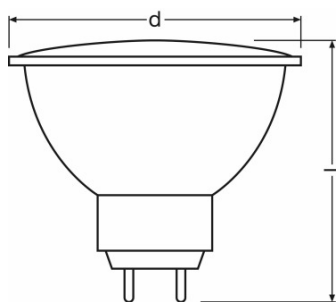

Diameter	51.0 mm
Length	46.0 mm
Overall length	46.0 mm
Outer bulb	MR51
Maximum diameter	51.0 mm

Lifespan

Product datasheet

Nominal lamp life time	4000 h
Rated lamp life time	4000 h
Number of switching cycles	100000 ¹⁾
Lumen main.fact.at end of nom.life time	0.75

¹⁾ At 1 min on / 3 min off

Additional product data

Base (standard designation)	GU5.3
Lamp mercury content	0.0 mg
Mercury-free	Yes

Capabilities

Burning position	Any
Dimmable	Yes

Certificates & standards

Energy efficiency class	B
Energy consumption	53 kWh/1000h

Country specific categorizations

ILCOS	HRGS//UB-50-12-GU5.3-51/36
Order reference	46870 WFL 50W 1

Product datasheet

Light Distribution

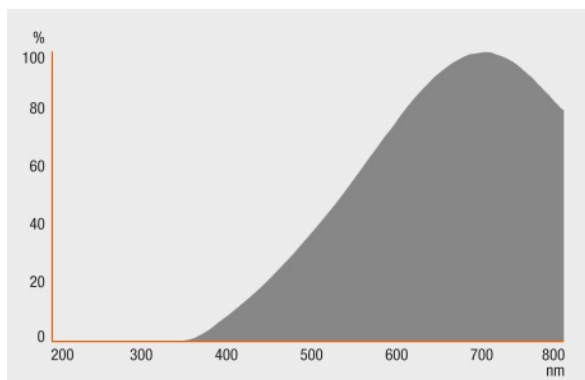

Spectral power distribution

Logistical Data

Product code	Product description	Packaging unit (Pieces/Unit)	Dimensions (length x width x height)	Volume	Gross weight
4050300428772	DECOSTAR 51 TITAN 50 W 12 V 36° GU5.3	Shipping carton box 20	151 mm x 126 mm x 196 mm	3.73 dm ³	836.00 g
4050300462554	DECOSTAR 51 TITAN 50 W 12 V 36° GU5.3	Shipping carton box 20	238 mm x 105 mm x 123 mm	3.07 dm ³	820.00 g

The mentioned product code describes the smallest quantity unit which can be ordered. One shipping unit can contain one or more single products. When placing an order, for the quantity please enter single or multiples of a shipping unit.

References / Links

For light distribution curves see

- ▶ www.osram.com

Disclaimer

Subject to change without notice. Errors and omission excepted. Always make sure to use the most recent release.