



MATERIAL

Body in acetal-based technopolymer, white colour.
Internal support and transfer balls of the main ball in AISI 316 stainless steel.

STANDARD EXECUTIONS

- **UTB-P**: main ball in acetal-based technopolymer (POM), white colour.
- **UTB-SST**: main ball in AISI 316 stainless steel.

FEATURES AND APPLICATIONS

UTB ball transfer units are particularly suitable for applications on transfer and conveyor lines or end of production lines.

They facilitate both linear and rotational movements favouring maximum smoothness (see Technical Data on page 726).

The self-lubricating technopolymer structure ensures maximum cleanliness as it does not require lubrication with oils and greases.

The technopolymer ball lends itself to handling loads with delicate surfaces.

The stainless steel ball lends itself to handling loads with sharp and angular surfaces.

Furthermore, since these are corrosion-resistant materials, it is possible to wash them, even frequently.

ACCESSORIES ON REQUEST

GN 509.3 (see page 727) spring rings in stainless steel to allow easy, quick insertion and removal of UTB units.

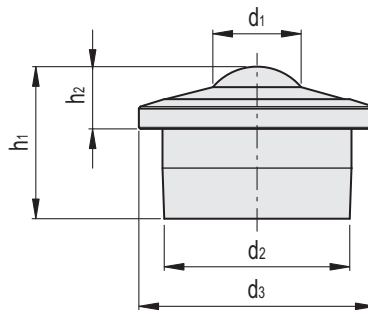

UTB-P

Code	Description	d1	d2	d3	h1	h2	Mounting hole H7	Max load [N]	⚖
470501	UTB.5-P	5.5	10.4	12	8.4	4.3	10.4	150	1
470506	UTB.15-P	15	24	31	21	9.8	24	300	11
470511	UTB.22-P	22	36	45	30	9.8	36	500	30
470516	UTB.30-P	30	45	55	37	13.8	45	950	67

UTB-SST

Code	Description	d1	d2	d3	h1	h2	Mounting hole H7	Max load [N]	⚖
470526	UTB.15-SST	15	24	31	21	9.8	24	300	23
470531	UTB.22-SST	22	36	45	30	9.8	36	500	67



Standard machine parts