

# E20915

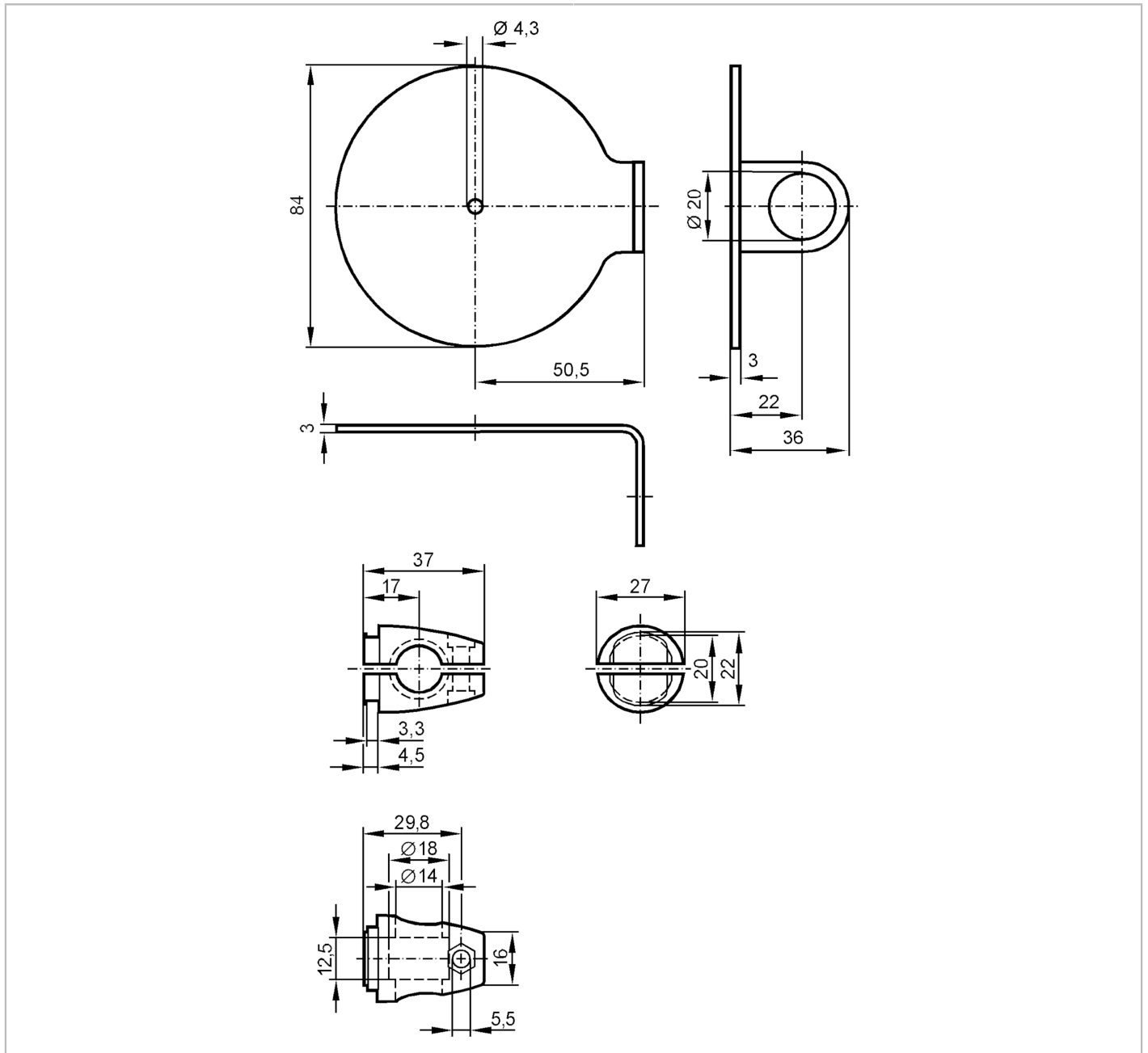

## Mounting set for reflectors

SYSTEM COMPONENT REFL BOLT



Application	
Design	clamp mounting, for reflector, Ø 80 mm
Mechanical data	
Weight [g]	401
Type of mounting	free-standing; (M12)
Materials	fixture: stainless steel (1.4571/316Ti); Clamp: stainless steel (1.4408)
Accessories	
Accessories (supplied)	screw: 1 x M12 x 120
	screw: 1 x M4 x 12
	screw: 1 x M5 x 16
Remarks	
Pack quantity	1 pcs.