

8 CHANNEL MULTIPLEXER/REGISTER (3 STATE)

- HIGH SPEED
 $t_{PD} = 24 \text{ ns (TYP.) AT } V_{CC} = 5 \text{ V}$
- LOW POWER DISSIPATION
 $I_{CC} = 4 \mu\text{A (MAX.) AT } T_A = 25 \text{ }^\circ\text{C}$
- HIGH NOISE IMMUNITY
 $V_{NIH} = V_{NIL} = 28 \% V_{CC} \text{ (MIN.)}$
- OUTPUT DRIVE CAPABILITY
15 LSTTL LOADS
- SYMMETRICAL OUTPUT IMPEDANCE
 $|I_{OH}| = I_{OL} = 6 \text{ mA (MIN.)}$
- BALANCED PROPAGATION DELAYS
 $t_{PLH} = t_{PHL}$
- WIDE OPERATING VOLTAGE RANGE
 $V_{CC} \text{ (OPR)} = 2 \text{ V TO } 6 \text{ V}$
- PIN AND FUNCTION COMPATIBLE
WITH 54/74LS354

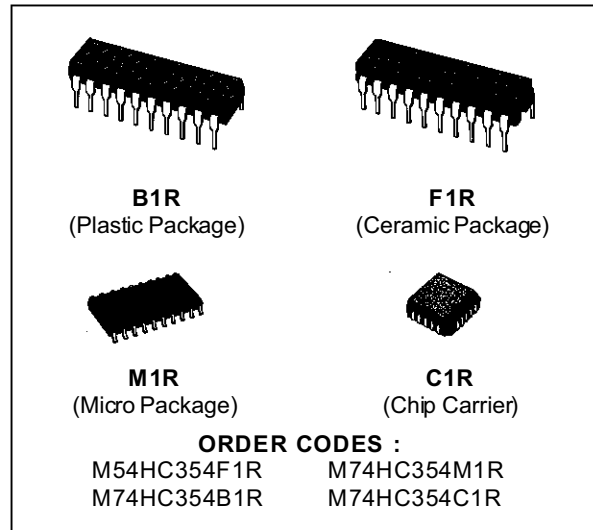

DESCRIPTION

The M54/74HC354 is a high speed CMOS 8-CHANNEL MULTIPLEXER/REGISTER (3-state) fabricated in silicon gate C²MOS technology. It has the same high speed performance of LSTTL combined with true CMOS low consumption.

This device contains an 8 channel digital multiplexer with an 8-bit input data register and a 3-bit address input register with 3-state outputs. The one of eight input data will be provided on the Y output pin (non-inverted output) and W output pin (inverted output) determined by the address data.

The information at the data inputs (D0 to D7) is stored in the 8-bit latch at the negative pulse on \overline{DC} input. The information at the address inputs (S0 to S2) is stored in the 3-bit latch at the negative pulse on \overline{SC} input. These outputs are disabled to be high-impedance when input $\overline{G1}$ is held high, input $\overline{G2}$ is held high or input $\overline{G3}$ is held low. This device is suitable for interfacing with bus lines in a bus organized system.

The M54/74HC354 is similar in function to the M54/74HC356, which has an 8-bit flip-flop as the data register instead of an 8-bit latch. All inputs are equipped with protection circuits against static discharge and transient excess voltage.

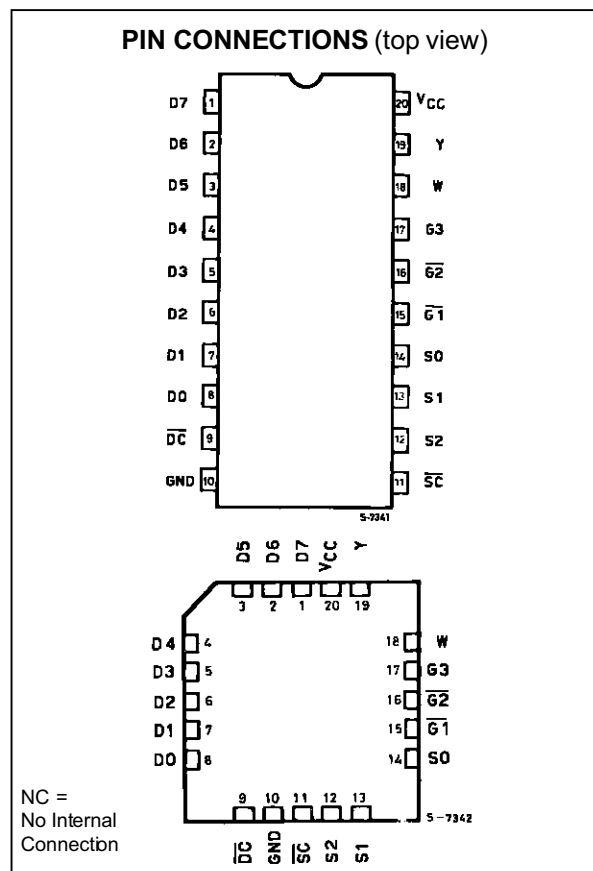

INPUT AND OUTPUT EQUIVALENT CIRCUIT

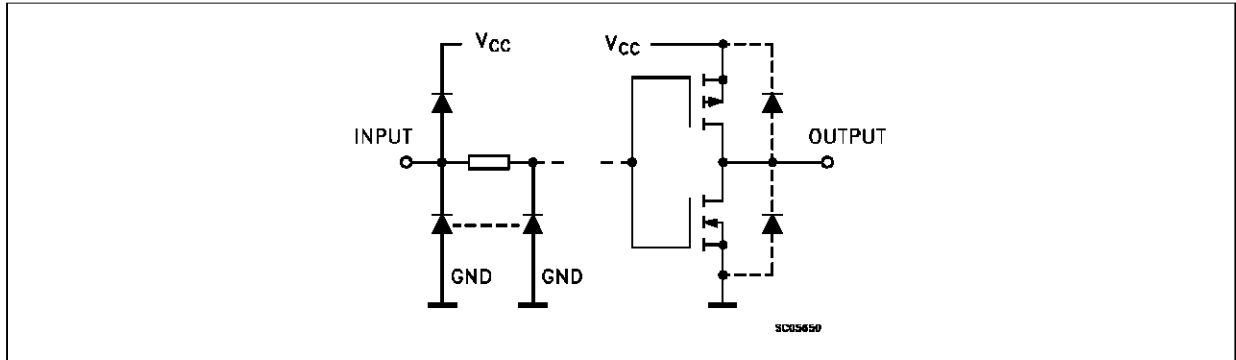

LOGIC DIAGRAM

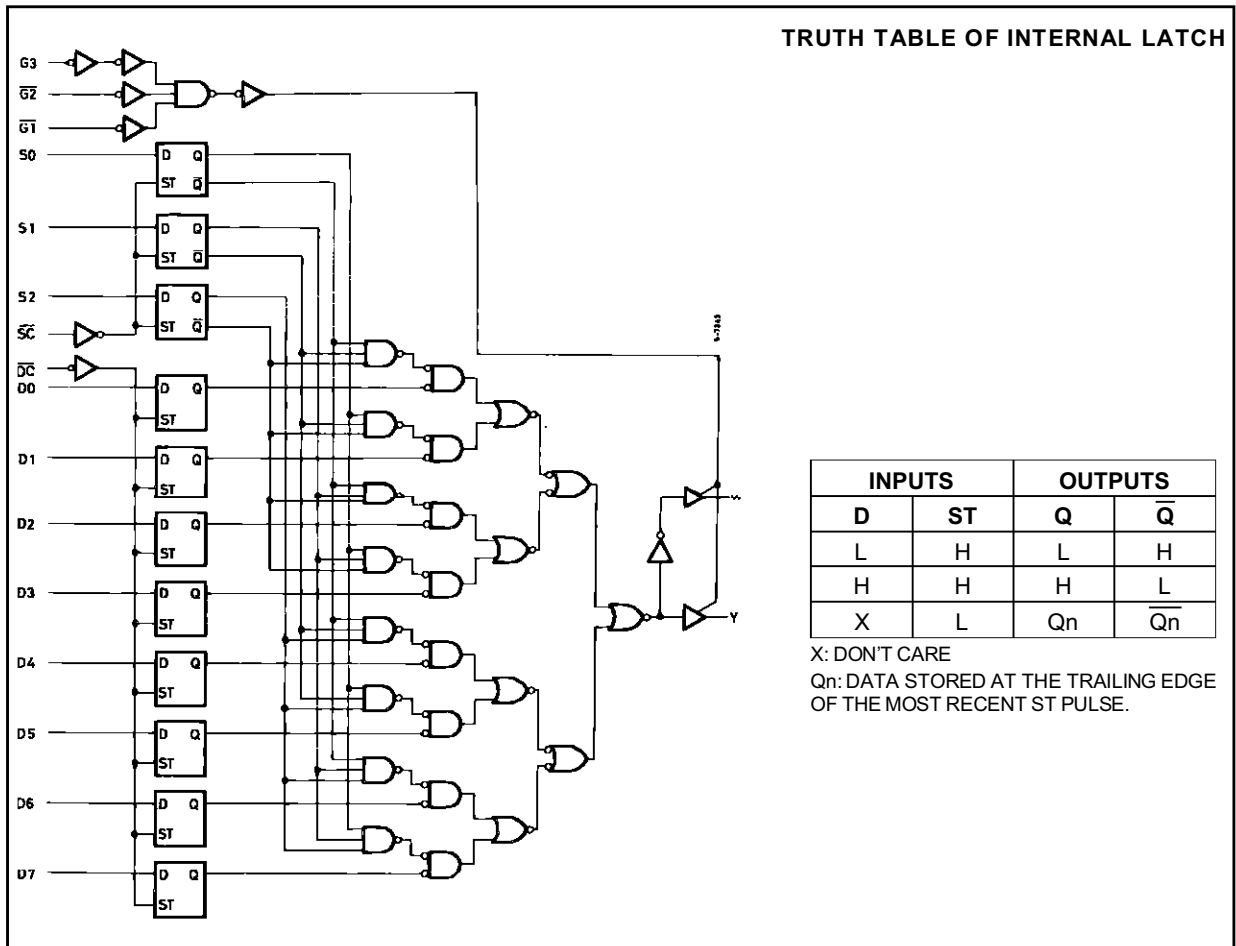

TRUTH TABLE OF INTERNAL LATCH

INPUTS		OUTPUTS	
D	ST	Q	\bar{Q}
L	H	L	H
H	H	H	L
X	L	Q _n	\bar{Q}_n

X: DON'T CARE
 Q_n: DATA STORED AT THE TRAILING EDGE OF THE MOST RECENT ST PULSE.

TRUTH TABLE

SELECT *			INPUTS				OUTPUTS	
S2	S1	S0	DC	OUTPUT ENABLES			W	Y
				G1	G2	G3		
X	X	X	X	H	X	X	Z	Z
X	X	X	X	X	H	X	Z	Z
X	X	X	X	X	X	L	Z	Z
L	L	L	L	L	L	H	$\overline{D0}$	D0
L	L	L	H	L	L	H	$\overline{D0n}$	D0n
L	L	H	L	L	L	H	$\overline{D1}$	D1
L	L	H	H	L	L	H	$\overline{D1n}$	D1n
L	H	L	L	L	L	H	$\overline{D2}$	D2
L	H	L	H	L	L	H	$\overline{D2n}$	D2n
L	H	H	L	L	L	H	$\overline{D3}$	D3
L	H	H	H	L	L	H	$\overline{D3n}$	D3n
H	L	L	L	L	L	H	$\overline{D4}$	D4
H	L	L	H	L	L	H	$\overline{D4n}$	D4n
H	L	H	L	L	L	H	$\overline{D5}$	D5
H	L	H	H	L	L	H	$\overline{D5n}$	D5n
H	H	L	L	L	L	H	$\overline{D6}$	D6
H	H	L	H	L	L	H	$\overline{D6n}$	D6n
H	H	H	L	L	L	H	$\overline{D7}$	D7
H	H	H	H	L	L	H	$\overline{D7n}$	D7n

X: DON'T CARE Z: HIGH IMPEDANCE *: THIS COLUMN SHOWS THE INPUT ADDRESS SETUP WITH SC LOW
D0n....D7n: THE LEVEL OF STEADY-STATE INPUTS AT INPUT D0 THROUGH D7, RESPECTIVELY, BEFORE THE MOST RECENT LOW TO HIGH TRANSITION OF DATA CONTROL.

PIN DESCRIPTION

PIN No	SYMBOL	NAME AND FUNCTION
8, 7, 6, 5, 4, 3, 2, 1	D0 to D7	Data Inputs
9	DC	Data Enable Input (Active LOW)
11	SC	Latch Enable Input (Active LOW)
14, 13, 12	S0, S1, S2	Select Inputs
15, 16	G1, G2	Output Enable Inputs (Active LOW)
17	G3	Output Enable Input (Active HIGH)
18	W	3 State Multiplexer Output (Active LOW)
19	Y	3 State Multiplexer Output (Active HIGH)
10	GND	Ground (0V)
20	Vcc	Positive Supply Voltage

IEC LOGIC SYMBOL

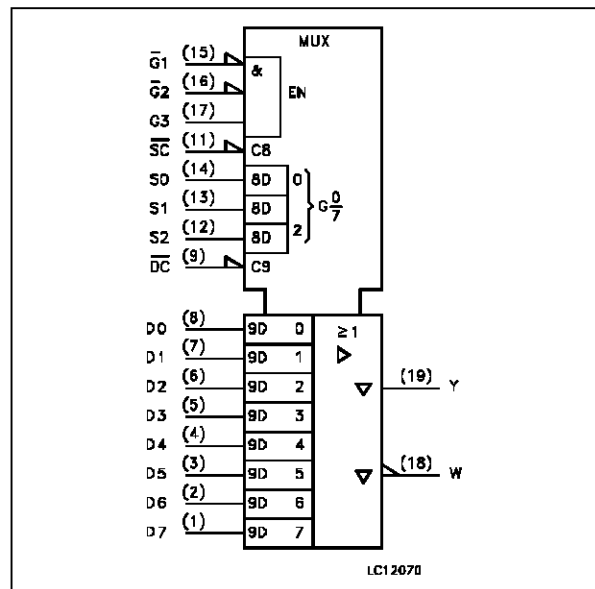

ABSOLUTE MAXIMUM RATING

Symbol	Parameter	Value	Unit
V _{CC}	Supply Voltage	-0.5 to +7	V
V _I	DC Input Voltage	-0.5 to V _{CC} + 0.5	V
V _O	DC Output Voltage	-0.5 to V _{CC} + 0.5	V
I _{IK}	DC Input Diode Current	± 20	mA
I _{OK}	DC Output Diode Current	± 20	mA
I _O	DC Output Source Sink Current Per Output Pin	± 35	mA
I _{CC} or I _{GND}	DC V _{CC} or Ground Current	± 70	mA
P _D	Power Dissipation	500 (*)	mW
T _{stg}	Storage Temperature	-65 to +150	°C
T _L	Lead Temperature (10 sec)	300	°C

Absolute Maximum Ratings are those values beyond which damage to the device may occur. Functional operation under these condition is not implied.

(*) 500 mW: ≅ 65 °C derate to 300 mW by 10mW/°C: 65 °C to 85 °C

RECOMMENDED OPERATING CONDITIONS

Symbol	Parameter	Value	Unit	
V _{CC}	Supply Voltage	2 to 6	V	
V _I	Input Voltage	0 to V _{CC}	V	
V _O	Output Voltage	0 to V _{CC}	V	
T _{op}	Operating Temperature: M54HC Series M74HC Series	-55 to +125 -40 to +85	°C °C	
t _r , t _f	Input Rise and Fall Time	V _{CC} = 2 V V _{CC} = 4.5 V V _{CC} = 6 V	0 to 1000 0 to 500 0 to 400	ns

DC SPECIFICATIONS

Symbol	Parameter	Test Conditions		Value						Unit		
		V _{CC} (V)		T _A = 25 °C 54HC and 74HC			-40 to 85 °C 74HC		-55 to 125 °C 54HC			
				Min.	Typ.	Max.	Min.	Max.	Min.		Max.	
V _{IH}	High Level Input Voltage	2.0		1.5			1.5		1.5		V	
		4.5		3.15			3.15		3.15			
		6.0		4.2			4.2		4.2			
V _{IL}	Low Level Input Voltage	2.0				0.5		0.5		0.5	V	
		4.5				1.35		1.35		1.35		
		6.0				1.8		1.8		1.8		
V _{OH}	High Level Output Voltage	2.0	V _I = V _{IH} or V _{IL}	I _O = -20 μA	1.9	2.0		1.9		1.9	V	
		4.5			4.4	4.5		4.4		4.4		
		6.0			5.9	6.0		5.9		5.9		
		4.5	I _O = -6.0 mA	4.18	4.31		4.13		4.10			
		6.0		I _O = -7.8 mA	5.68	5.8		5.63		5.60		
V _{OL}	Low Level Output Voltage	2.0	V _I = V _{IH} or V _{IL}	I _O = 20 μA		0.0	0.1		0.1		V	
		4.5				0.0	0.1		0.1			0.1
		6.0				0.0	0.1		0.1			0.1
		4.5	I _O = 6.0 mA		0.17	0.26		0.33		0.40		
		6.0		I _O = 7.8 mA		0.18	0.26		0.33			0.40
I _I	Input Leakage Current	6.0	V _I = V _{CC} or GND				±0.1		±1		μA	
I _{OZ}	3 State Output Off State Current	6.0	V _I = V _{IH} or V _{IL} V _O = V _{CC} or GND				±0.5		±5.0		±10	μA
I _{CC}	Quiescent Supply Current	6.0	V _I = V _{CC} or GND				4		40		80	μA

AC ELECTRICAL CHARACTERISTICS ($C_L = 50 \text{ pF}$, Input $t_r = t_f = 6 \text{ ns}$)

Symbol	Parameter	Test Conditions			Value						Unit	
		V _{CC} (V)	C _L (pF)		T _A = 25 °C 54HC and 74HC			-40 to 85 °C 74HC		-55 to 125 °C 54HC		
					Min.	Typ.	Max.	Min.	Max.	Min.		Max.
t _{TLH} t _{THL}	Output Transition Time	2.0	50		25	60		75		90	ns	
		4.5			7	12		15		18		
		6.0			6	10		13		15		
t _{PLH} t _{PHL}	Propagation Delay Time (Dn, DC - Y, W)	2.0	50		83	210		265		315	ns	
		4.5			26	42		53		63		
		6.0			21	36		45		54		
		2.0	150		99	250		315		375	ns	
		4.5			31	50		63		75		
		6.0			25	43		54		64		
t _{PLH} t _{PHL}	Propagation Delay Time (Sn - Y, W)	2.0	50		98	260		325		390	ns	
		4.5			30	52		65		78		
		6.0			25	44		55		66		
		2.0	150		114	300		375		450	ns	
		4.5			35	60		75		90		
		6.0			29	51		64		77		
t _{PLH} t _{PHL}	Propagation Delay Time (SC - Y, W)	2.0	50		102	270		340		405	ns	
		4.5			31	54		68		81		
		6.0			27	46		58		69		
		2.0	150		118	310		390		465	ns	
		4.5			36	62		78		93		
		6.0			31	53		66		79		
t _{PZL} t _{PZH}	3 State Output Enable Time	2.0	50	R _L = 1 KΩ		44	125		155		190	ns
		4.5				14	25		31		38	
		6.0				12	21		26		32	
		2.0	150	R _L = 1 KΩ		60	165		205		250	ns
		4.5				19	33		41		50	
		6.0				16	28		35		43	
t _{PLZ} t _{PHZ}	3 State Output Disable Time	2.0	50	R _L = 1 KΩ		42	155		195		235	ns
		4.5				20	31		39		47	
		6.0				17	26		33		40	
t _{W(L)}	Minimum Pulse Width (DC) (SC)	2.0	50		18	75		95		110	ns	
		4.5			6	15		19		22		
		6.0			6	13		16		19		
t _s	Minimum Set-up Time (Dn) (Sn)	2.0	50		10	50		65		75	ns	
		4.5			3	10		13		15		
		6.0			3	9		11		13		
t _h	Minimum Hold Time (Dn) (Sn)	2.0	50			5		5		5	ns	
		4.5				5		5		5		
		6.0				5		5		5		
C _{IN}	Input Capacitance				5	10		10		10	pF	
C _{PD} (*)	Power Dissipation Capacitance				77						pF	

(*) C_{PD} is defined as the value of the IC's internal equivalent capacitance which is calculated from the operating current consumption without load. (Refer to Test Circuit). Average operating current can be obtained by the following equation. $I_{CC(opr)} = C_{PD} \cdot V_{CC} \cdot f_{IN} + I_{CC}$

TEST CIRCUIT I_{CC} (Opr.)

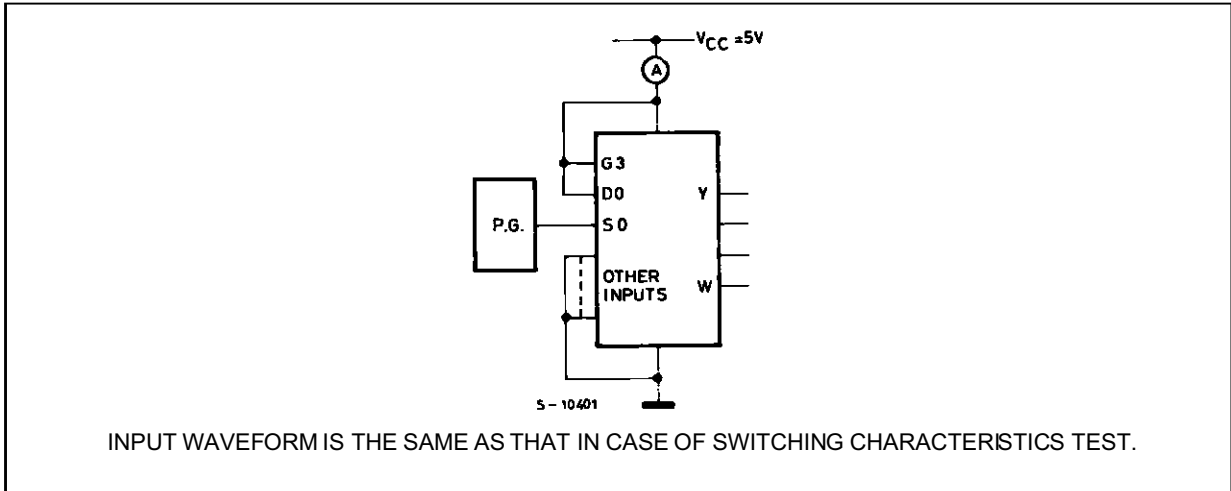

SWITCHING CHARACTERISTICS TEST WAVEFORM

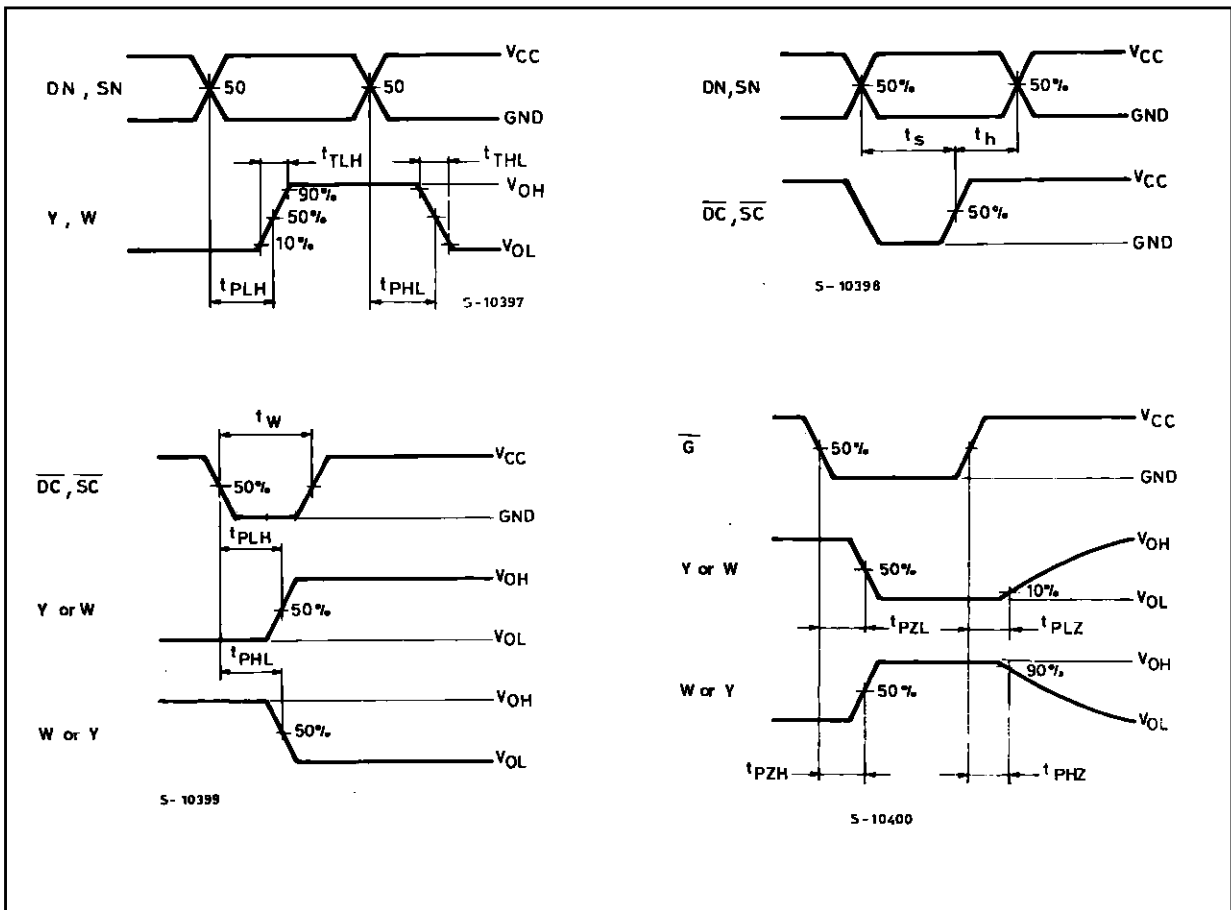

Plastic DIP20 (0.25) MECHANICAL DATA

DIM.	mm			inch		
	MIN.	TYP.	MAX.	MIN.	TYP.	MAX.
a1	0.254			0.010		
B	1.39		1.65	0.055		0.065
b		0.45			0.018	
b1		0.25			0.010	
D			25.4			1.000
E		8.5			0.335	
e		2.54			0.100	
e3		22.86			0.900	
F			7.1			0.280
l			3.93			0.155
L		3.3			0.130	
Z			1.34			0.053

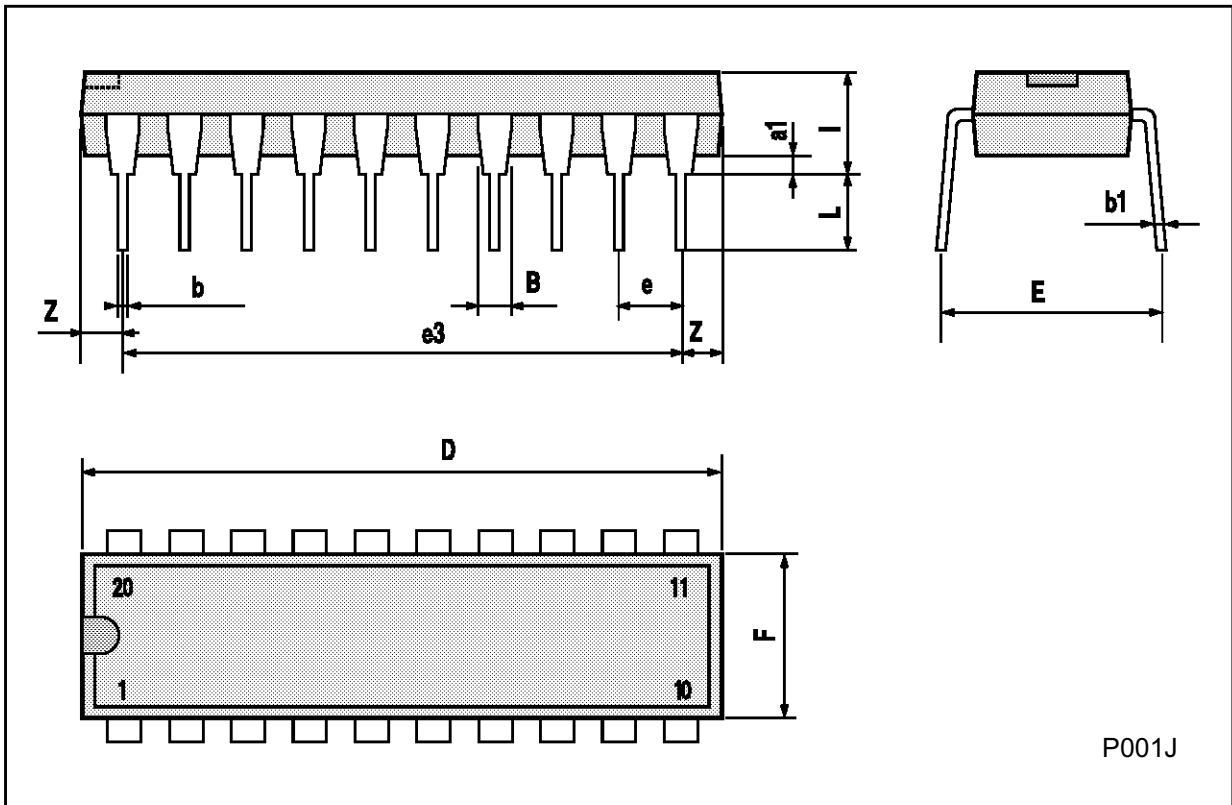

P001J

Ceramic DIP20 MECHANICAL DATA

DIM.	mm			inch		
	MIN.	TYP.	MAX.	MIN.	TYP.	MAX.
A			25			0.984
B			7.8			0.307
D		3.3			0.130	
E	0.5		1.78	0.020		0.070
e3		22.86			0.900	
F	2.29		2.79	0.090		0.110
G	0.4		0.55	0.016		0.022
I	1.27		1.52	0.050		0.060
L	0.22		0.31	0.009		0.012
M	0.51		1.27	0.020		0.050
N1	4° (min.), 15° (max.)					
P	7.9		8.13	0.311		0.320
Q			5.71			0.225

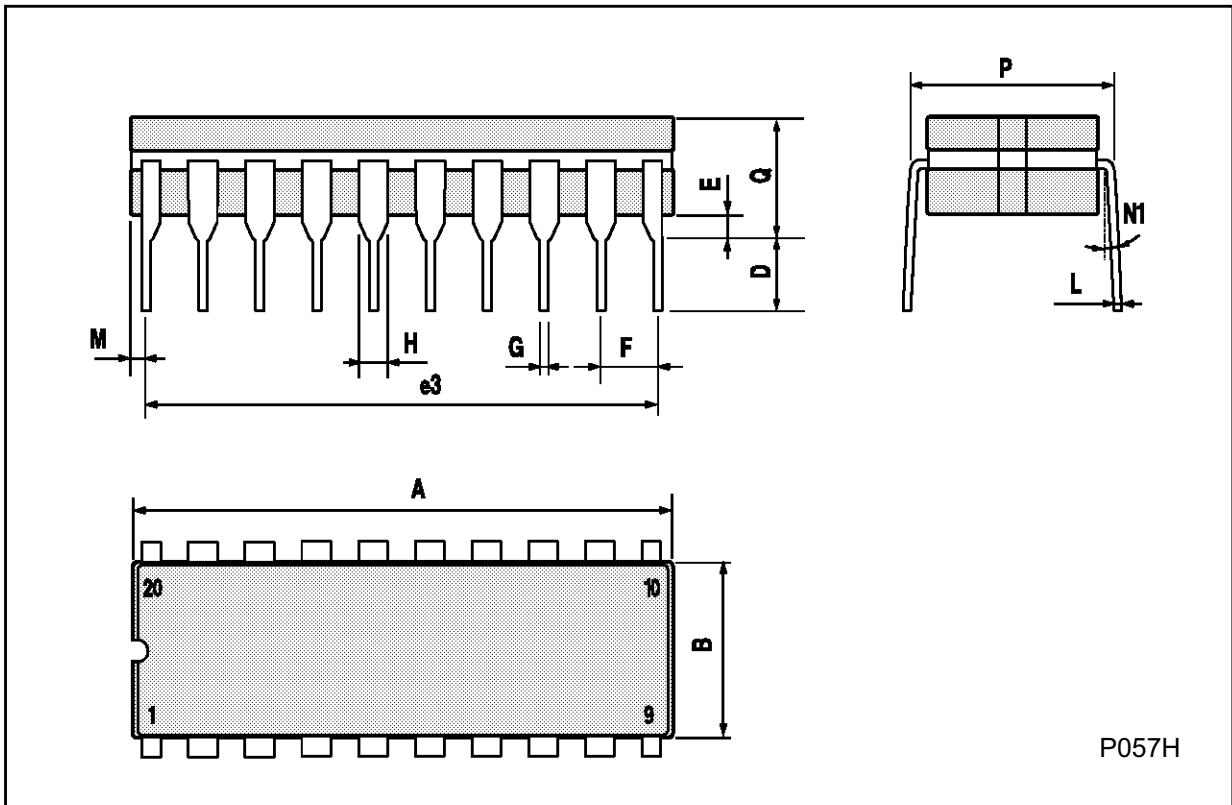

SO20 MECHANICAL DATA

DIM.	mm			inch		
	MIN.	TYP.	MAX.	MIN.	TYP.	MAX.
A			2.65			0.104
a1	0.10		0.20	0.004		0.007
a2			2.45			0.096
b	0.35		0.49	0.013		0.019
b1	0.23		0.32	0.009		0.012
C		0.50			0.020	
c1	45° (typ.)					
D	12.60		13.00	0.496		0.512
E	10.00		10.65	0.393		0.419
e		1.27			0.050	
e3		11.43			0.450	
F	7.40		7.60	0.291		0.299
L	0.50		1.27	0.19		0.050
M			0.75			0.029
S	8° (max.)					

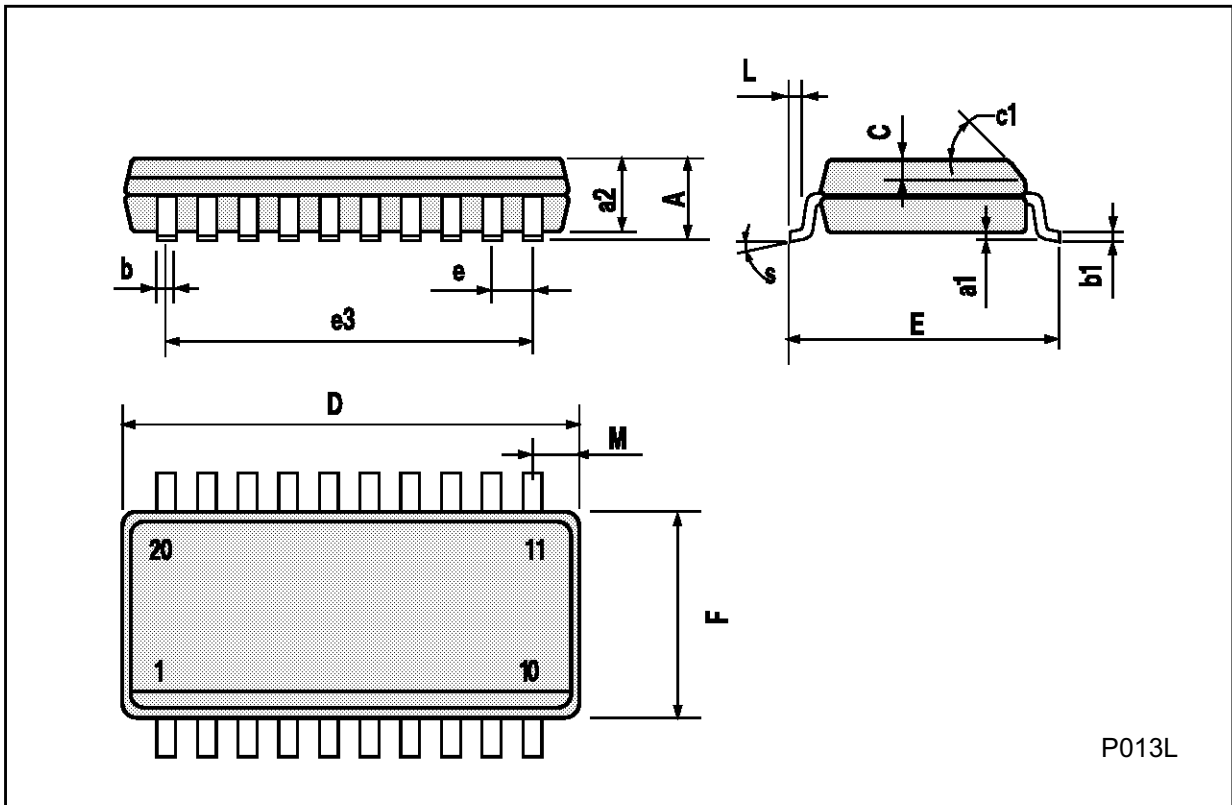

P013L

PLCC20 MECHANICAL DATA

DIM.	mm			inch		
	MIN.	TYP.	MAX.	MIN.	TYP.	MAX.
A	9.78		10.03	0.385		0.395
B	8.89		9.04	0.350		0.356
D	4.2		4.57	0.165		0.180
d1		2.54			0.100	
d2		0.56			0.022	
E	7.37		8.38	0.290		0.330
e		1.27			0.050	
e3		5.08			0.200	
F		0.38			0.015	
G			0.101			0.004
M		1.27			0.050	
M1		1.14			0.045	

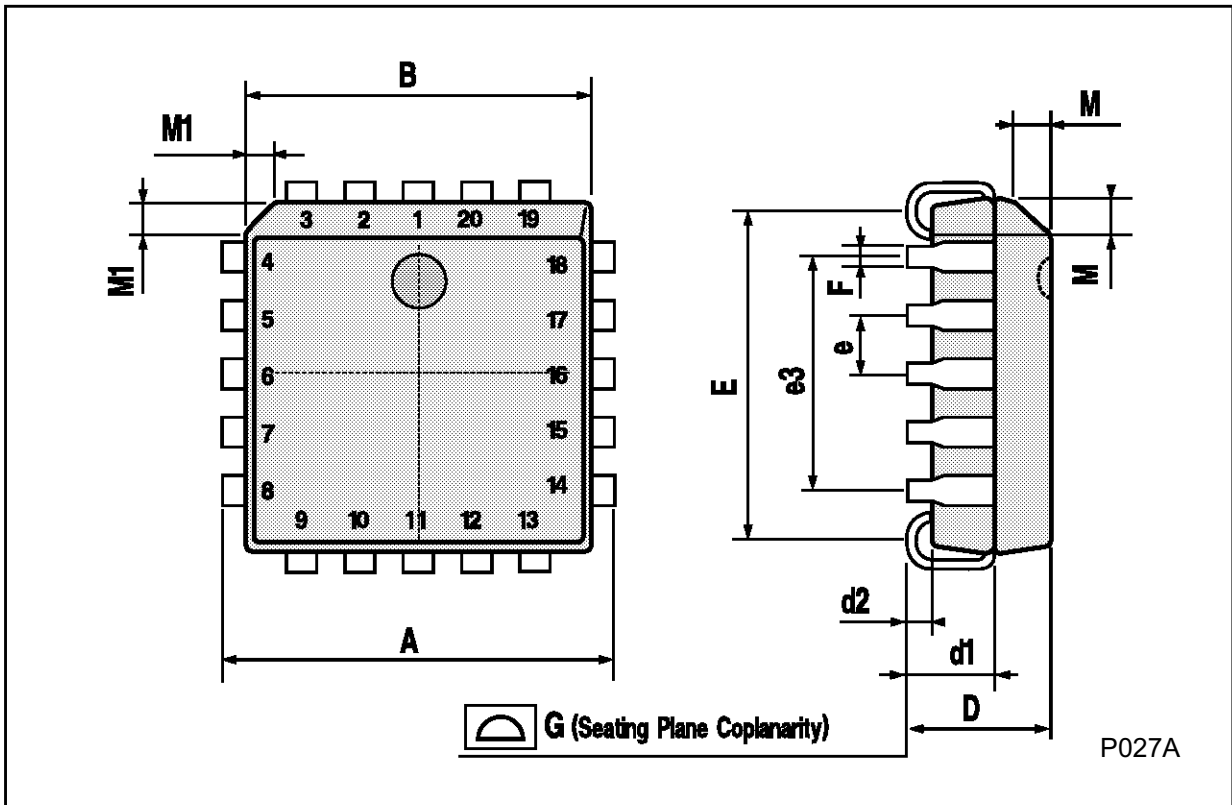

Information furnished is believed to be accurate and reliable. However, SGS-THOMSON Microelectronics assumes no responsibility for the consequences of use of such information nor for any infringement of patents or other rights of third parties which may result from its use. No license is granted by implication or otherwise under any patent or patent rights of SGS-THOMSON Microelectronics. Specifications mentioned in this publication are subject to change without notice. This publication supersedes and replaces all information previously supplied. SGS-THOMSON Microelectronics products are not authorized for use as critical components in life support devices or systems without express written approval of SGS-THOMSON Microelectronics.

© 1994 SGS-THOMSON Microelectronics - All Rights Reserved

SGS-THOMSON Microelectronics GROUP OF COMPANIES
Australia - Brazil - France - Germany - Hong Kong - Italy - Japan - Korea - Malaysia - Malta - Morocco - The Netherlands -
Singapore - Spain - Sweden - Switzerland - Taiwan - Thailand - United Kingdom - U.S.A