

THIS IS A C.A.D. GENERATED DRAWING
DO NOT MAKE MANUAL REVISIONS TO MASTER.

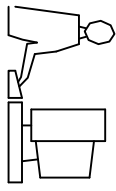

ISSUE NUMBER
ORIGINAL
①

TO OPEN PARTIALLY CLOSED TOOL -
PUSH THIS LATCH IN THE DIRECTION
OF THE ARROW.

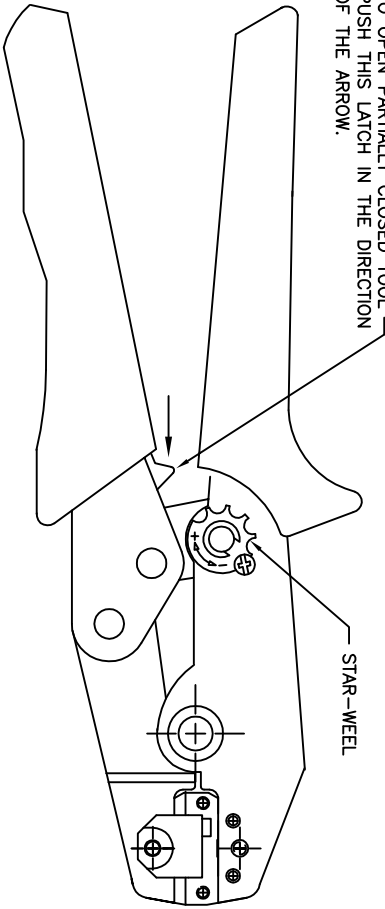

STAR-WHEEL

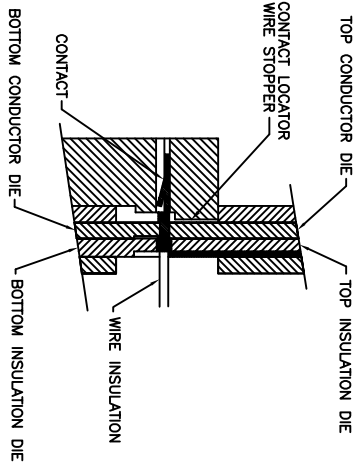

SECTION THROUGH DIE NEST
WITH CONTACT IN POSITION

NOTES:

- | WIRE AWG | CRIMP STRENGTH |
|----------|----------------|
| 24 AWG | 5 LBS |
| 26 AWG | 3 LBS |
| 28 AWG | 2 LBS |
- 1- THIS HAND TOOL IS DESIGNED FOR CRIMPING 24 TO 28 AWG WIRES TO EDAC CONTACT P/N 140-941-290.
 - 2- RISK OF ELECTRIC SHOCK- DO NOT USE THIS ON LIVE WIRE.
 - 3- CRIMPING INSTRUCTIONS:
 - OPEN THE TOOL, PLACE THE CONTACT INTO THE CORRECT DIE NEST.
 - PARTIALLY CLOSE THE TOOL UNTIL THE CONTACT IS HELD IN PLACE. INSERT THE WIRE INTO THE CONTACT.
 - CLOSE THE TOOL UNTIL THE RATCHET RELEASES. REMOVE THE CRIMPED CONTACT.
 - 4- ADJUSTMENT OF CRIMP FORCE (WHEN NECESSARY):
 - LOOSEN THE SCREW
 - ADJUST THE STAR-WHEEL BY TURNING FROM (-) TO(+).
 - CHECK THE PRELOAD AND THE CRIMP FORCE.
- TOOL PART NUMBER: 140-280-201

140 SERIES HAND CRIMP TOOL INSTRUCTIONS

EDAC INC
TORONTO, ONTARIO
CANADA
YOUR CONNECTION TO QUALITY & SERVICE

THESE DRAWINGS AND SPECIFICATIONS ARE THE PROPERTY OF EDAC INC. AND SHALL NOT BE REPRODUCED, OR COPIED OR USED AS THE BASIS FOR THE MANUFACTURE OR SALE OF APPARATUS WITHOUT WRITTEN PERMISSION.

ACAD REFERENCE NO.	140-280-201
DRAWN: K.L.	DATE: OCT.22/2020
CHECKED:	DATE:
SCALE: N.T.S.	SHEET 1 OF 2
DRAWING NUMBER	140-280-201
	ISSUE 1

THIS IS A C.A.D. GENERATED DRAWING
DO NOT MAKE MANUAL REVISIONS TO MASTER.

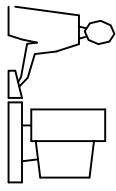

ISSUE NUMBER
ORIGINAL
①

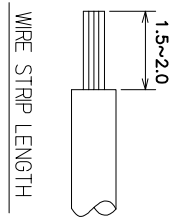
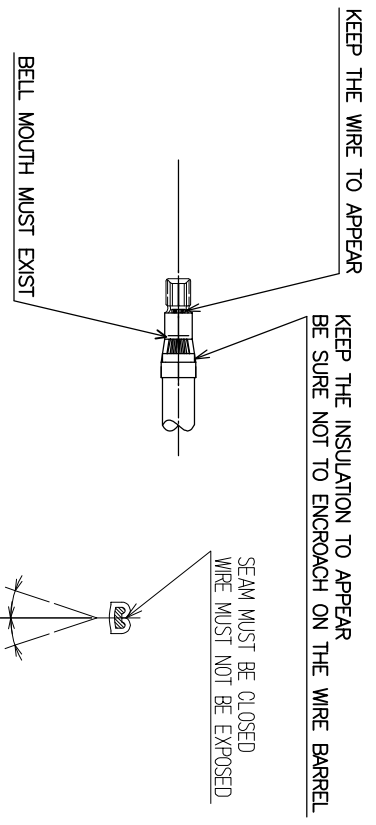
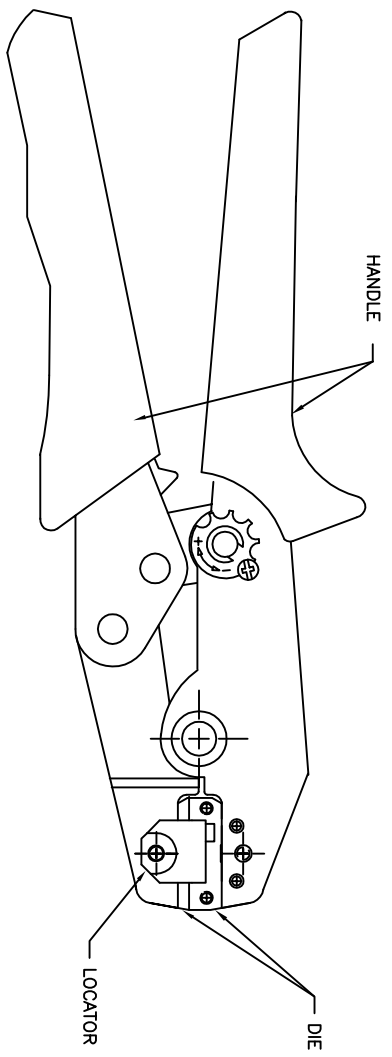

CRIMP ASM*	LOCATOR
140-280-201	140-281-003

* Assembly includes: Handle, Die and Locator. Locator is available for purchase separately.

140 SERIES HAND CRIMP TOOL INSTRUCTIONS

<p>EDAC INC TORONTO, ONTARIO CANADA</p> <p>YOUR CONNECTION TO QUALITY & SERVICE</p>		<p>THESE DRAWINGS AND SPECIFICATIONS ARE THE PROPERTY OF EDAC INC. AND SHALL NOT BE REPRODUCED, OR COPIED OR USED AS THE BASIS FOR THE MANUFACTURE OR SALE OF APPARATUS WITHOUT WRITTEN PERMISSION.</p>	
		ACAD REFERENCE NO.	140-280-201
DRAWN: K.L.		DATE: OCT.22/2020	
CHECKED:		DATE:	
SCALE: N.T.S.	SHEET 2 OF 2		ISSUE 1
DRAWING NUMBER	140-280-201		