

REV	DESCRIPTION	DATE

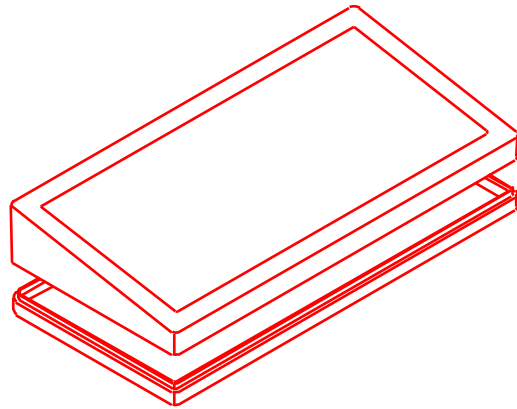

NOTES

MATERIAL (ABS) FLAME RETARDANT UL94 V0 MATERIAL WITH BRASS INSERTS IN CORNER POSTS,
(STYRENE) IS NON-FLAME RETARDANT WITHOUT BRASS INSERTS,

PARTS (ABS) VERSION MACHINE SCREWS M3-0.5 x 10mm,
REPLACEMENT PN 1591MS100 (100 / BAG), (STYRENE)
VERSION SELF TAPPING #4 x 0.5",
REPLACEMENT PN 1591TS100 (100 / BAG),

COLORS (ABS) BLACK, & GRAY, (STYRENE) GRAY ONLY,

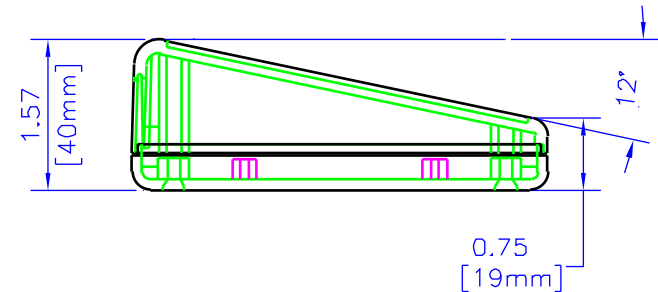
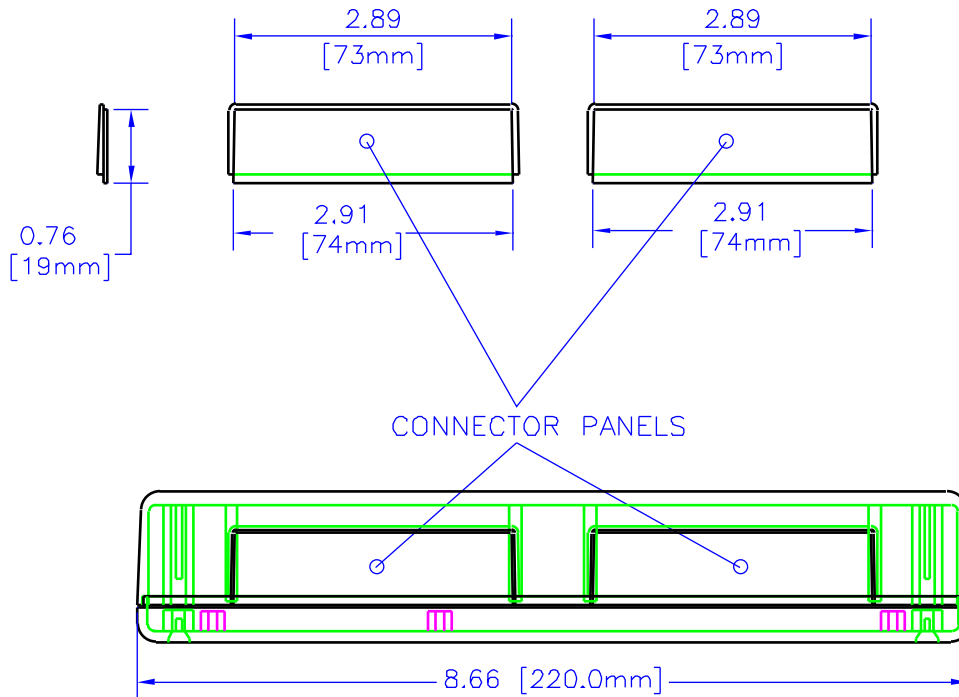

ASSEMBLED

UNLESS OTHERWISE SPECIFIED
DIMENSIONS ARE IN INCHES

X +/- .1
XX +/- .02
XXX +/- .015
CUTS +/- .005
ANGLES +/- 5 DEG

NOTICE
HAMMOND CLAIMS PROPRIETARY RIGHTS TO THE MATERIALS ON THIS DRAWING. IT IS INTENDED TO BE USED AS A REFERENCE FOR ENGINEERING INFORMATION ONLY. THIS INFORMATION MAY NOT BE USED TO MANUFACTURE, PRODUCT WITHOUT WRITTEN PERMISSION FROM HAMMOND MANUFACTURING.



**HAMMOND
MANUFACTURING**

WEB: WWW.HAMMONDMFG.COM

TITLE HAMMOND 1599 SERIES
SLOPED CONSOLE

DRAWN BY MJM DATE 07/06/01

SCALE PAGE 1 OF 3

PART NUMBER
1599HTS

NOTES

DRAFT ANGLES ARE APPROX. 1.1 DEG.

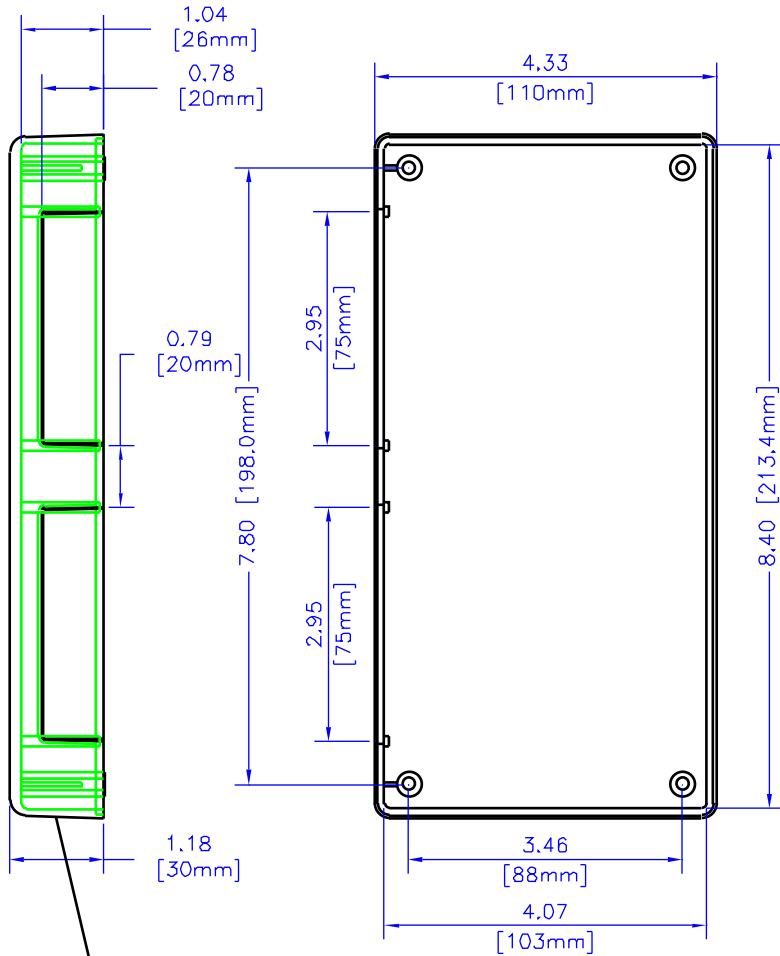
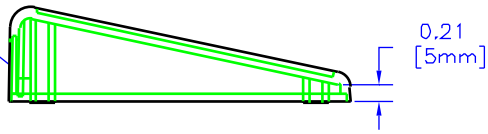

SOME INTERNAL DETAIL IS NOT SHOWN IN THIS END VIEW

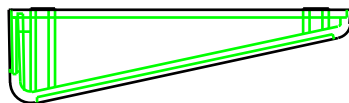

INTERNAL DETAIL IS NOT SHOWN IN THIS END VIEW

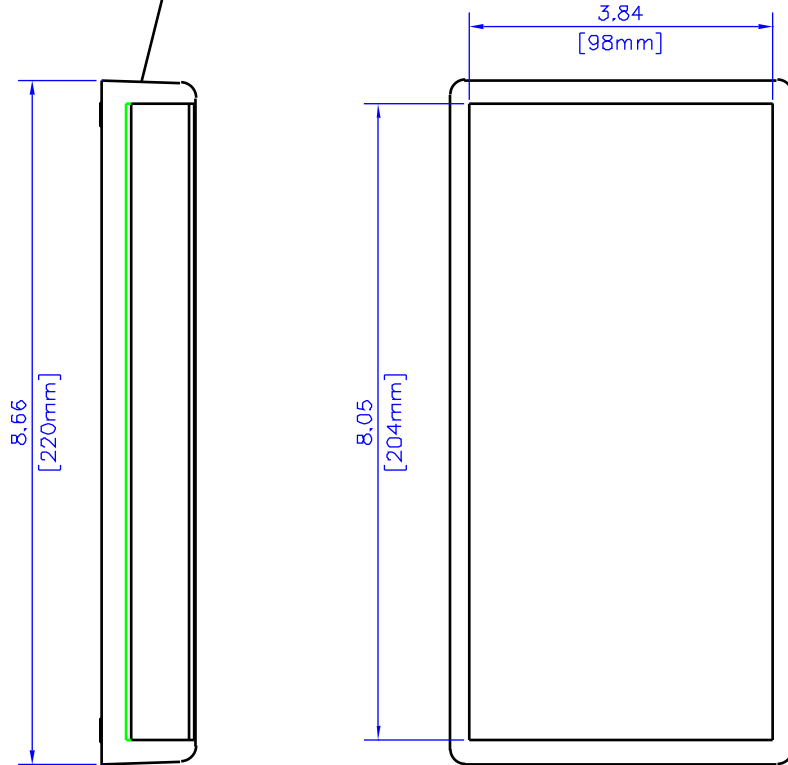

INTERNAL DETAIL IS NOT SHOWN IN THIS VIEW. FACE IS SHOWN FLAT (NOT ANGLED)

BOX

UNLESS OTHERWISE SPECIFIED DIMENSIONS ARE IN INCHES	
K	+/- .1
XX	+/- .02
XXX	+/- .015
DITS	+/- .005
ANGLES	+/- 1/2 DEG.
NOTICE	
RESERVED LEGAL PROPRIETARY RIGHTS TO THE MATERIAL IN THIS DRAWING. IT IS INTENDED TO BE USED AS A REFERENCE FOR ENGINEERING INFORMATION ONLY. THIS INFORMATION MAY NOT BE USED TO MANUFACTURE PRODUCT WITHOUT WRITTEN PERMISSION FROM HAMMOND MANUFACTURING.	



**HAMMOND
MANUFACTURING**

WEB: WWW.HAMMONDMFG.COM

TITLE		HAMMOND 1599 SERIES SLOPED CONSOLE	
DRAWN BY	MJM	DATE	07/06/01
SCALE		PAGE	2 OF 3
PART NUMBER	1599HTS		

NOTES

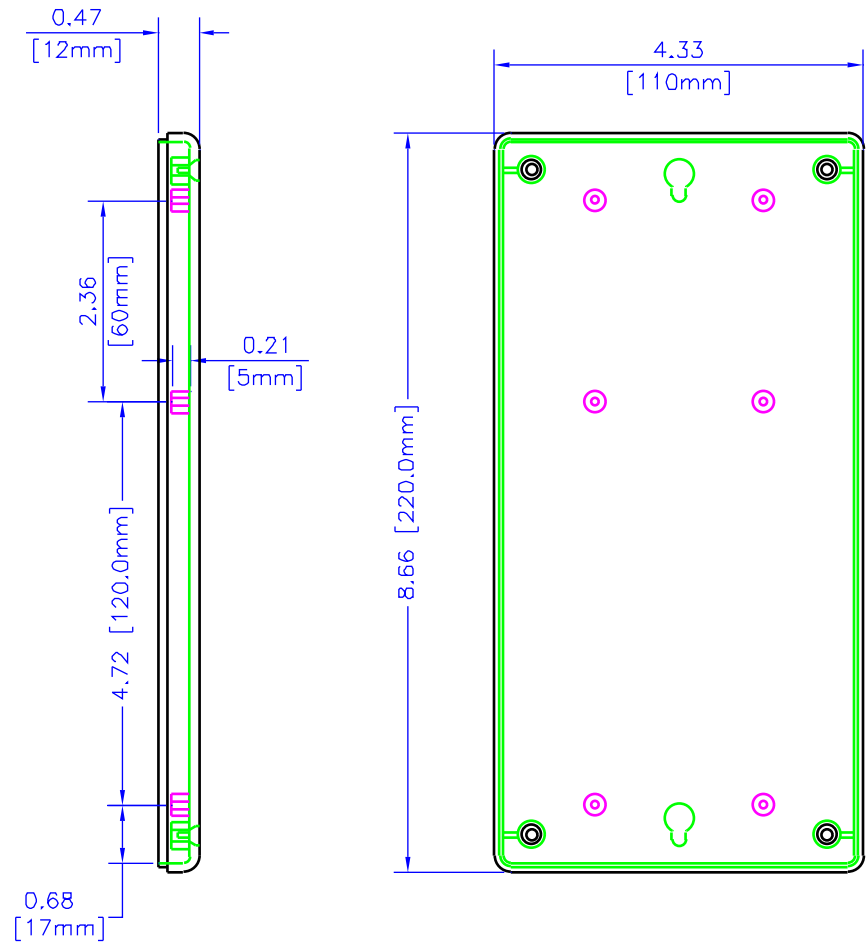
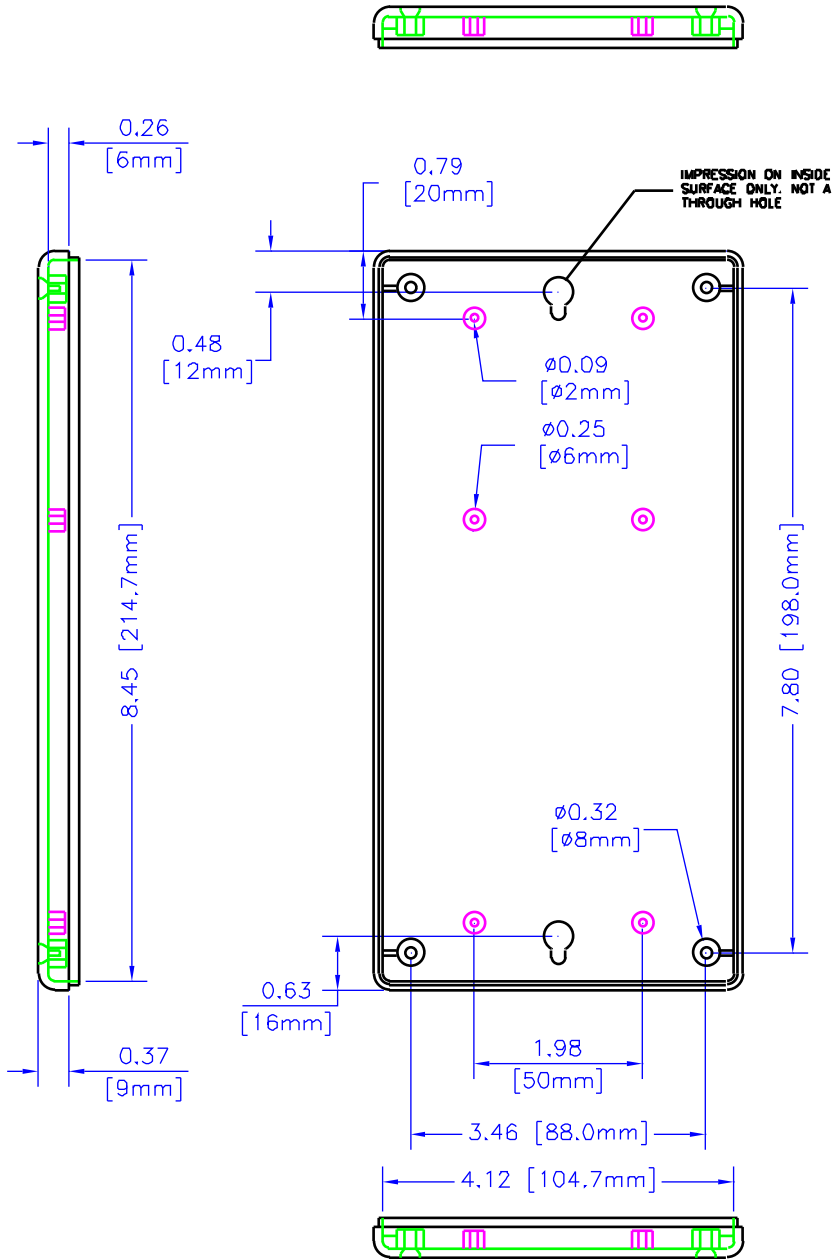

LID

UNLESS OTHERWISE SPECIFIED
DIMENSIONS ARE IN INCHES
 F ±.1
 MXX ±.02
 CUTS ±.005
 ANGLES ±.5 DEG
 NONE
 HAMMOND MANUFACTURING RESERVES RIGHTS TO
 THE MATERIAL ON THIS DRAWING. IT IS
 INTENDED TO BE USED AS A REFERENCE FOR
 ENGINEERING INFORMATION ONLY. THIS
 INFORMATION MAY NOT BE USED TO
 MANUFACTURE PRODUCT WITHOUT WRITTEN
 PERMISSION FROM HAMMOND MANUFACTURING



**HAMMOND
MANUFACTURING**

WEB: WWW.HAMMONDMFG.COM

TITLE		HAMMOND 1599 SERIES SLOPED CONSOLE	
DRAWN BY	MJM	DATE	07/06/01
SCALE		PAGE	3 OF 3
PART NUMBER		1599HTS	