

**(b)**  
NOTES:

1. RECOMMENDED SOLDER INSTRUCTION SEE SHEET 2
2. IP RATING: IP 67
3. SEALED TO WITHSTAND PRESSURE UP TO 1,45 PSI FOR 30 MINUTES AFTER SOLDERING
4. METAL SHELL: ZINC DIE CAST; min. 50µin NICKEL PLATING over COPPER
5. INSULATORS: PBT GF UL 94 V-0, BLACK
6. O-RING: SILICONE PER ASTM D2000 70 SHORE A
7. SEALING COMPOUND: EPOXY RESIN UL 94 V-0; BLACK
8. CONTACTS: COPPER ALLOY  
PLATING (SEE PART NO):  
□ PLEASE ADD 1 for 30µin HARD GOLD over min. 50µin NICKEL  
□ PLEASE ADD 3 for 8µin HARD GOLD over min. 50µin NICKEL  
SOLDER CUP ACCEPTS CABLE AWG 20
9. HEXLOCKING SCREWS: STAINLESS STEEL
10. RECOMMENDED PANEL CUT-OUT ON SHEET 2
11. RECOMMENDED TORQUE FOR MOUNTING SCREW  
35Ncm (3.1 in.LB) / max.67Ncm (6 in.LB)
12. CONNECTOR IS PART MARKED: **15-00062** □ CONEC ABC

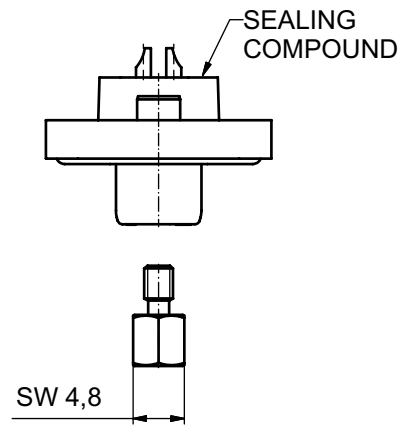
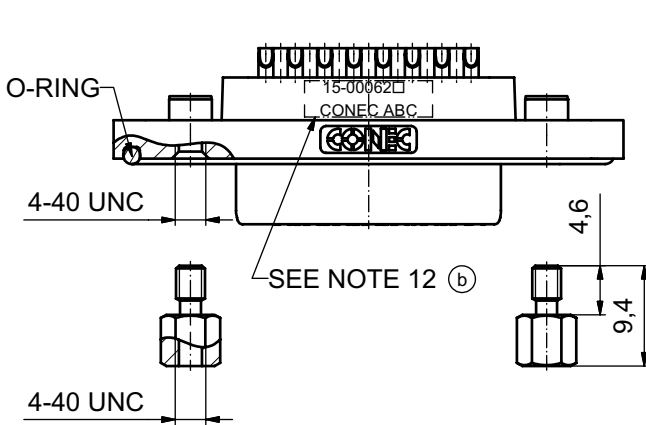
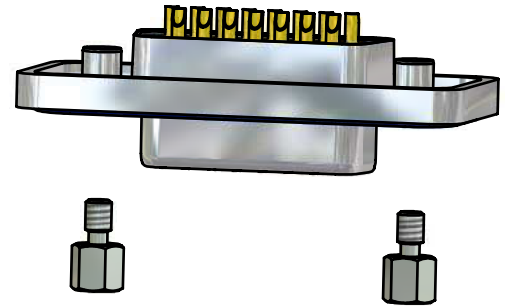
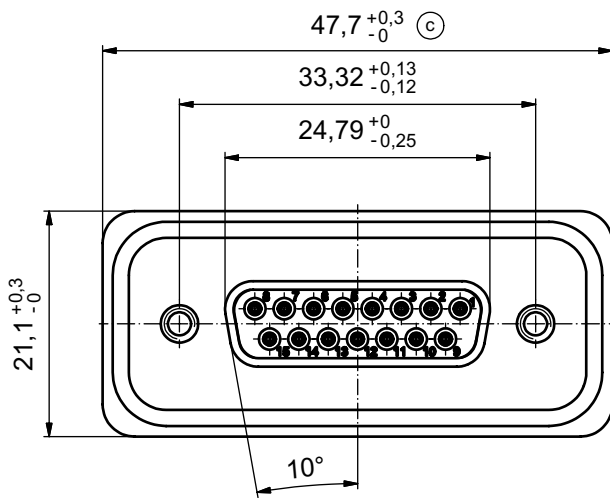
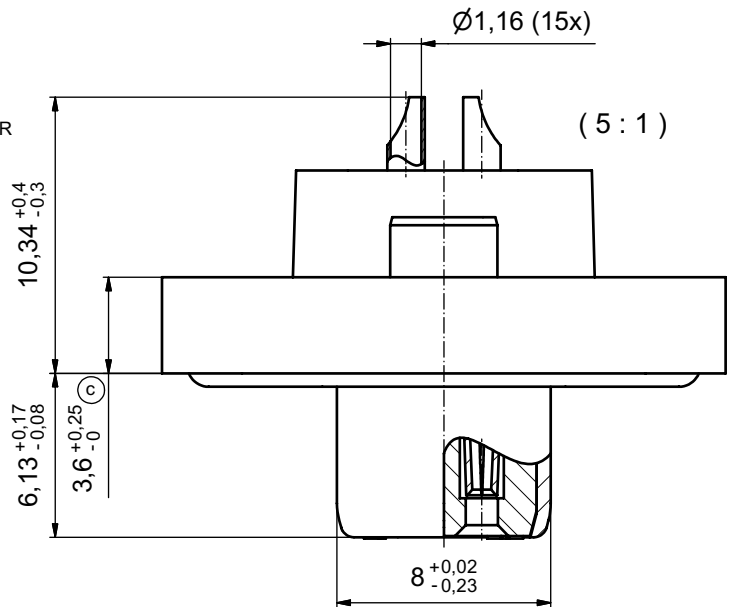

**(c)**  
AT ALL TIMES WATER RESISTANT CONNECTORS NOT IN USE SHOULD BE COVERED WITH A CONEC WATER RESISTANT CAP OR WATER TIGHT HOOD.

Directive 2002/95/EC  
RoHS  
Compliant

APPROVAL # FREIGABE # DEBLOCAGE # AUTORIZACION # APPROVAL	
CUSTOMER APPROVAL DATE:	
NAME:	TITLE:
COMPANY NAME:	
APPROVAL # FREIGABE # DEBLOCAGE # AUTORIZACION # APPROVAL	

THIS DRAWING MAY NOT BE COPIED OR REPRODUCED IN ANY WAY, AND MAY NOT BE PASSED ON TO A THIRD PARTY WITHOUT WRITTEN PERMISSION. OWNERSHIP AND COPYRIGHT OF CONEC GmbH			
DO NOT ALTER CAD DRAWING BY HAND			
3 x c	Ä 3435	30.09.09	HS
3 x b	Ä 3129	26.09.08	Pelker
a	Origin		
rev.	description	date	name

tolerance		scale:	2:1 (5:1)
	dim. in mm	material:	see notes
date	name	title: <b>D-SUB FEMALE</b> 15pos. SOLDER CUP with hexlocking screw	
drawn	08.09.08 Schmidt		
appd.	15.09.08 Fischer		
norm		dwg no:	Inventor 10
			DIN-A3
			sh: 1
		part no:	15-00062 □ (see note 8) (b)



ⓑ

### Solder Instruction

1. Cable should be prepared for soldering. The cable/wires must be pretinned.
2. Insert cable/wire into solder cup.
3. Operate the soldering iron at 350°C, 50 Watt max. and use a pencil tip.
4. Put tip to wire in solder cup.
5. After 1 second bring in solder.
6. Heat for 3 seconds longer. Do not heat contact more than 4 seconds in total.
7. Remove soldering iron.
8. Wait until solder gets rigid again.
9. Do not solder adjacent contacts consecutively, alternate position within the connector to minimize heat build up.

### RECOMMENDED PANEL CUT-OUT

ⓑ

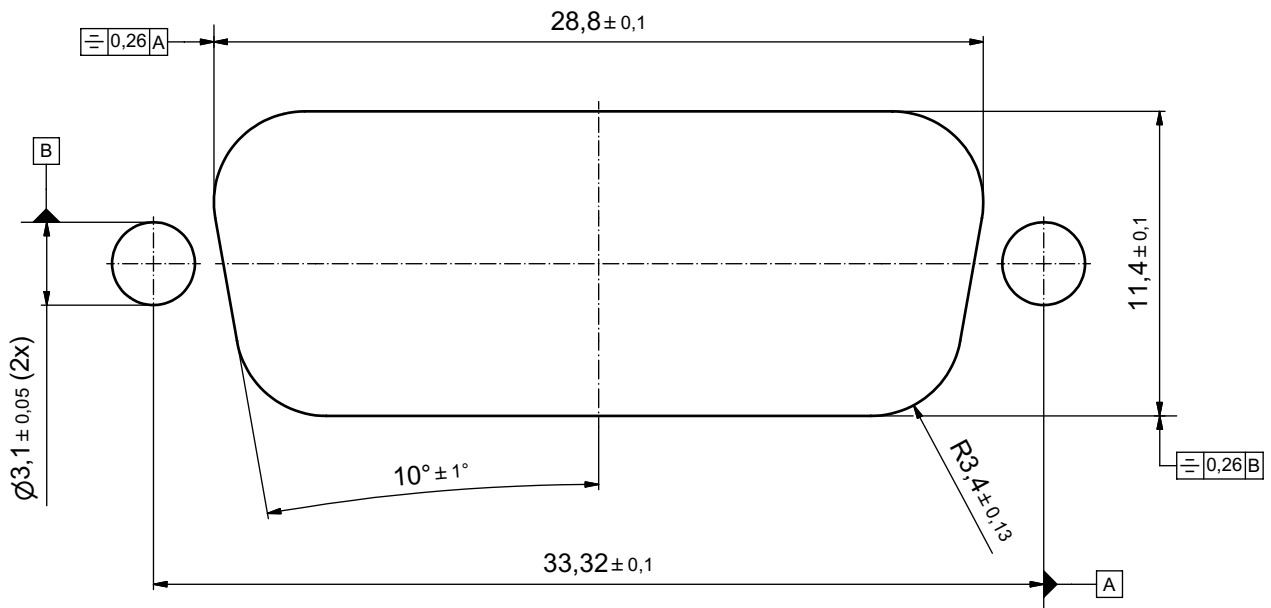

APPROVAL # FREIGABE # DEBLOCAGE # AUTORIZACION # APPROVAL	
CUSTOMER APPROVAL DATE:	
NAME:	TITLE:
COMPANY NAME:	
APPROVAL # FREIGABE # DEBLOCAGE # AUTORIZACION # APPROVAL	

THIS DRAWING MAY NOT BE COPIED OR REPRODUCED IN ANY WAY, AND MAY NOT BE PASSED ON TO A THIRD PARTY WITHOUT WRITTEN PERMISSION. OWNERSHIP AND COPYRIGHT OF CONEC GmbH			
DO NOT ALTER CAD DRAWING BY HAND			
2 x b	A 3129	26.09.08	Petker
a	Origin		
rev.	description	date	name

tolerance		dim. in mm
date	name	
drawn	08.09.08	Schmidt
appd.	15.09.08	Fischer
norm		
d-old		

scale: 5:1	
material: see sheet 1	
title: PANEL CUT-OUT D-SUB FEMALE 15pos. SOLDER CUP with hexlocking screw	
dwg no: Inventor 10	DIN-A3
15K1A262	
sh: 2	
part no: see sheet 1	

