

| | | | | | | | |
|-----|-------------------------|------|------|-----|-------------------------|------|------|
| No. | Changes and/or Note No. | Date | Sign | No. | Changes and/or Note No. | Date | Sign |
| | | | | | | | |

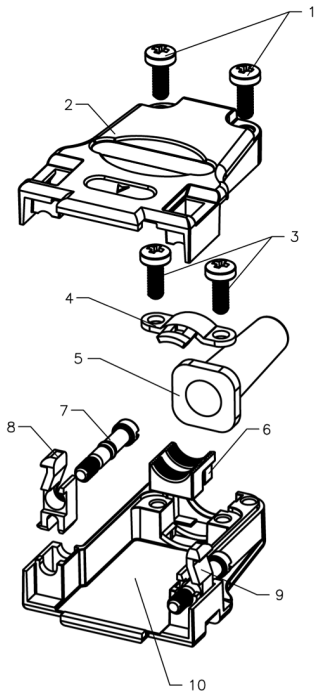

| Part Number | Description | Pack | ITEM | PART NAME | Q'ty | NOTES |
|--------------|-------------|------|------|---------------|------|------------|
| 7960-0205-01 | DTZF09-RG-K | Kit | 1 | SCREW M2.5*8 | 2 | M2.5 |
| | | | 2 | METAL HOOD-1 | 1 | Zinc alloy |
| | | | 3 | SCREW M2.5*6 | 2 | M2.5 |
| | | | 4 | WASHER | 1 | |
| 7961-0205-01 | DTZF09-RG | Bulk | 5 | SR | 1 | |
| | | | 6 | STRAIN RELIEF | 1 | |
| | | | 7 | BOLT | 2 | UNC 4-40 |
| | | | 8 | LATCH-1 | 1 | |
| | | | 9 | LATCH-2 | 1 | |
| | | | 10 | METAL HOOD-2 | 1 | Zinc alloy |

| | | | | | |
|--------------------|--------------|---------------|---------------|--|--|
| DATE 2013-06-13 | DRAWN MRR | SCALE Free | MATERIAL TYPE | GENERAL TOLERANCE .X ±0.60 .X ±0.38 .XX ±0.25 | ANGLE TOLERANCE .X ±5° .X ±3° .XX ±2° |
| | APPROVED | | REPLACES | | |

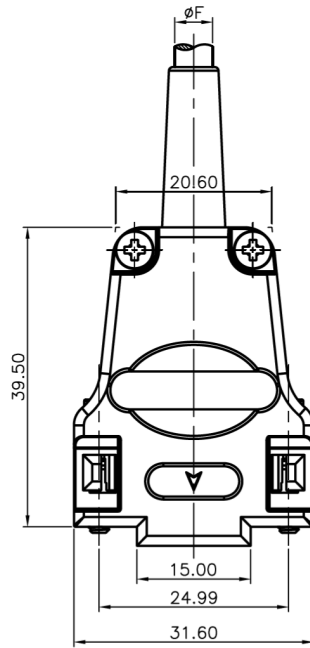
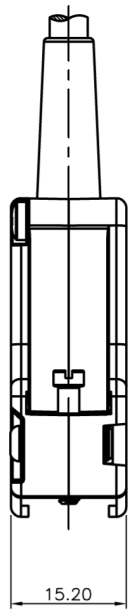

FULL METAL HOOD
DTZF09 - Series
Top Entry

DRAWING No.

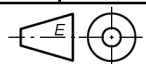

6688-9645