

**Actuator/sensor cable, PUR extension cable**  
**PKW4M-0,6-RSC4.4T/TXL**

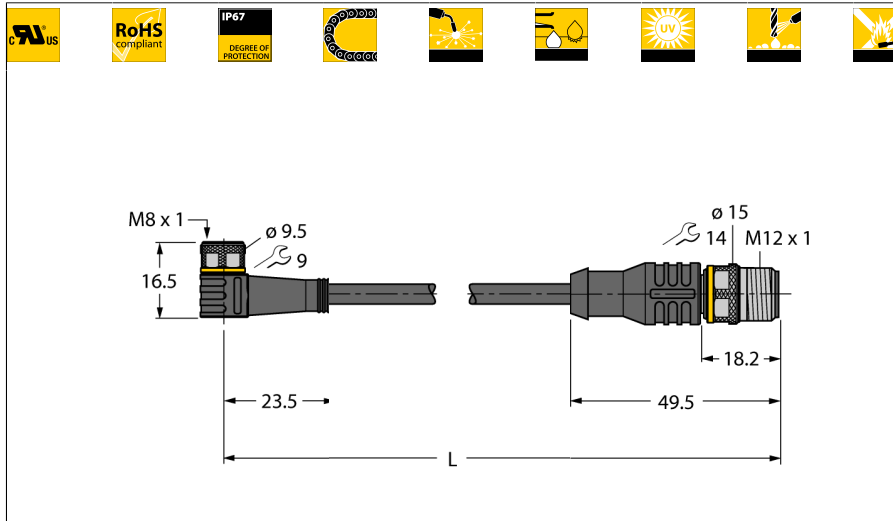

- Female M8, angled, 4-pin
- Male M12, straight, 4-pin
- Sheath material: PUR
- Sheath color: black
- Qualified for drag chain use
- Resistant to weld splatter
- Resistant to chemicals, UV radiation and oils
- Flame retardant
- Free from halogen, silicone, PVC and LABS
- Particularly resistant to abrasion
- Approval: cULus
- RoHS conform
- Protection class IP67
- Cable length: 0.6 m

**Type designation** PKW4M-0,6-RSC4.4T/TXL  
**Ident no.** 6626648

**Connector A side**  
 Number of pins 4  
 Contacts Brass, CuZn, Gold-plated  
 Contact carriers Plastic, TPU, Black  
 Grip Plastic, TPU, Black  
 Coupling nut/screw Brass, CuZn, Nickel-plated  
 Seal Plastic, FPM/FKM  
 Protection class IP67, A + B side screwed together  
 Mechanical lifespan > 100 Mating cycles  
 Pollution degree 3  
 Tightening torque 0.5 ... 0.6 Nm  
 (observe max. torque of counter piece!)

**Cable Cross-section**

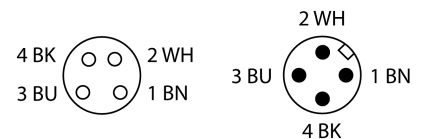
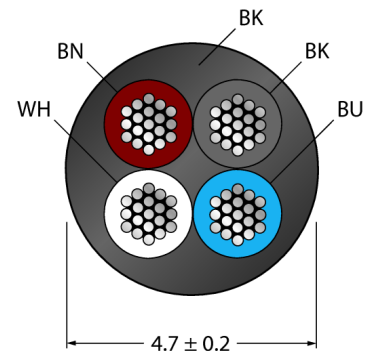

**Connector B side**  
 Number of pins 4 pins  
 Contacts brass, CuZn, Gold-plated  
 Contact carriers Plastic, TPU, Black  
 Grip plastic, TPU, black  
 Coupling nut/screw Brass, CuZn, Nickel-plated  
 Protection class IP67, only in screwed state  
 Mechanical lifespan > 100 Mating cycles  
 Pollution degree 3  
 Tightening torque 0.8 ... 1 Nm  
 (observe max. torque of counter piece!)

**General data**  
 Cable diameter 4.7 ± 0.20mm  
 Cable length 0.6 m  
 Cable quality PUR  
 Cable color Black  
 Core insulation PP  
 Core colors BN, WH, BU, BK  
 Core cross-section 4x0.34mm<sup>2</sup>  
 Arrangement of strands 42x0.1 mm

**General information**

Drawing shows design status including hexagon coupling nut  
 (Start of production CW21/2016).

**Circuit Diagram**

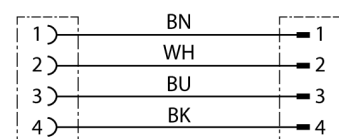

**Electrical features at +20 °C**  
 Current 4 A  
 Rated voltage 30 V  
 Insulation resistance > 30.5 MΩ/km  
 Test voltage 2000 V  
 Forward resistance max. 57 Ω/km

**Actuator/sensor cable, PUR  
extension cable  
PKW4M-0,6-RSC4.4T/TXL**

**TURCK**

Industrial  
Automation

---

**Mechanical and chemical properties**

Max. tensile strength (static)	≤ 50 N/mm <sup>2</sup>
Max. tensile strength (dynamic)	≤ 20 N/mm <sup>2</sup>
Bending cycles	> 5 mil.
Bending radius (stationary laying)	> 5 x Ø
Bending radius (flexible use)	> 10 x Ø
Admissible acceleration	max. 5 m/s <sup>2</sup>
Admissible travel path, horizontal	5 m (at 5 m/s <sup>2</sup> )
Admissible travel path, vertical	2 m (at 5 m/s <sup>2</sup> )
Admissible traversing speed	3.3 m/s
Torsional stress	± 180 °/m
Ambient temperature	
Stationary	-50...+80°C
In motion	-25...+80°C
Drag chain operation	-25...+60°C

**Actuator/sensor cable, PUR  
extension cable  
PKW4M-0,6-RSC4.4T/TXL**

**TURCK**

Industrial  
Automation

**Accessories**

Type code	Ident no.	Description	
Torque-Wrench-Set-AS	6936170	Torque wrench set; handles with adjustable torque 0.4-1.0 Nm, torque wrench for M8 (SW9), fork wrench for M12 (SW 14)	
BLANK-LABEL-FOR-CORDESETS-TEL-TXL	6936206	Label for TEL and TXL cables, length: 18 mm, height: 4 mm, material: polycarbonate (PC), color: white, halogen-free and flame-retardant	