

MKDSP 10/ 3-10,16

Order No.: 1706798

<http://eshop.phoenixcontact.se/phoenix/treeViewClick.do?UID=1706798>

PC terminal block, Nominal current: 57 A, Nom. voltage: 690 V,
Pitch: 10.16 mm, Number of positions: 3, Type of connection: Screw
connection, Assembly: Soldering, Conductor/PCB connection
direction: 0 °, Color: green

Commercial data

EAN	4017918122560
Pack	50
Customs tariff	85369010
Catalog page information	Page 291 (CC-2007)

Product notes

WEEE/RoHS-compliant since:
2003-01-01



Please note that the data given here has been taken from the online catalog. For comprehensive information and data, please refer to the user documentation at <http://www.download.phoenixcontact.com>. The General Terms and Conditions of Use apply to Internet downloads.

Technical data

Dimensions / positions

Pitch	10.16 mm
Dimension a	20.32 mm
Number of positions	3
Pin dimensions	1 x 0,9 mm
Hole diameter	1.5 mm
Screw thread	M4
Tightening torque, min	1.2 Nm
Tightening torque max	1.5 Nm

Technical data

Insulating material group	I
Rated surge voltage (III/3)	8 kV
Rated surge voltage (III/2)	8 kV
Rated surge voltage (II/2)	6 kV
Rated voltage (III/2)	1000 V
Rated voltage (II/2)	1000 V
Connection in acc. with standard	EN-VDE
Nominal current I_N	76 A
Nominal voltage U_N	690 V
Nominal cross section	16 mm ²
Maximum load current	76 A (with 16 mm ² conductor cross section)
Insulating material	PA
Inflammability class acc. to UL 94	V0
Internal cylindrical gage	B6
Stripping length	10 mm

Connection data

Conductor cross section solid min.	0.5 mm ²
Conductor cross section solid max.	16 mm ²
Conductor cross section stranded min.	0.5 mm ²
Conductor cross section stranded max.	16 mm ²
Conductor cross section stranded, with ferrule without plastic sleeve min.	0.5 mm ²
Conductor cross section stranded, with ferrule without plastic sleeve max.	16 mm ²
Conductor cross section stranded, with ferrule with plastic sleeve min.	0.5 mm ²
Conductor cross section stranded, with ferrule with plastic sleeve max.	16 mm ²
Conductor cross section AWG/kcmil min.	20
Conductor cross section AWG/kcmil max	6
2 conductors with same cross section, solid min.	0.5 mm ²
2 conductors with same cross section, solid max.	4 mm ²
2 conductors with same cross section, stranded min.	0.5 mm ²
2 conductors with same cross section, stranded max.	4 mm ²

2 conductors with same cross section, stranded, ferrules without plastic sleeve, min.	0.5 mm ²
2 conductors with same cross section, stranded, ferrules without plastic sleeve, max.	2.5 mm ²
2 conductors with same cross section, stranded, TWIN ferrules with plastic sleeve, min.	0.5 mm ²
2 conductors with same cross section, stranded, TWIN ferrules with plastic sleeve, max.	6 mm ²

Certificates



Certification

CB, CCA, CSA, CUL, GOST, SEV, UL

CSA

Nominal voltage U_N	600 V
Nominal current I_N	57 A
AWG/kcmil	20-6

CUL

Nominal voltage U_N	600 V
Nominal current I_N	60 A
AWG/kcmil	20-6

UL

Nominal voltage U_N	600 V
Nominal current I_N	60 A
AWG/kcmil	20-6

Drawings

Drilling diagram

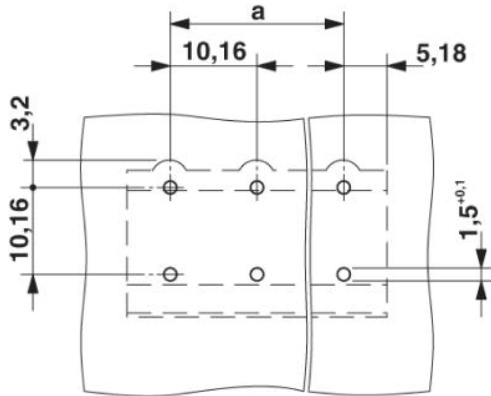

Dimensioned drawing

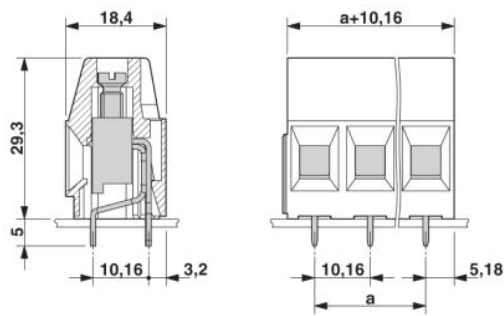

Address

Phoenix Contact AB
Linvägen 2
14144 Huddinge, Sweden
Phone +46 (0)8 - 608 64 00
Fax +46 (0)8 - 608 64 99
<http://www.phoenixcontact.se>

Phoenix Contact Oy
Technical modifications reserved;