

N0031A

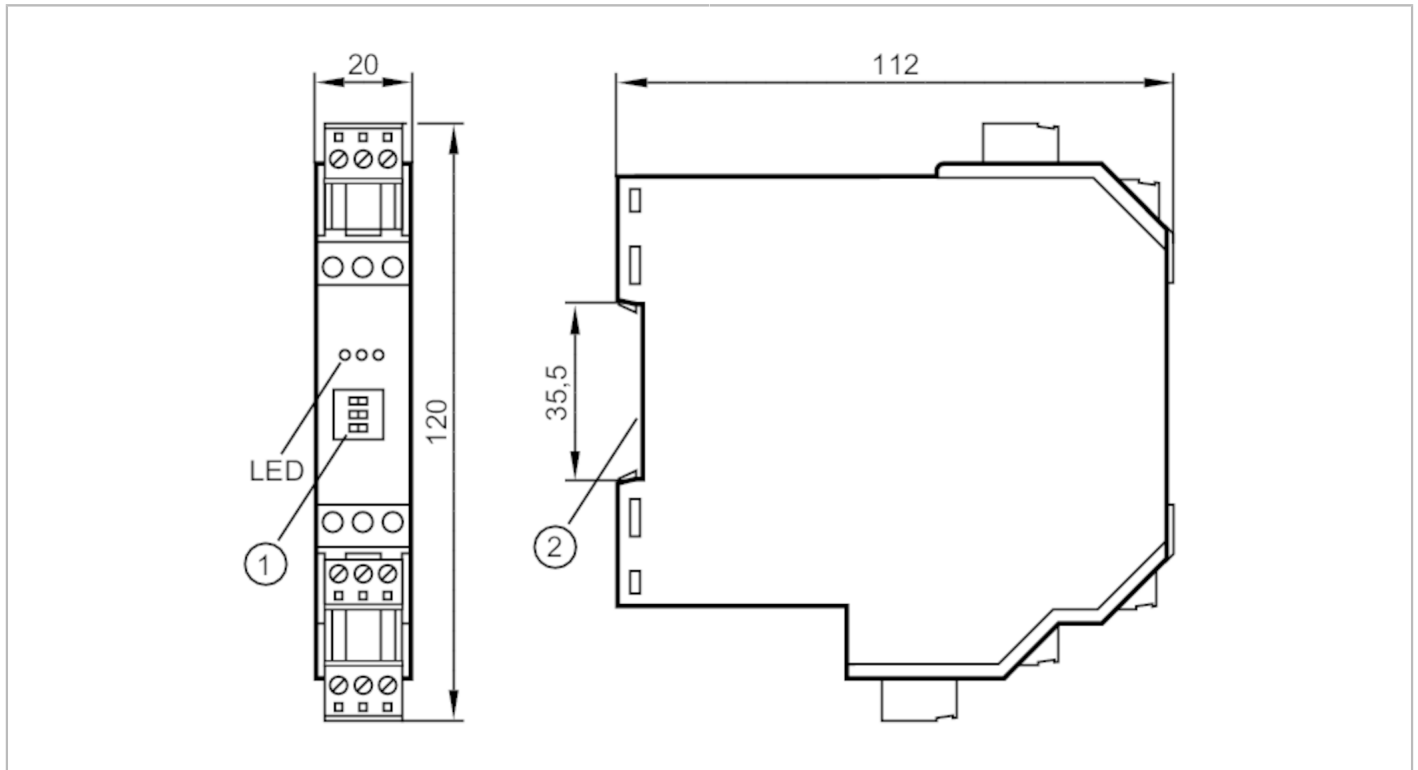

Switching amplifiers for Namur sensors

NV1121/230VAC/RL/1D/1G



Application	
Application	short-circuit monitoring; Wire monitoring
Electrical data	
Operating voltage tolerance [%]	-10...10
Operating voltage [V]	< 230 AC
Max. power consumption [VA]	1
Number of channels	1
Outputs	
Electrical design	relay; (1 changeover contact)
Contact rating	253 V AC / 2 A / cos phi > 0,7 // 40 V DC / 2 A; (ohmic resistance)
Switching frequency AC [Hz]	10
Operating conditions	
Ambient temperature [°C]	-20...60
Protection	IP 20
Tests / approvals	
Approval	PTB 02 ATEX 2035; IECEx PTB 17.0023
ATEX marking	Ex II (1) G [Ex ia Ga] IIC Ex II (1) D [Ex ia Da] IIIC
EMC	EN 50081-2 (1993) EN 61326-1 (2006)
MTTF [years]	458

N0031A



Switching amplifiers for Namur sensors

NV1121/230VAC/RL/1D/1G

Mechanical data		
Weight [g]	193.5	
Switching cycles mechanical	10 million	
Displays / operating elements		
Display	switching status	LED, yellow
	operation	LED, green
	function	LED, red
Remarks		
Remarks	Caution The control monitor must be mounted outside the hazardous area. Free terminals must not be used.	
Pack quantity	1 pcs.	

N0031A



Switching amplifiers for Namur sensors

NV1121/230VAC/RL/1D/1G

Electrical connection

terminals: ...2.5 mm²

Connection

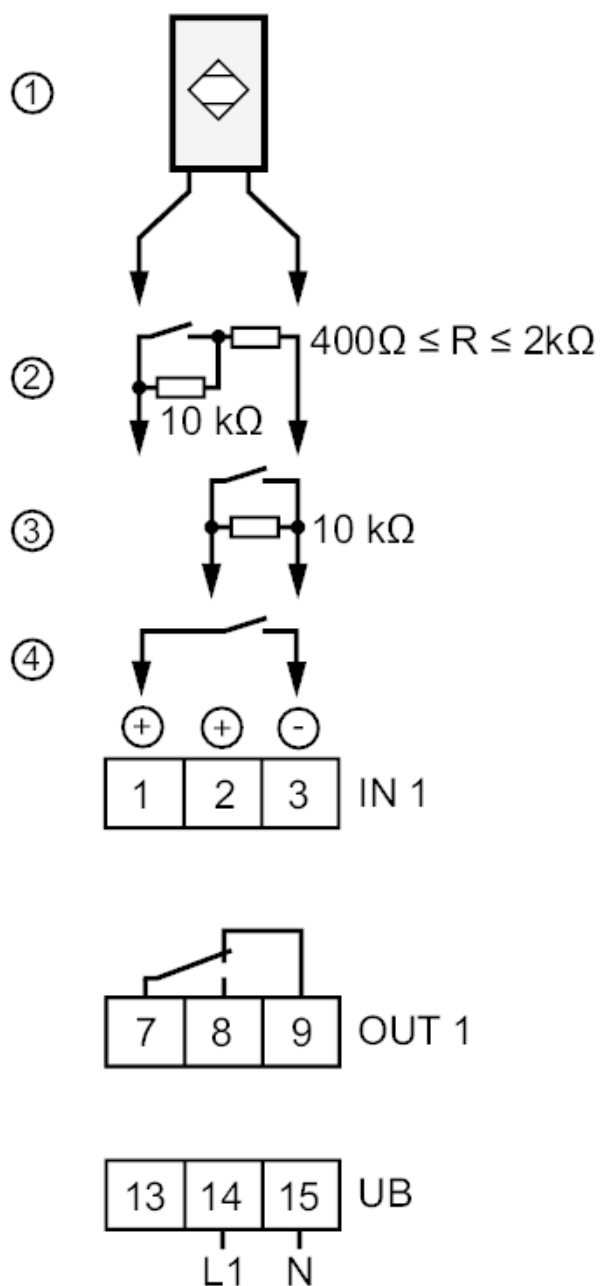

N0031A



Switching amplifiers for Namur sensors

NV1121/230VAC/RL/1D/1G

Other data

Maximum values for control circuit

in protection rating intrinsic safety	[EEx ia] IIC	[EEx ia] IIB	[EEx ib] IIC	[EEx ib] IIB
Voltage [V]	10.6	10.6	10.6	10.6
Current [mA]	19.1	19.1	19.1	19.1
Power [mW]	51	51	51	51
External inductance [mH]	97	390	97	390
External capacitance [μ F]	2.32	16.2	2.32	16.2